

The IceCube Detector

John Kelley
IceCube Director of Operations
UW-Madison

IceCube Summer School, 2026-06-03

with thanks to C. Wendt, N. Kurahashi Neilson, E. Blaufuss, J. van Santen, and D. Glowacki

The "Gen1" IceCube Detector

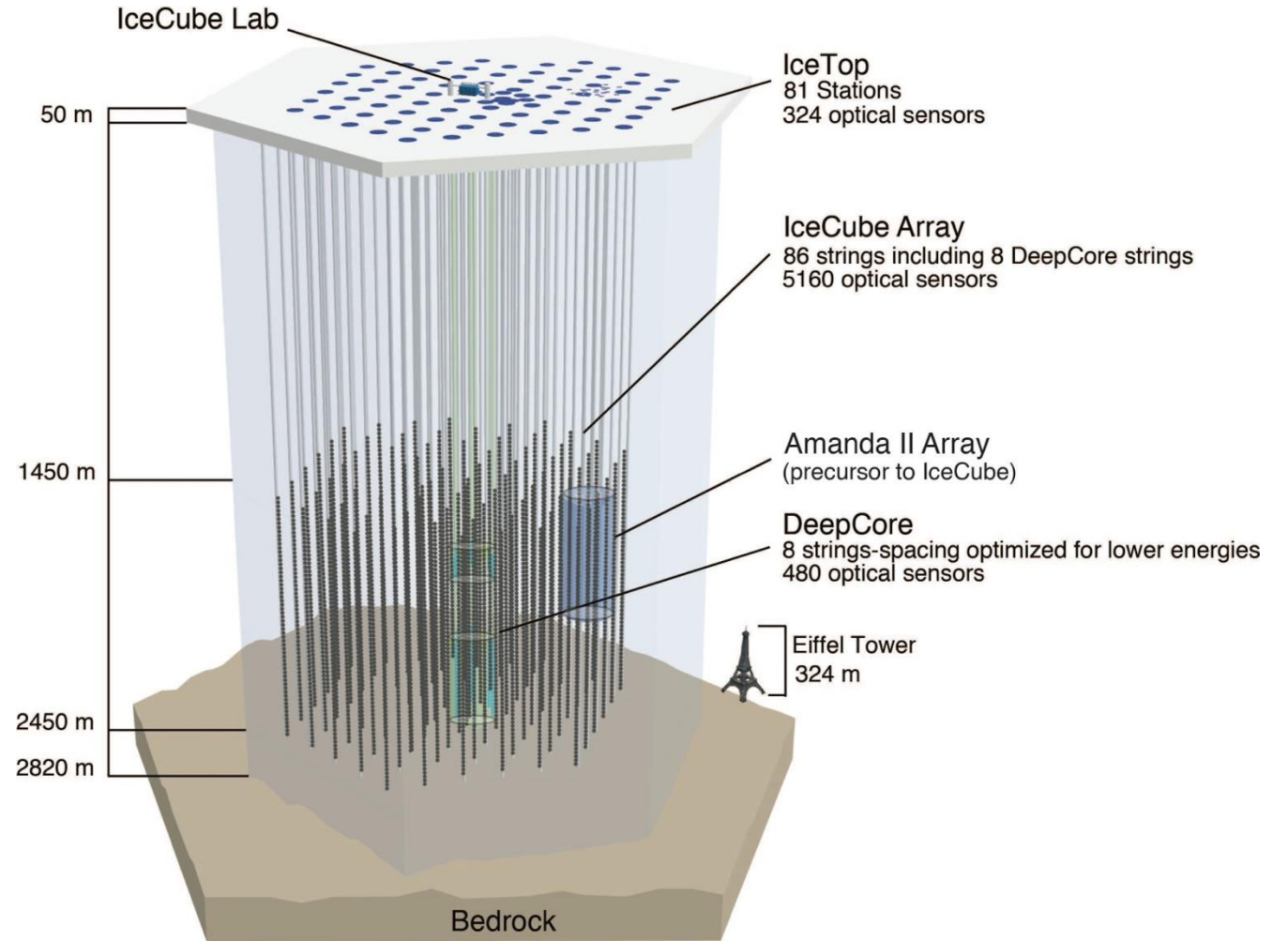
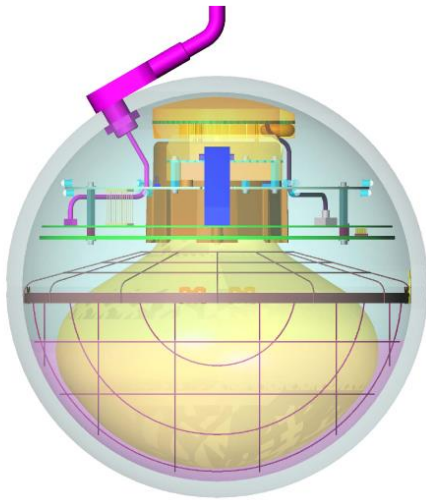
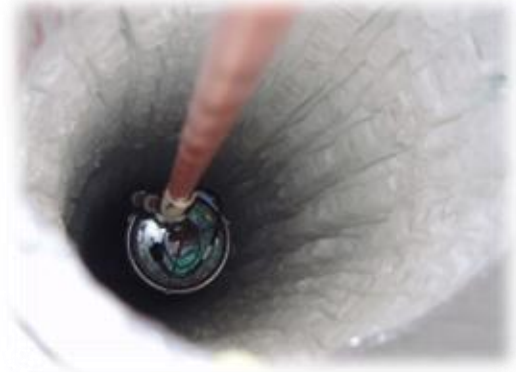

5484 digital optical modules (DOMs)

Detection Principle and Event Types

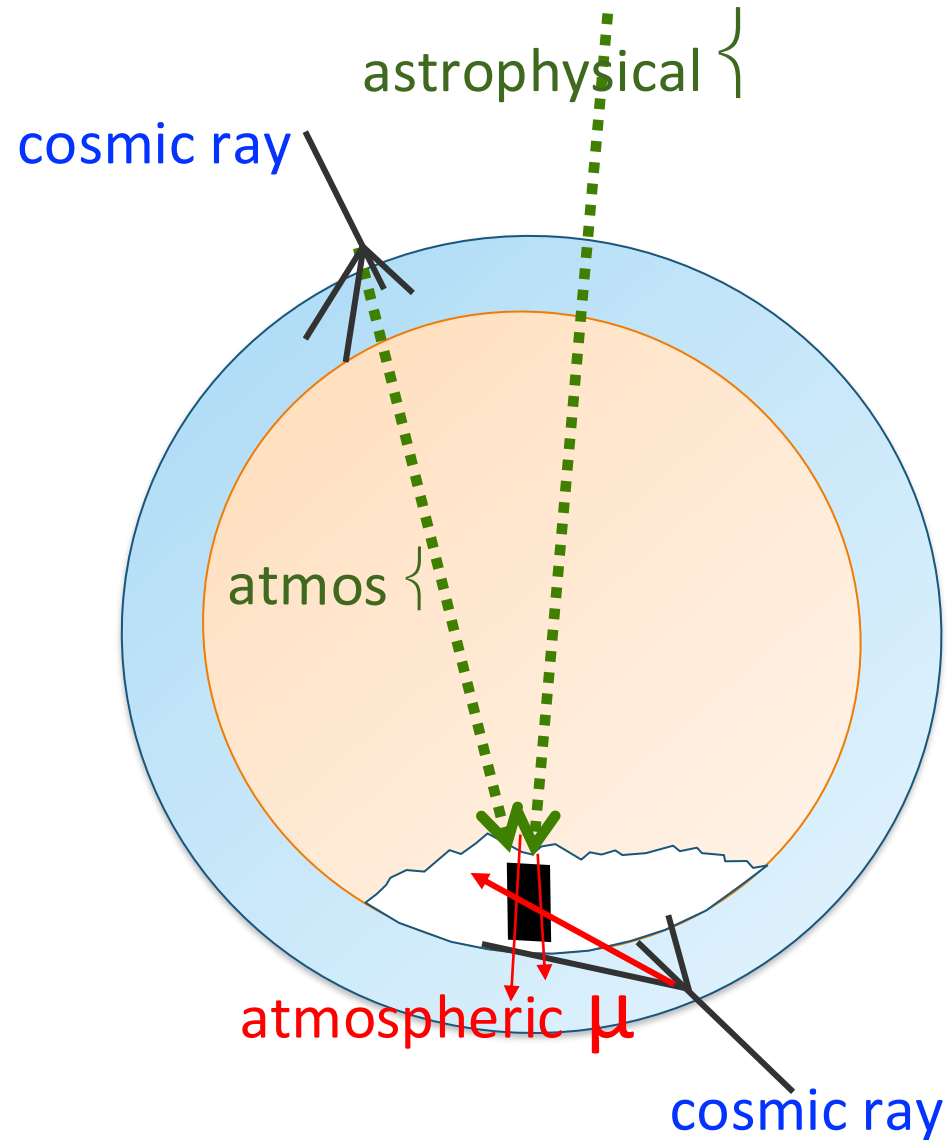

Cosmic-ray muons: ~ 3000 / second
Atmospheric neutrinos: ~ 1 / 5 minutes
Astrophysical neutrinos: ~ 1 / month

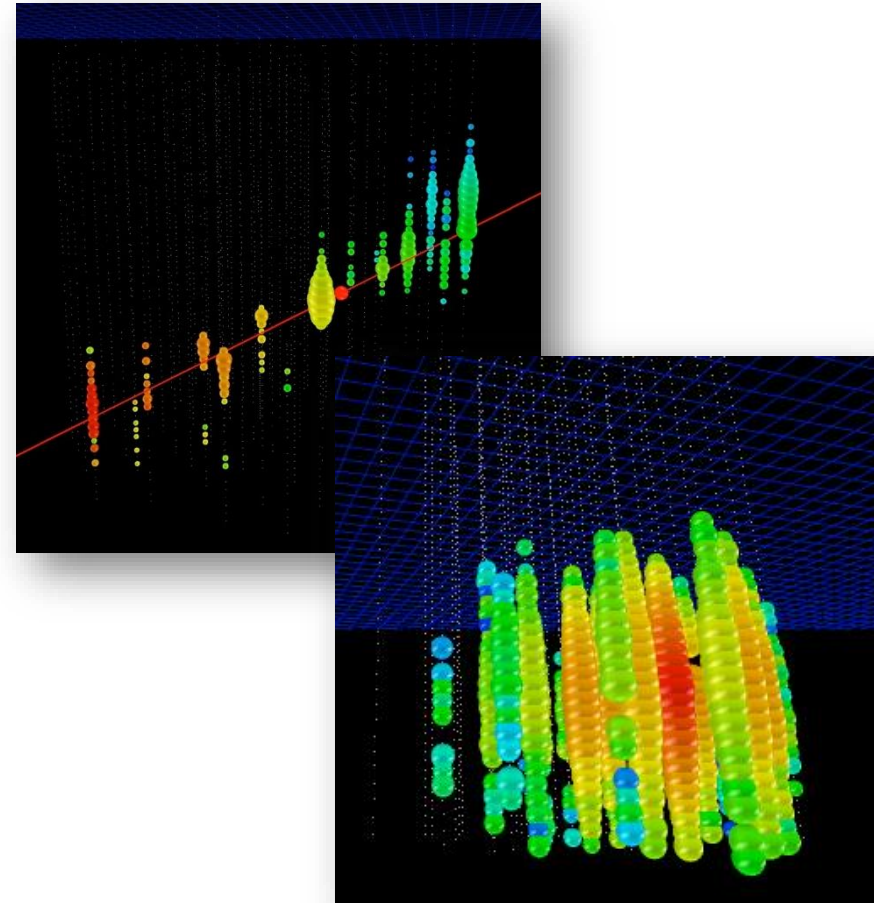

$\nu_\mu \rightarrow \mu$ Detection

- Light is mostly emitted in small bursts along muon track
- Photon arrival times, and how many there are, tell us the direction and the energy of the muon

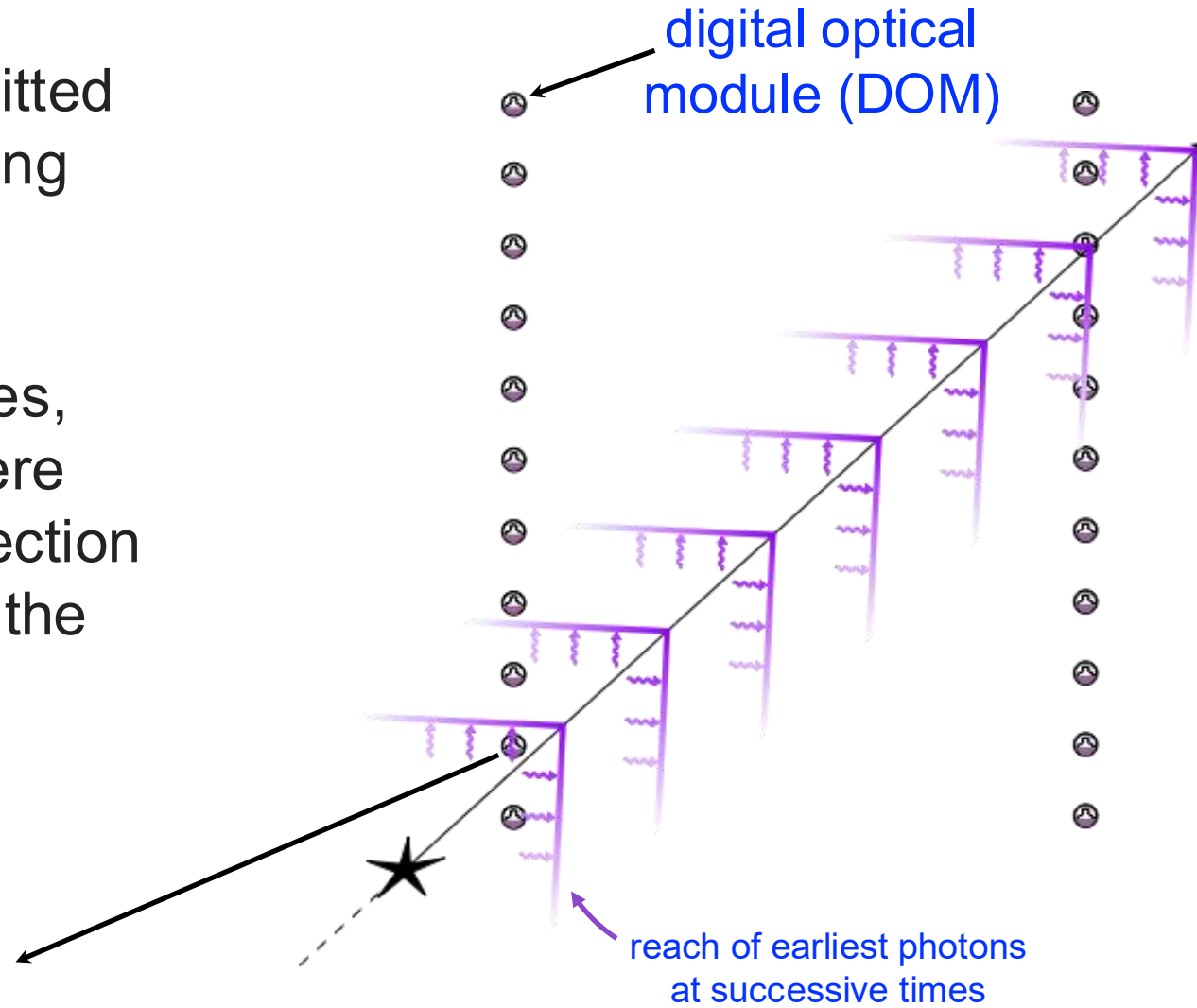
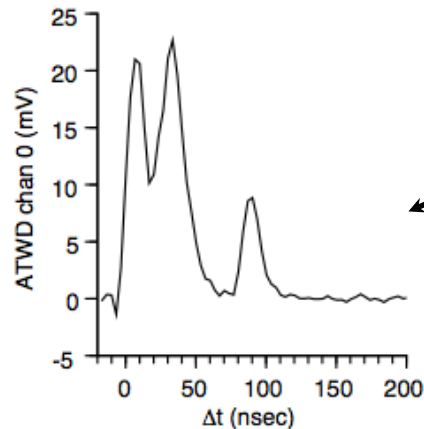

What's in a DOM?

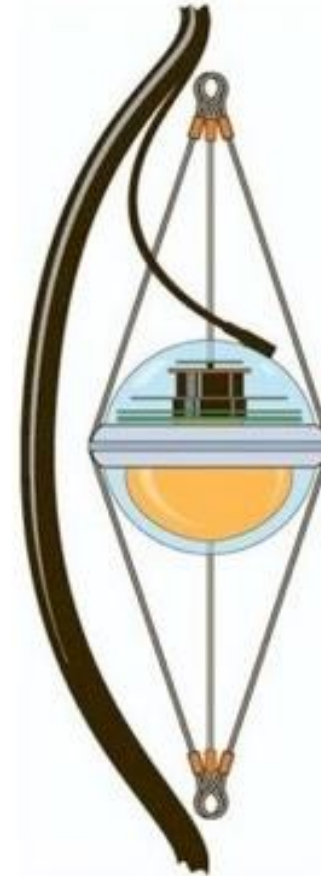
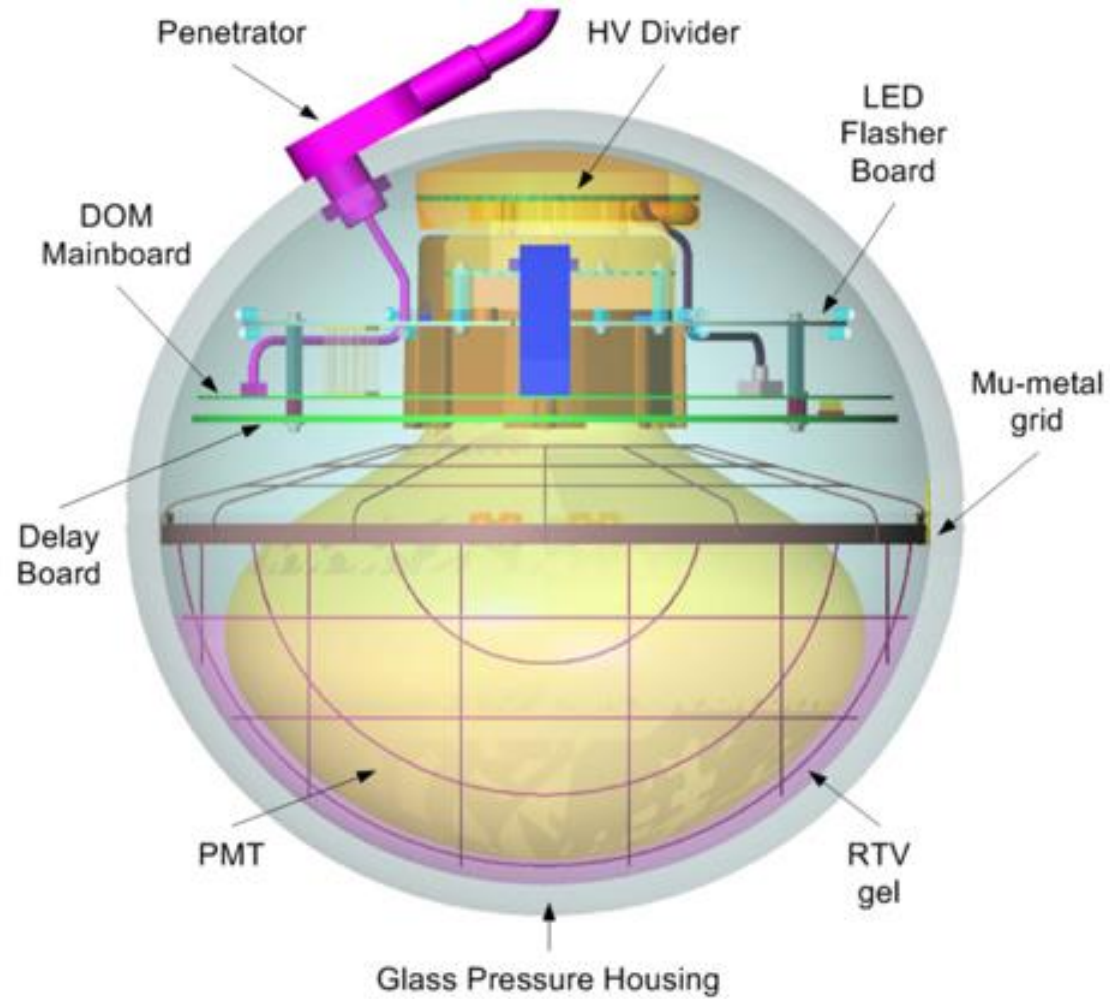

Cable: many twisted pairs, each pair carries power & communications for 2 DOMs

DOM signals resulting from localized light flash

- *Big differences depending on distance from source*

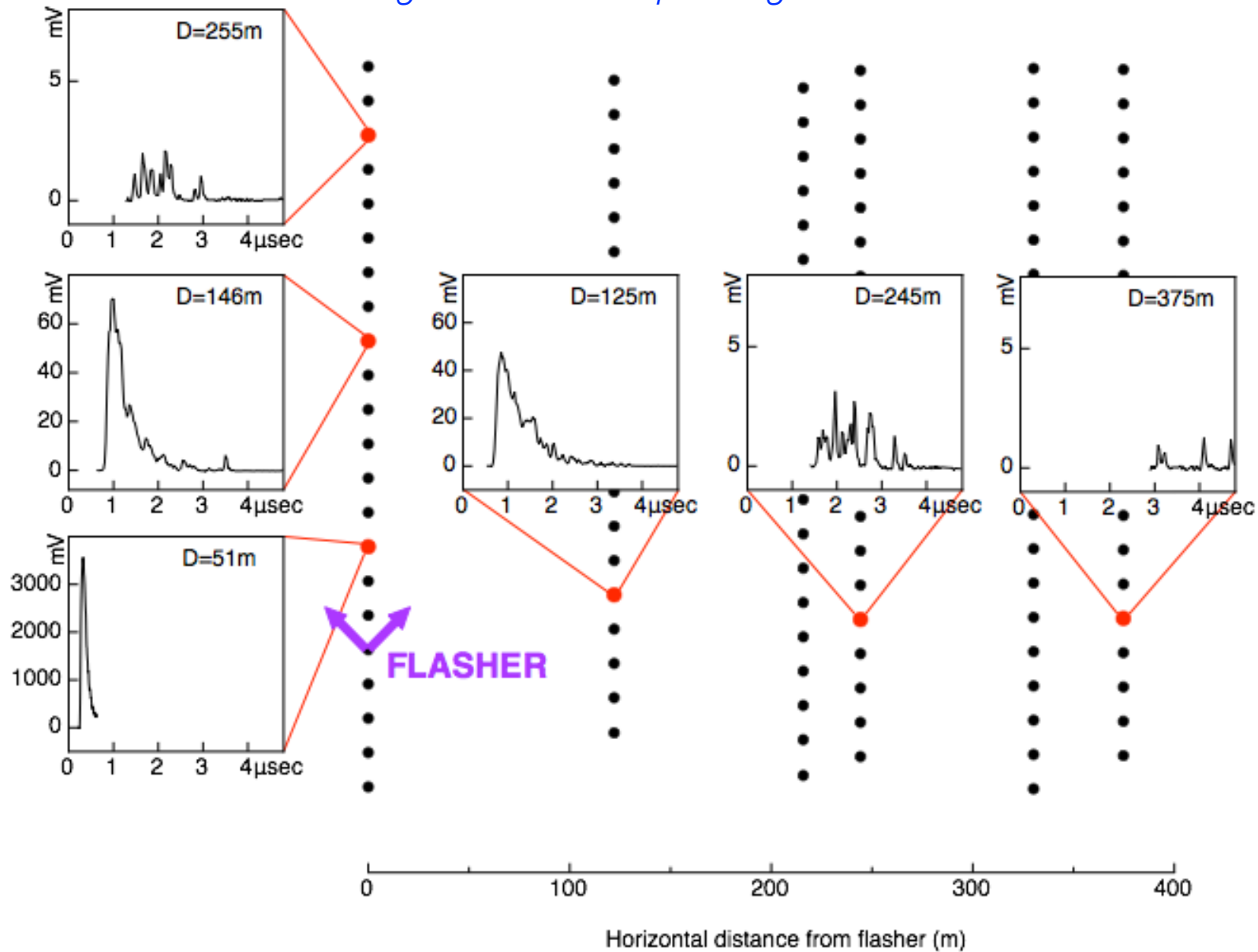

DOM Main Board

Contains waveform digitizers, on-board computer, communications circuits, HV & flasher control, etc.

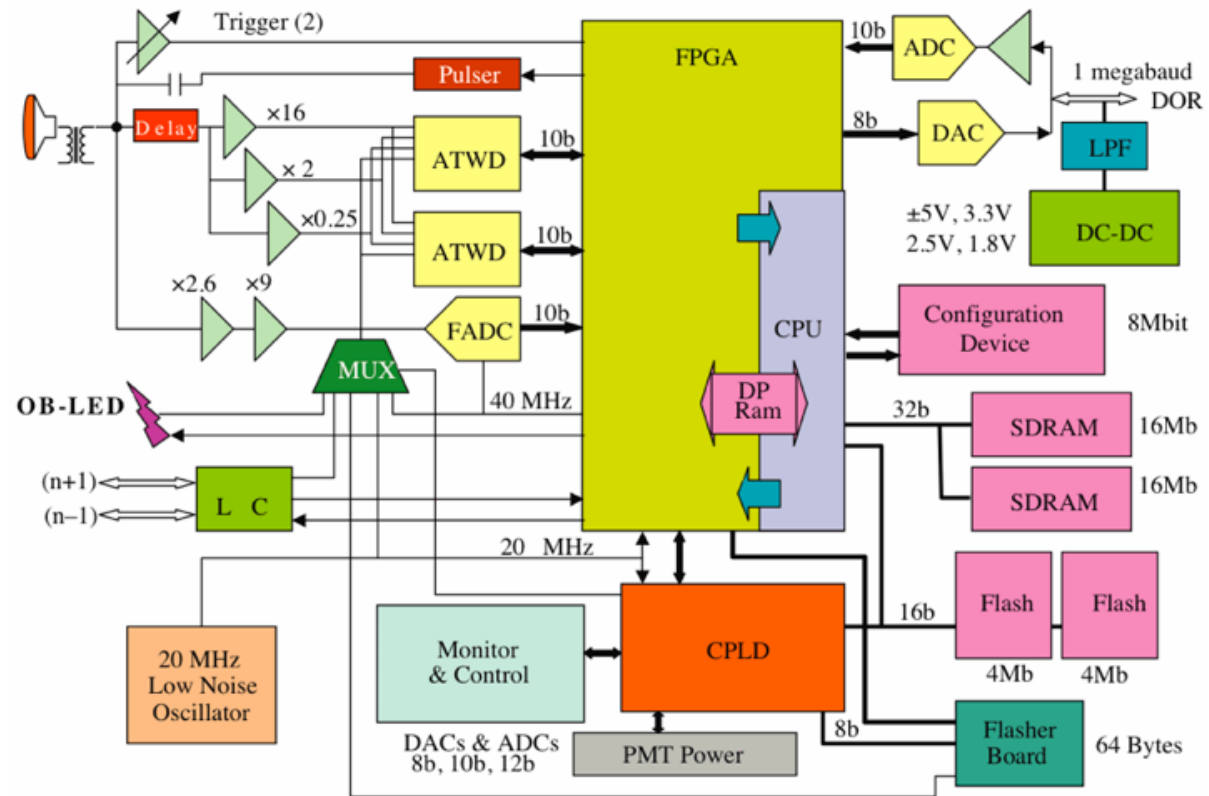

[“The IceCube Data Acquisition Subsystem: Signal Capture, Digitization, and Time-Stamping”](#)

[Nuclear Instruments and Methods in Physics Research A 601 \(2009\) 294–316](#)

<https://docushare.icecube.wisc.edu/dsweb/Get/Document-48249/>

Waveform recorders (digitizers)

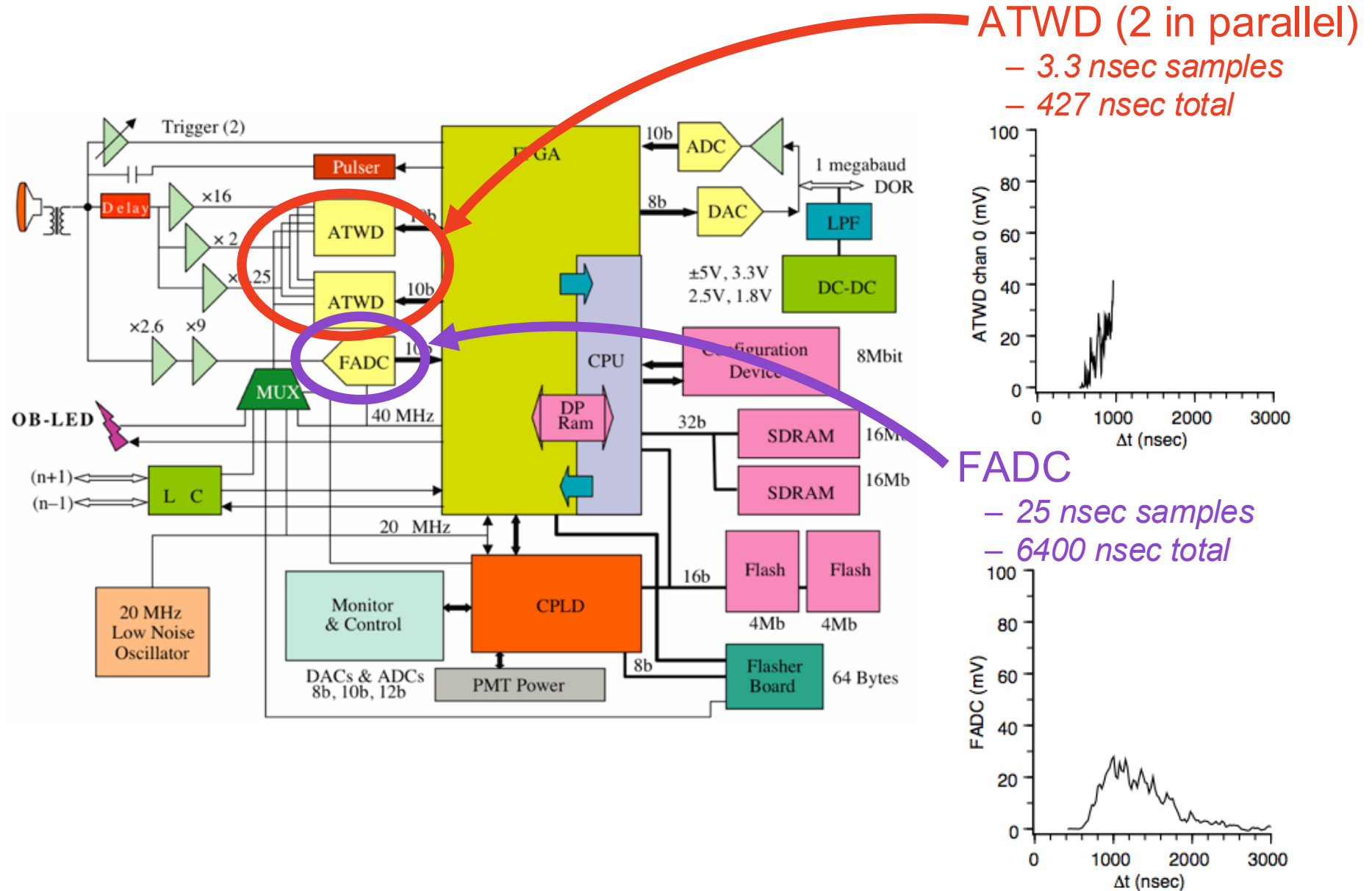

Waveform digitizers "ATWD" Channel 0,1,2

Different gains for small, big pulses

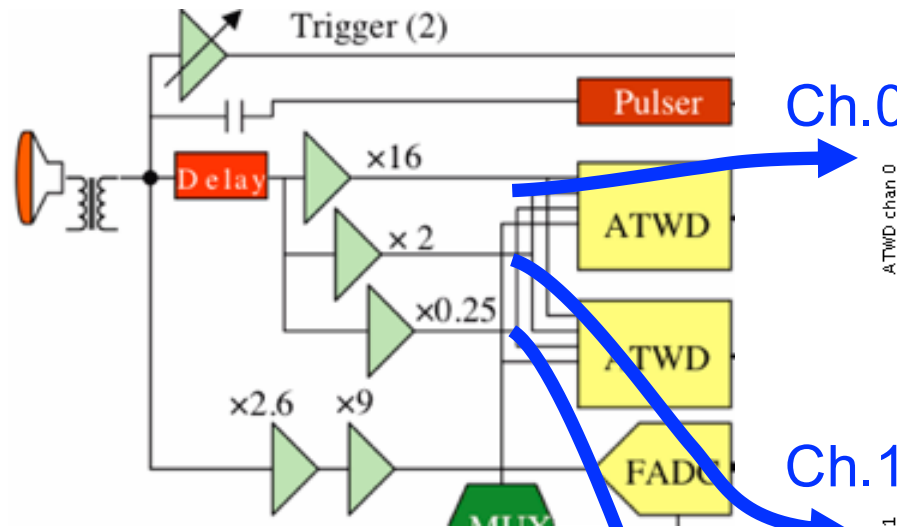

RAW COUNTS
0-1023

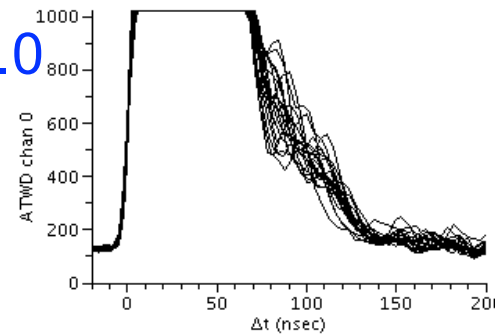

Scaled to millivolts

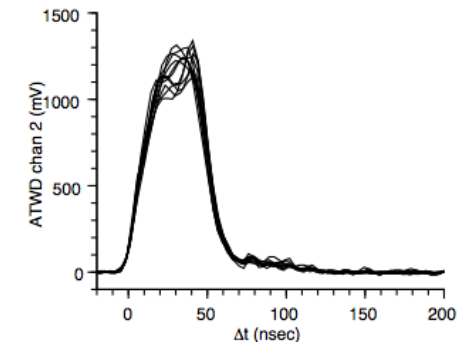
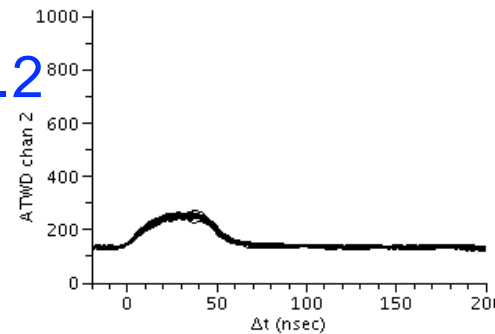
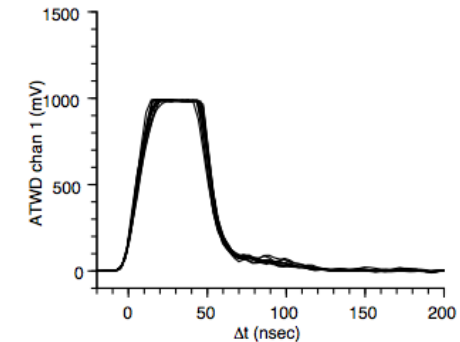
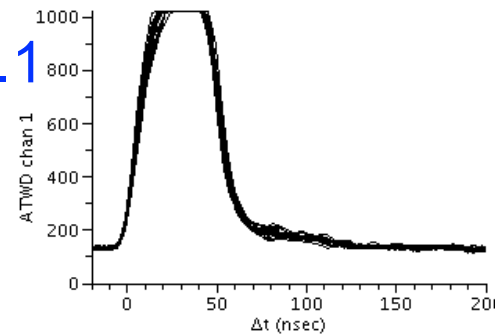
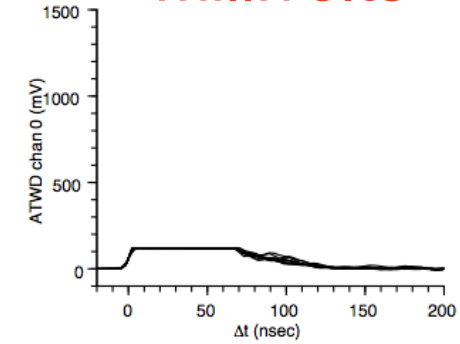

Waveform digitizers “ATWD” Ch. 0,1,2 and “FADC”

Ch.0 good for small waveforms

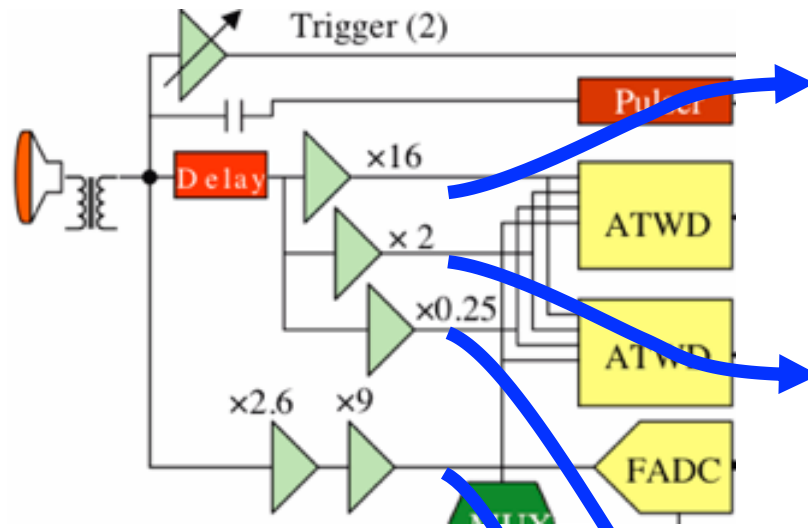

Ch.0

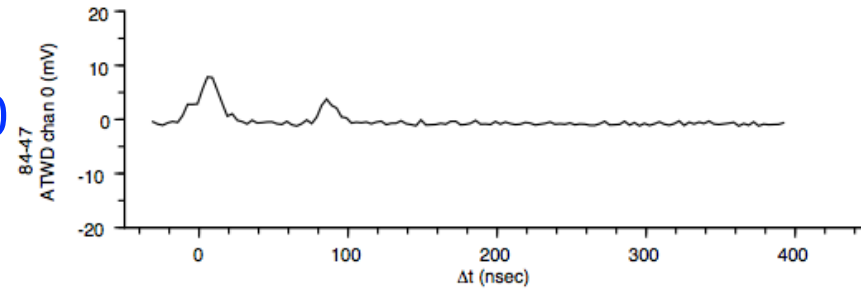

Ch.1

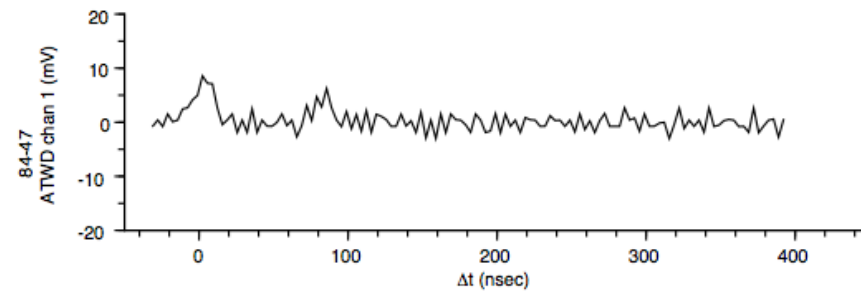

Ch.2

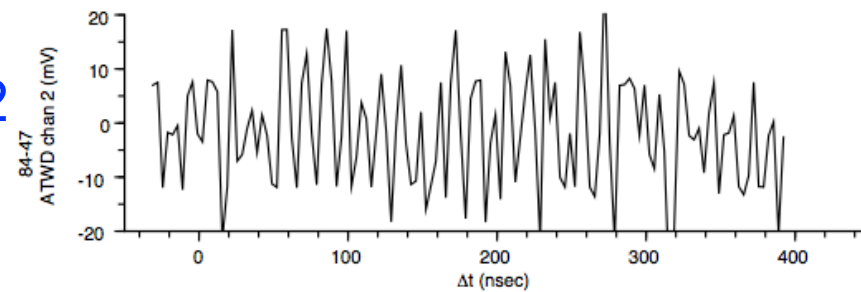

FADC

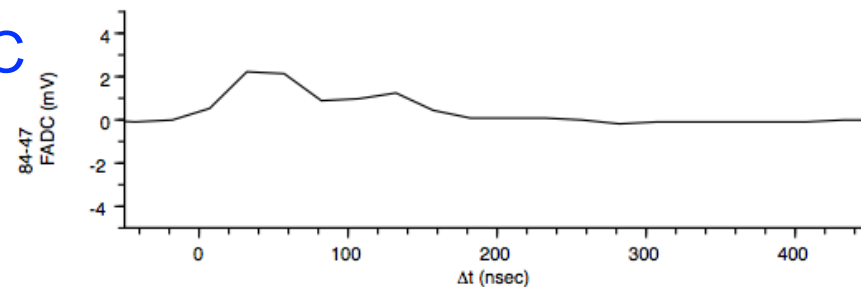

Waveform digitizers “ATWD” Ch. 0,1,2 and “FADC”

Ch.1 good for medium waveforms

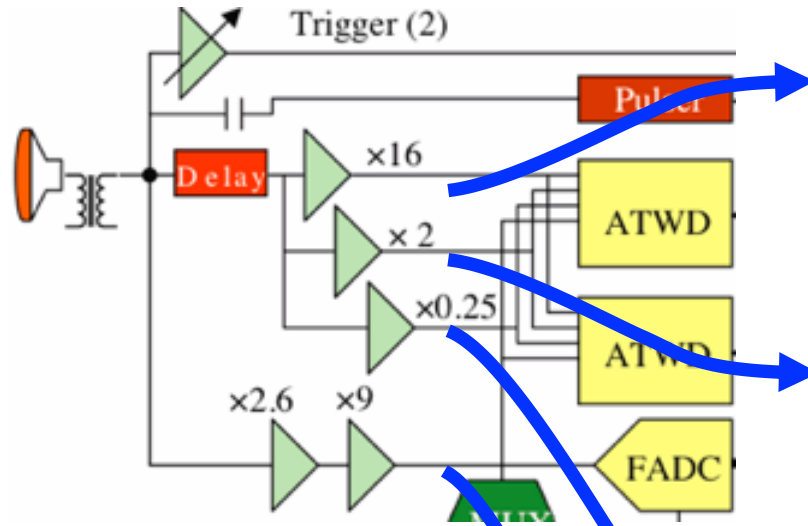

Ch.0

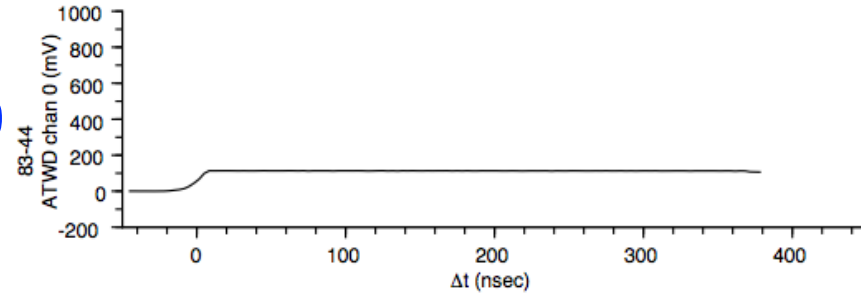

Ch.1

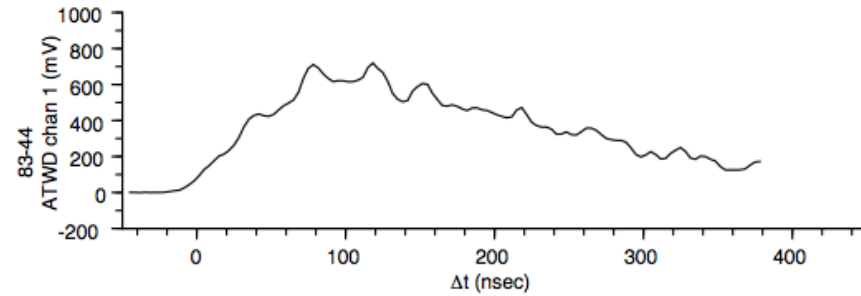

Ch.2

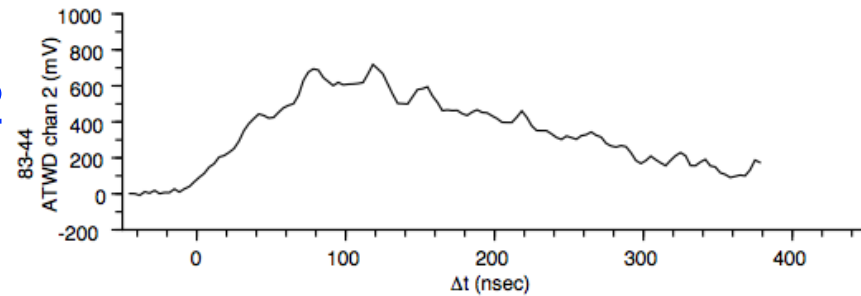

FADC

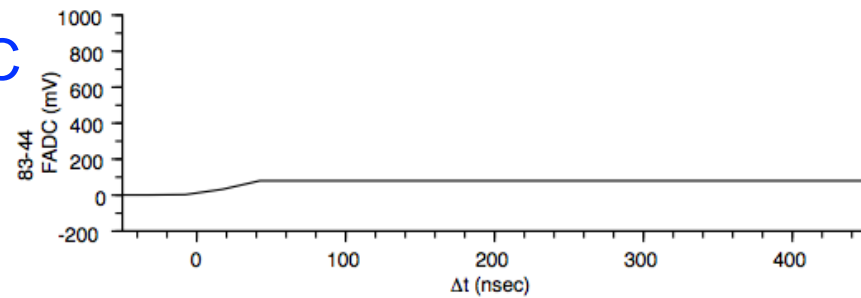

Waveform digitizers “ATWD” Ch. 0,1,2 and “FADC”

Ch.2 needed for large waveforms

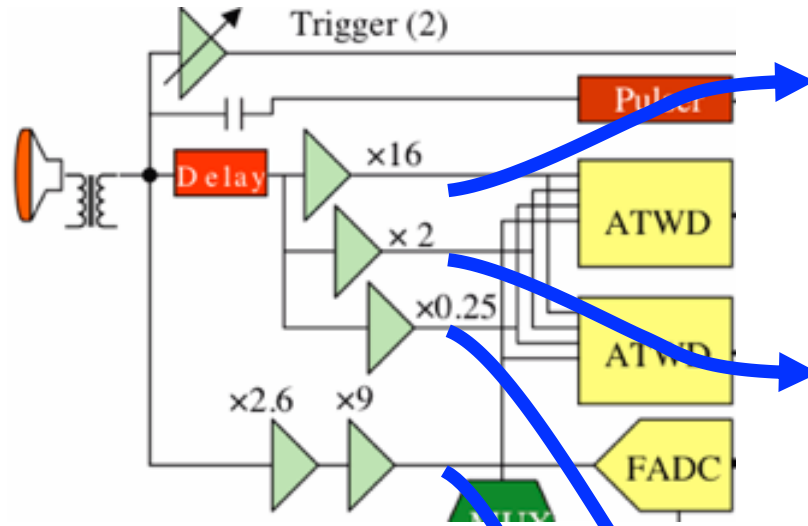

Ch.0

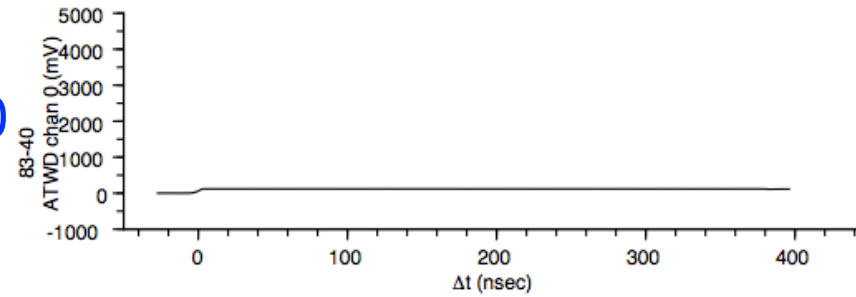

Ch.1

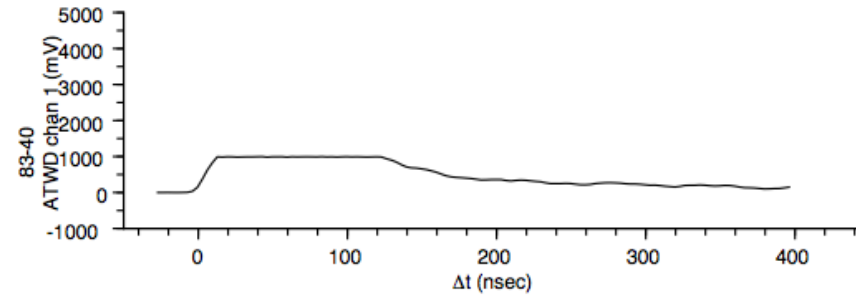

Ch.2

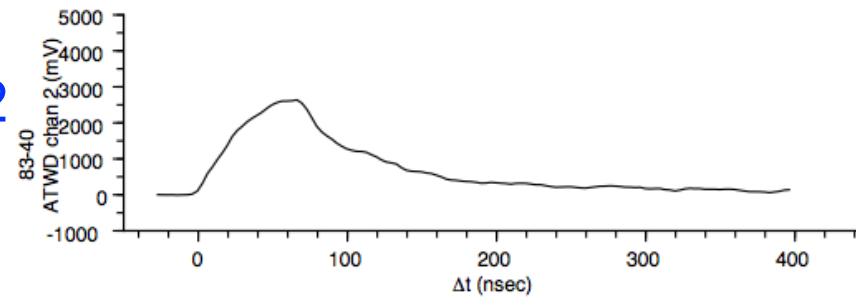

FADC

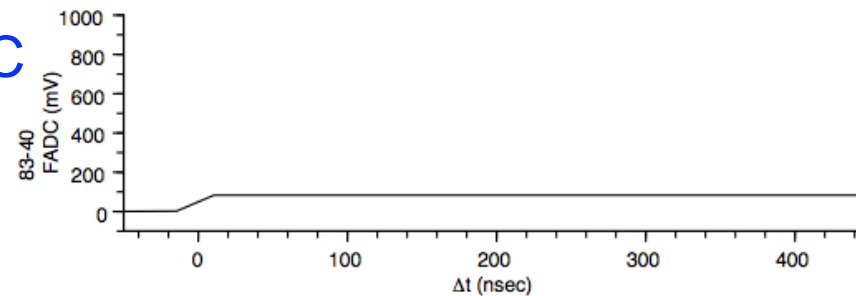

Waveform digitizers “ATWD” Ch. 0,1,2 and “FADC”

FADC needed for long waveforms

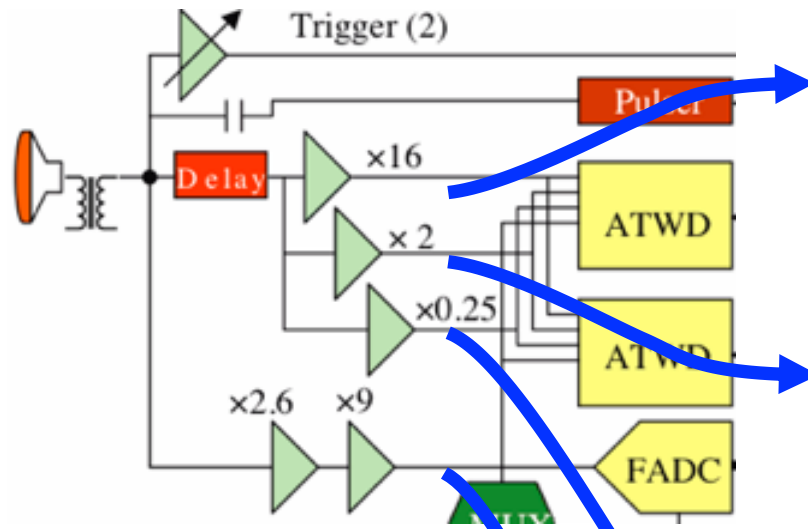

Ch.0

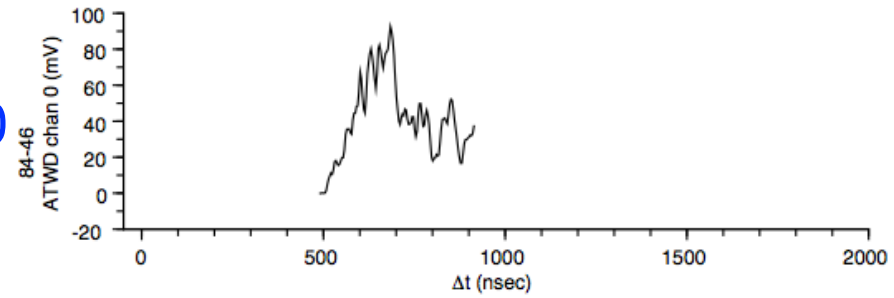

Ch.1

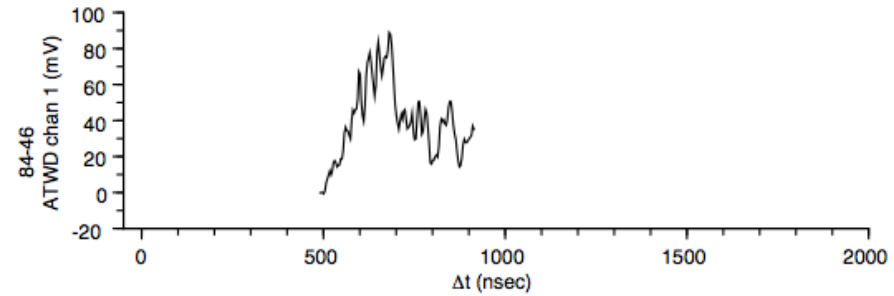

Ch.2

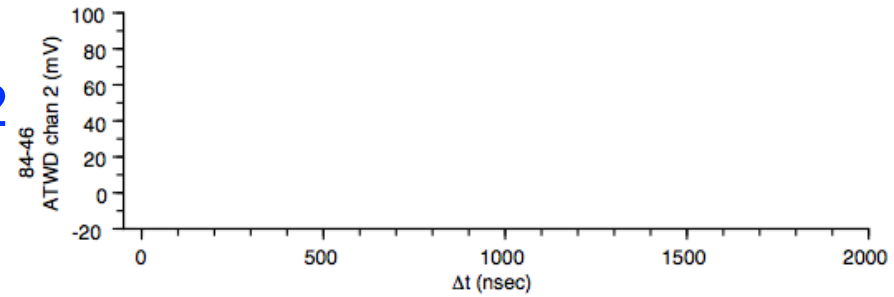

FADC

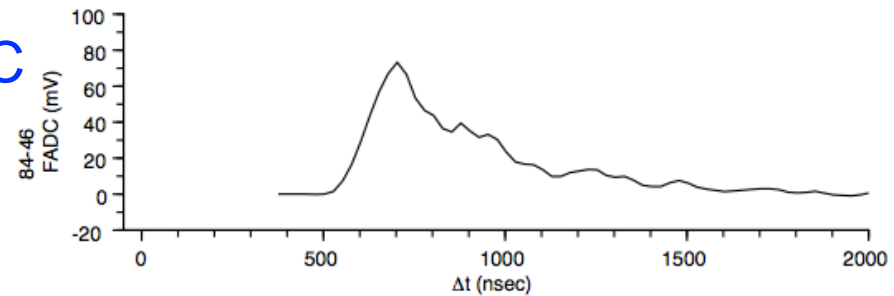

Analog-to-Digital (ADC) Calibration

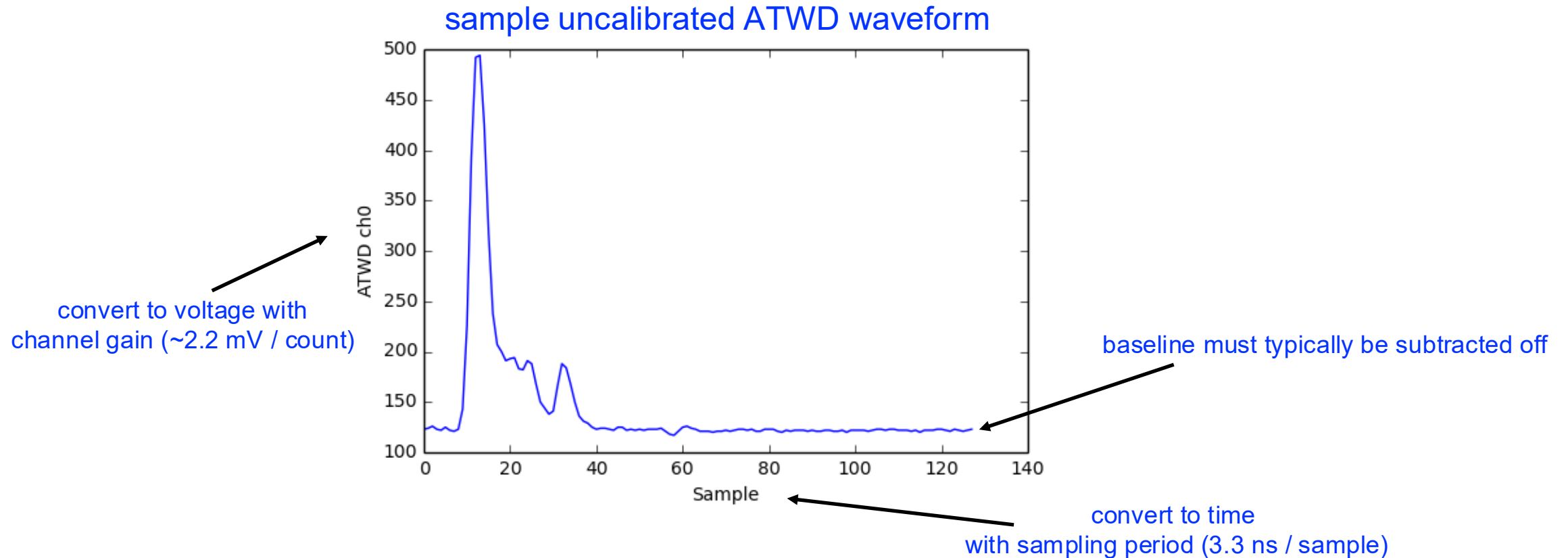

- "Raw" digitizer waveforms are unitless: x-axis is "samples" and y-axis is "counts"
- Both must be calibrated to physical units: time / voltage
- In many ADC uses, this can often be extracted from the schematic
 - input gain + ADC clock
- IceCube DOMs calibrate both axes using known voltage / time inputs ("DOMCal")

Sending waveforms to surface

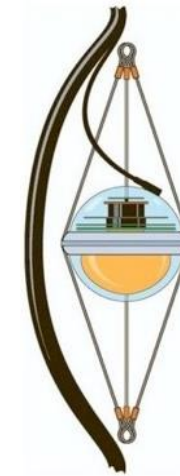
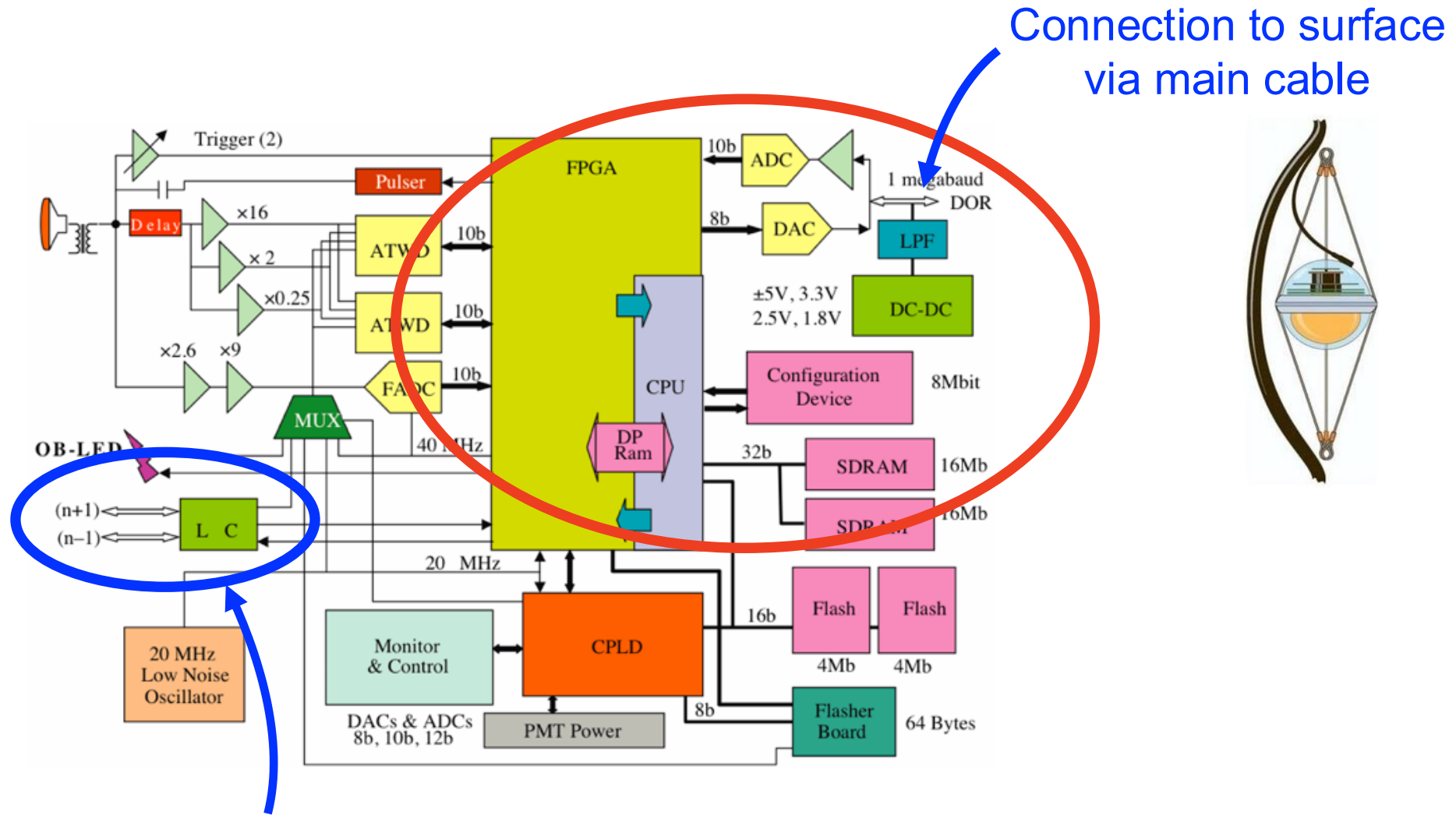

Connection to neighbor
DOMs via main cable

Connection to surface
via main cable

Local Coincidence

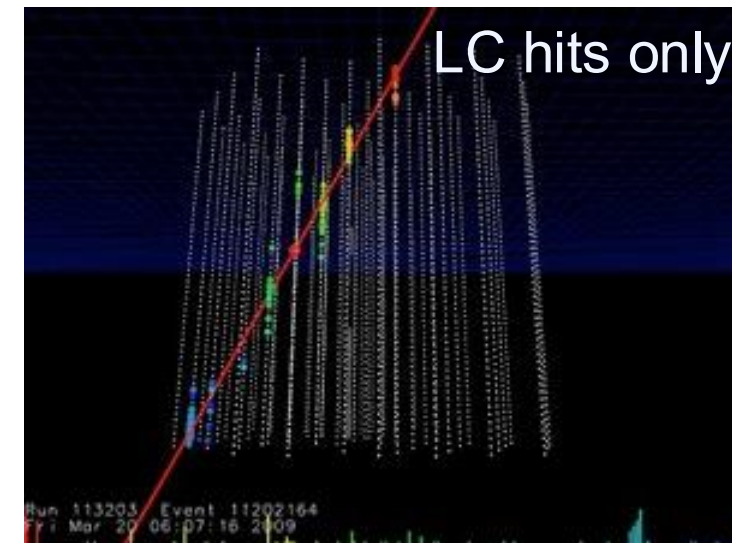
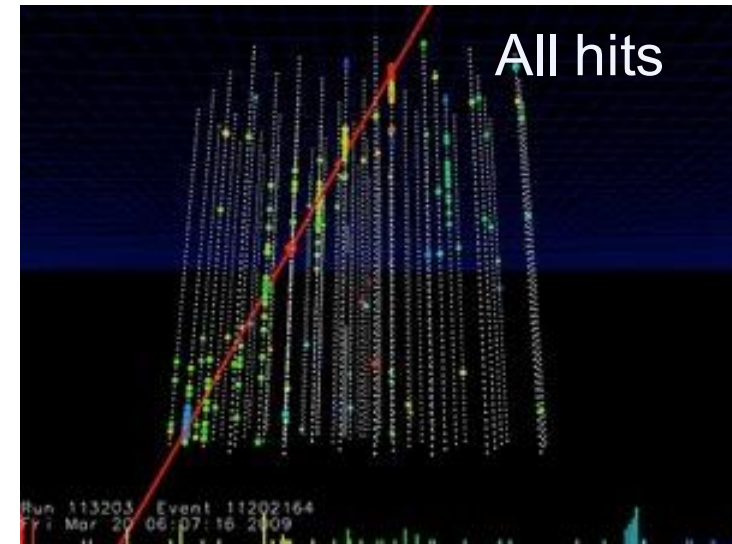
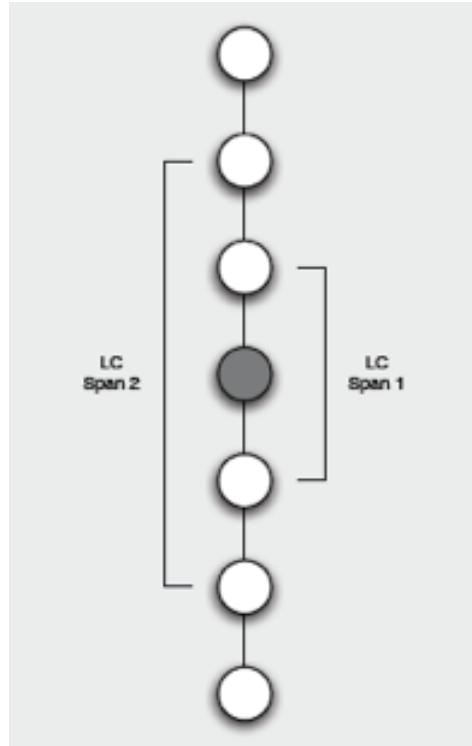
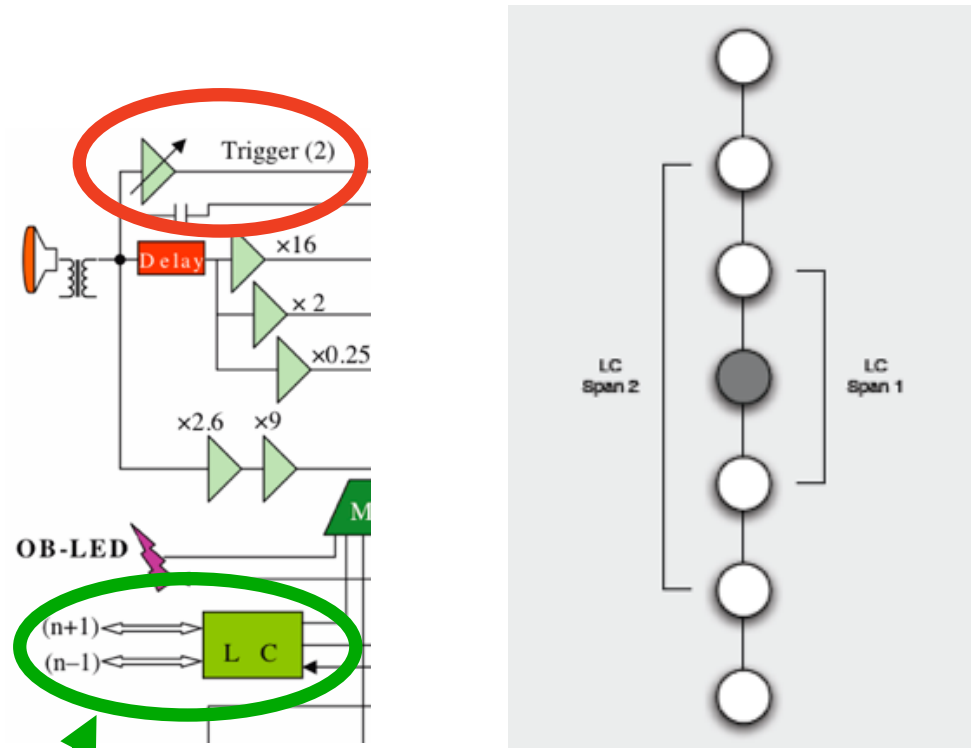

“Local coincidence”

- looks at whether a neighboring DOM also recorded an SPE
- 1 μ sec time window implemented in FPGA
- Many no-LC hits are from PMT dark noise, others are isolated signal photons

Sending waveforms to surface

- Readouts *with* local coincidence “HLC Readouts”

- Ch.0 + FADC
- Ch.0 + Ch.1 + FADC
- Ch.0 + Ch.1 + Ch.2 + FADC

Include enough channels to accommodate peak amplitude

*Highly compressed ~150 bytes/record
but all information is saved*

- Readouts *without* local coincidence “SLC Readouts”

*Only three samples of FADC are saved
so time of SPE can be determined*

- All readouts are grouped into big chunks and transmitted to surface
- Must stay below 40kB/sec for each DOM, otherwise chunks of data get thrown away (“LBM overflows”)

Data flow and reduction

South Pole System (SPS)

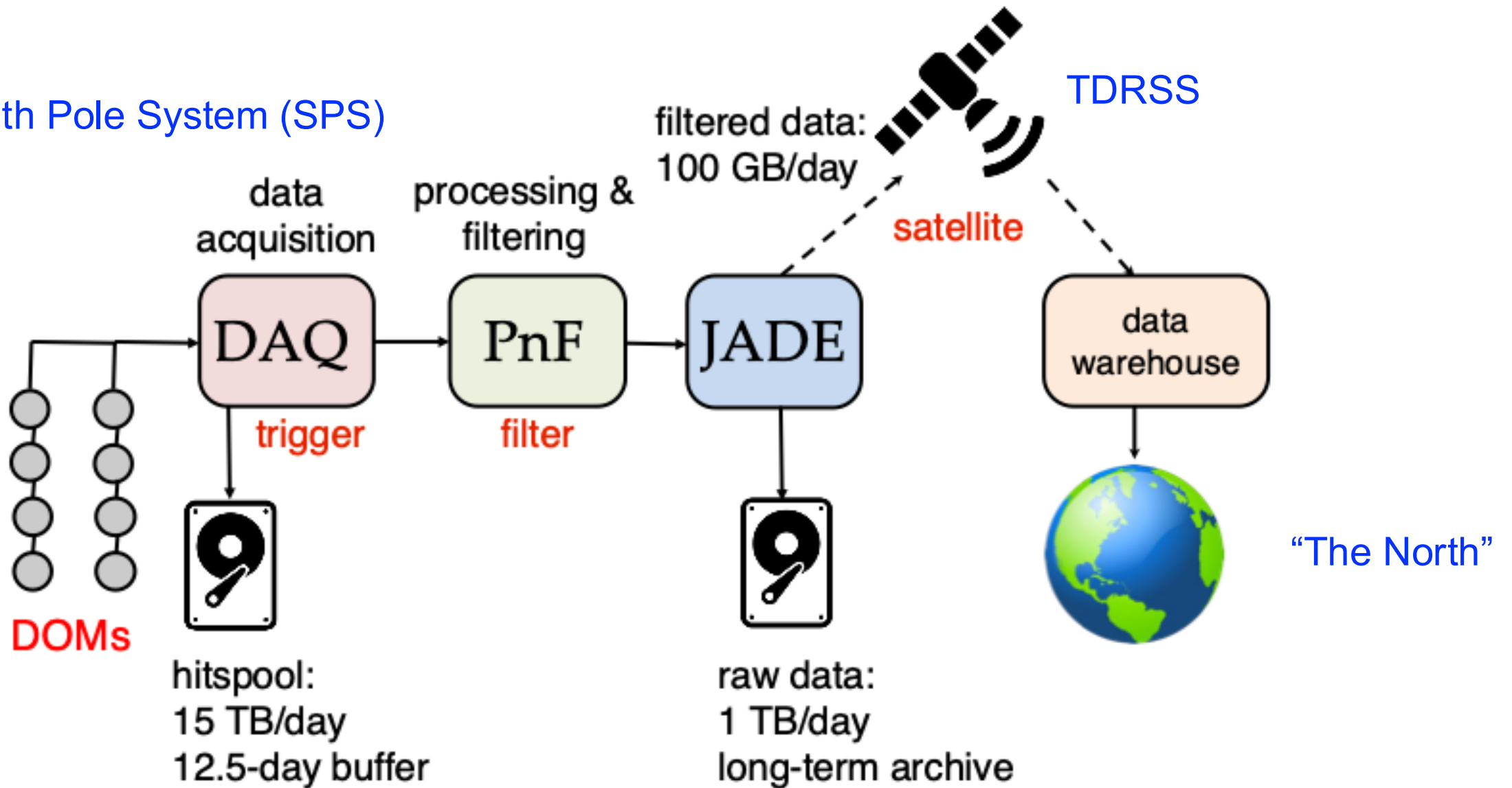



DAQ (Data Acquisition System)

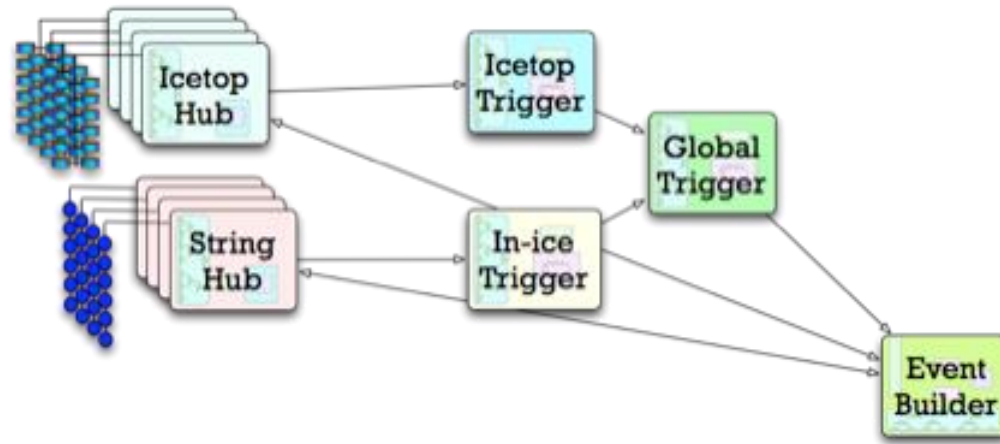

- DOMs generate **hits**: PMT waveform(s) + a timestamp
- We don't want to (and can't) save every hit from every DOM all the time
 - but we do save them for ~12 days in *hitspool* buffers
- The DAQ forms **triggers** when a pattern of hits looks interesting
 - many definitions of “interesting”: muons, cascades, air showers, monopoles...
- Individual triggers are combined into a global readout window, or “event”

Simple Multiplicity Trigger (SMT#)

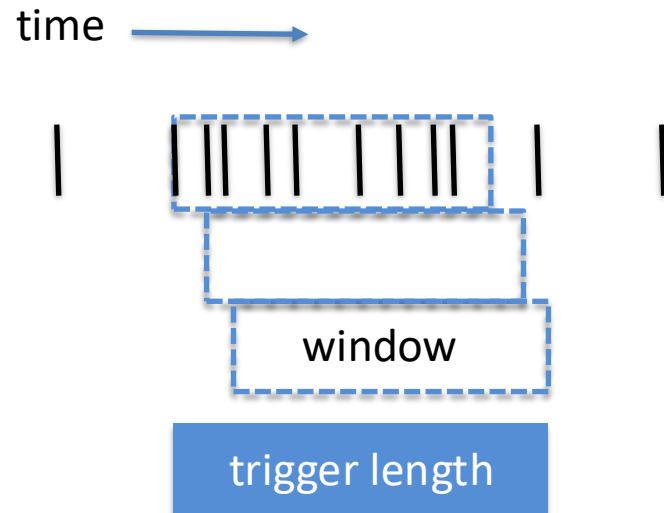

- At least N HLC hits in a sliding time window
- Trigger is extended as long as majority condition satisfied
- Readout windows extend both sides; capture early, late light and SLC hits

Sub-detector	HLC hits	Window (μs)	Rate (Hz)
In-ice	8	5	2100
DeepCore	3	2.5	250
IceTop	6	5	25

Example global trigger

Real data from 2011 (trigger time, trigger length) in ns

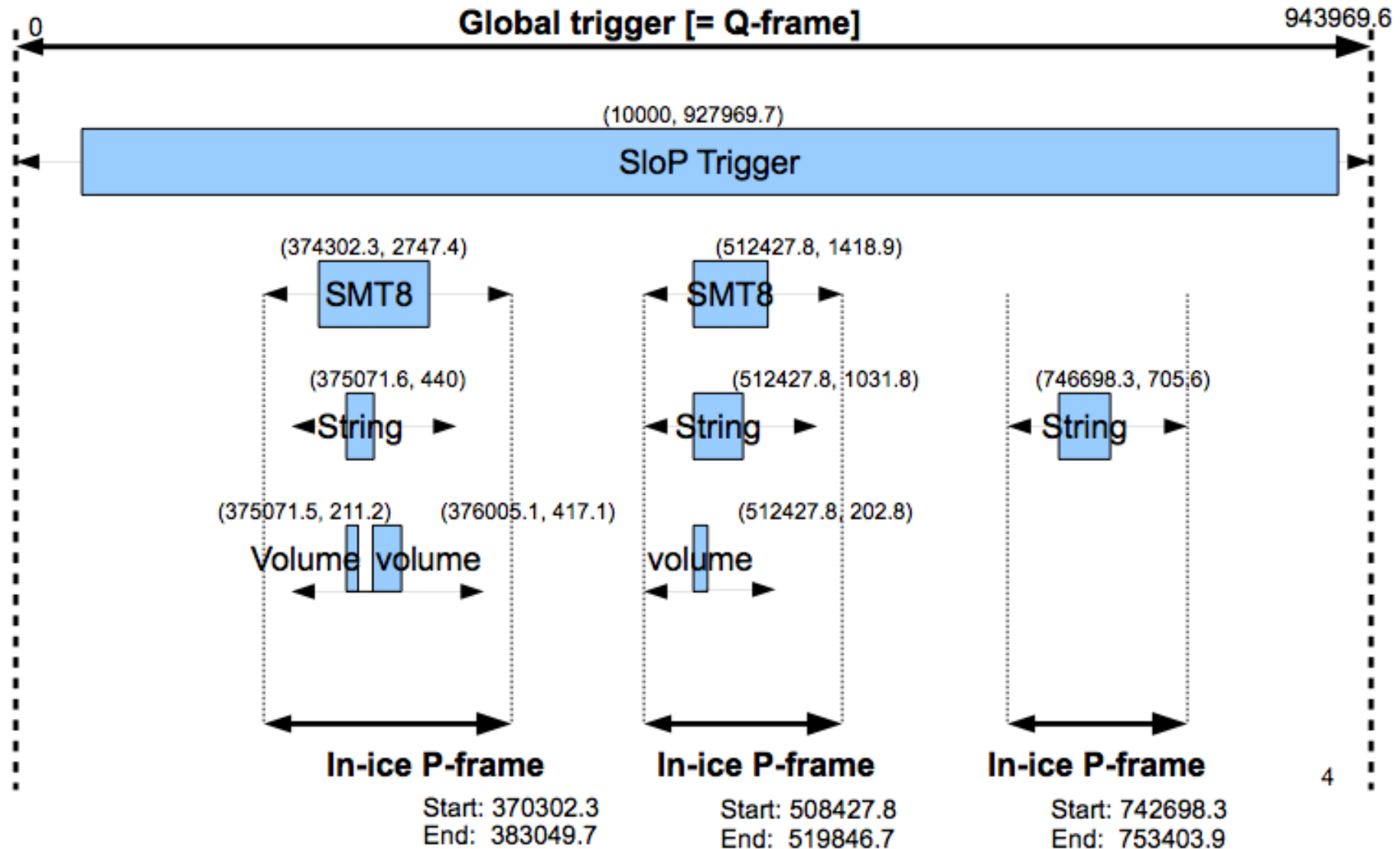

Online Filtering

- DAQ “raw” output: almost 1 TB/day
- satellite bandwidth allocation for IceCube: 105 GB/day
- Options:
 - wait up to a year until we can fly the disks out (what if there’s a problem with the data?)
 - run **filtering** online to look for interesting events; send subset of data over satellite
- **Bonus!** Can trigger other experiments for near-real-time followup
 - HESE, EHE, optical / gamma-ray followup alerts
- Pre-2023: O(20) **Level 1** filter streams for different physics working groups
- Post-2023: send (almost) all events in a highly compressed form
 - SMT12 software retrigger to stay within satellite bandwidth
 - all events still saved to archival disk

SuperDST / WaveDeform

- Basic idea: send highly compressed version of almost every triggered event
 - send reconstructed pulses, not raw waveforms
 - unfold based on template SPE waveforms
- Waveform unfolding algorithm is called WaveDeform

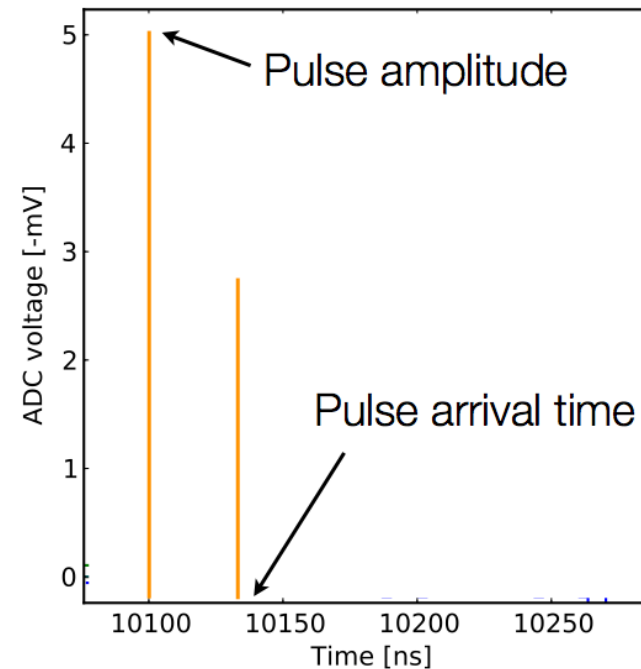
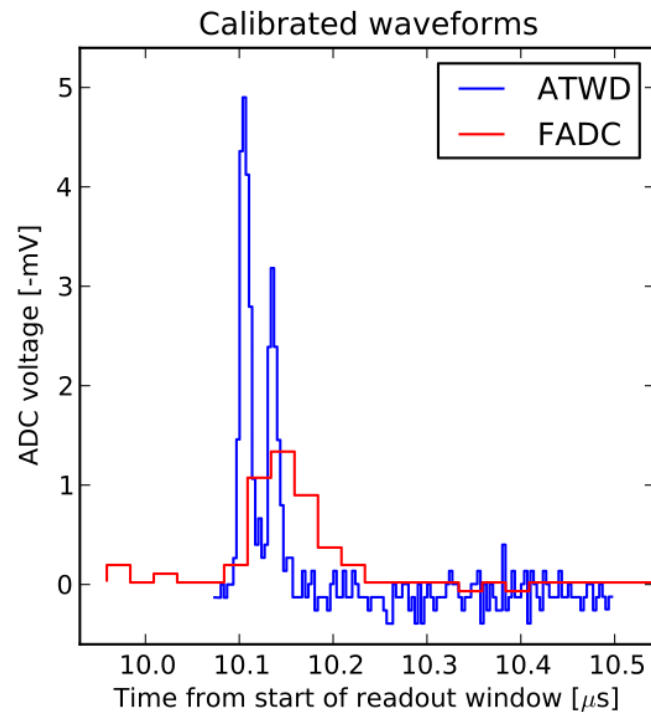

all you need for
many events!

SuperDST reconstructed waveforms

Raw payload: **4394 bytes**

SuperDST: **414 bytes**

Raw waveforms (“seatbelts”) are still sent for

- multichannel hits
- events where the unfolding is bad
- high charge

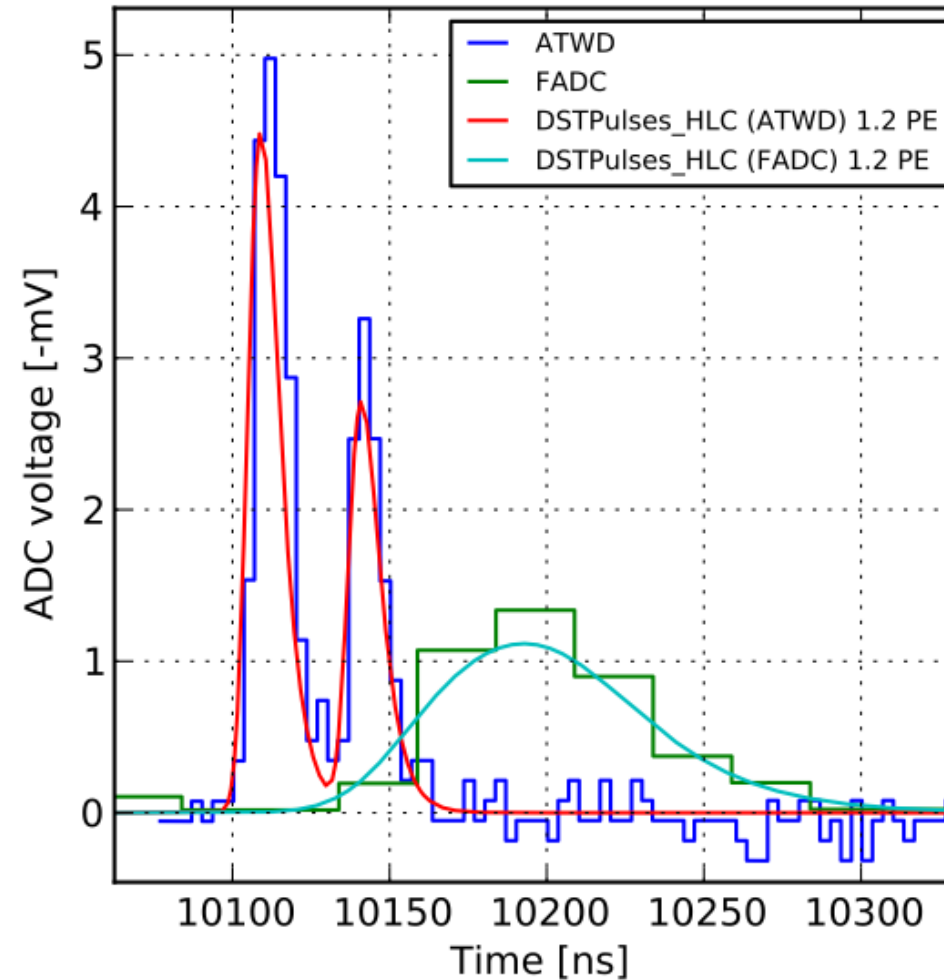

Real-time Alert System

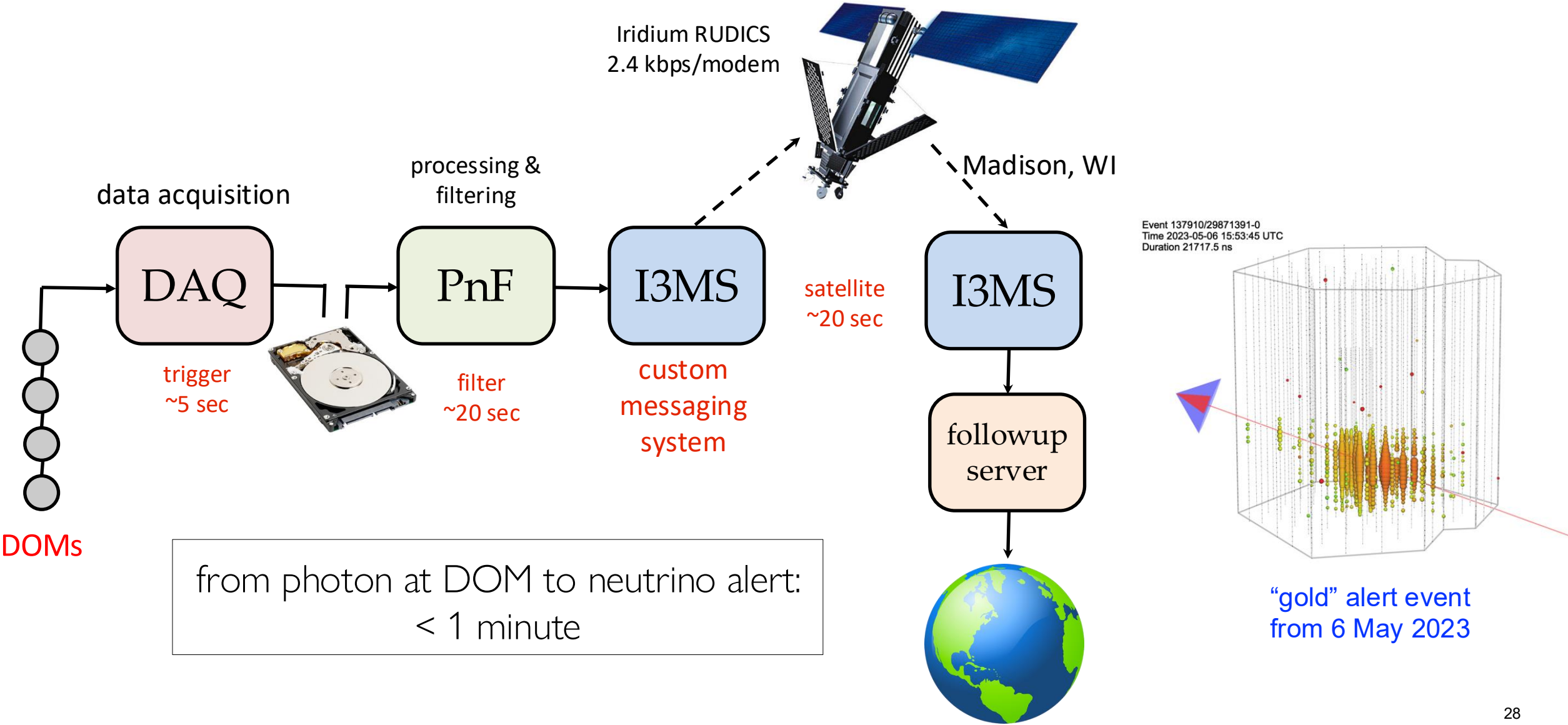

The IceCube Upgrade

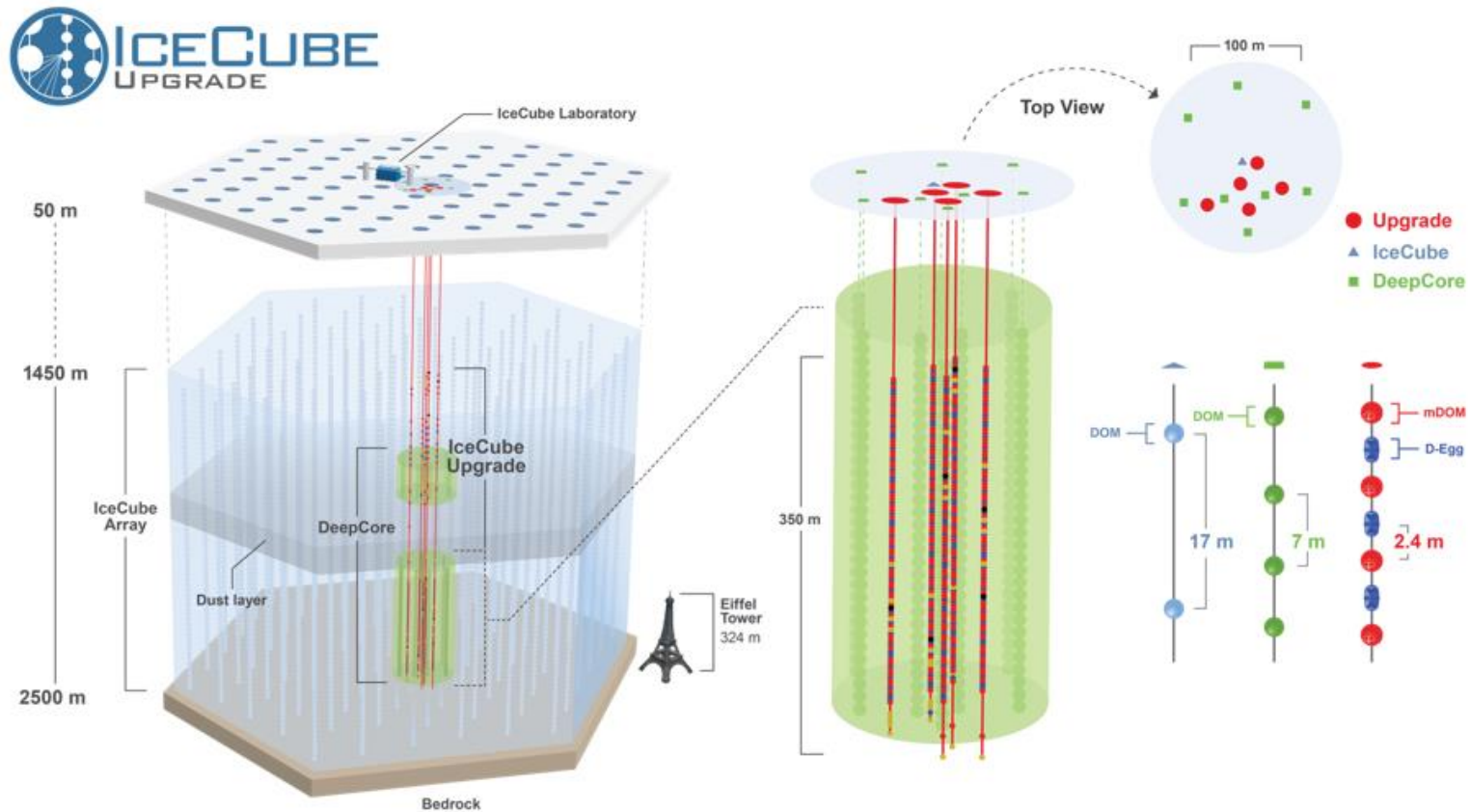

mDOM



D-Egg

- Five new strings deployed in 2025–26 with new DOMs and calibration instrumentation
- DOMs have more PMTs to increase photosensitive area, add directional sensitivity
- New electronics but fundamentally the same design principles

Upgrade in the ICL

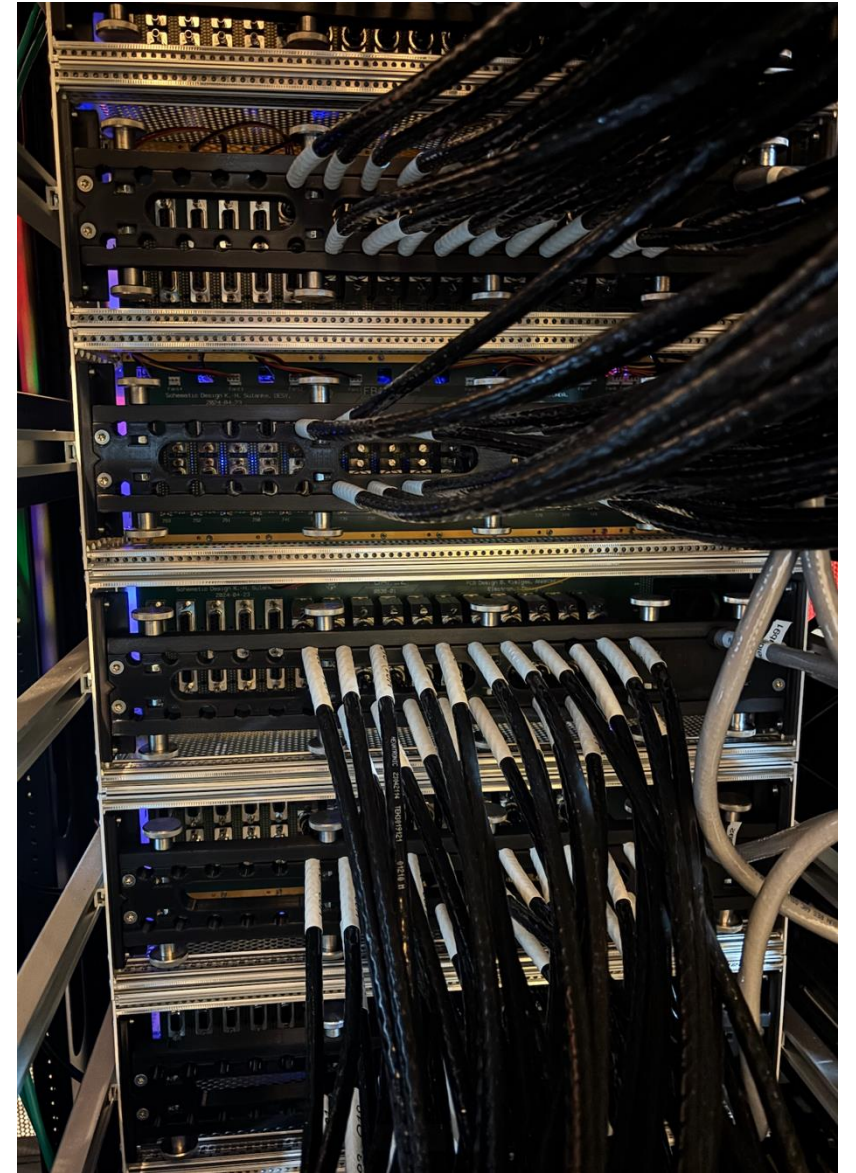

A. Bishop and K. DeHolton installing patch cables from the Upgrade surface cables to the FieldHubs (24–25)

High-level differences between Gen1 and Upgrade

- Multiple PMTs per module
 - they work the same way, just individually smaller
- Digitization is simpler
 - off-the-shelf ADCs
 - single gain channel / PMT (except for LOM)
- No wired local coincidence
 - implications for cable bandwidth, triggering
- DOM firmware, software is new
 - new: SPE waveform unfolding in the DOM
 - i.e. “feature extraction” or FEX
- Surface readout electronics, firmware, software are new
- Data encodings are different, but same idea: triggered events contain a series of timestamped PMT hits vs. time



Upgrade rack in ICL

For real-time detector status:

<http://live.icecube.wisc.edu>

Some sources for more information

- Previous years' bootcamp / summer school presentations
<http://wiki.icecube.wisc.edu/index.php/Bootcamp>
- IceCube PMT Paper
<https://docushare.icecube.wisc.edu/dsweb/Get/Document-53922/>
- IceCube DOM-DAQ Paper
[“The IceCube Data Acquisition Subsystem: Signal Capture, Digitization, and Time-Stamping”
Nuclear Instruments and Methods in Physics Research A 601 \(2009\) 294–316](#)
<https://docushare.icecube.wisc.edu/dsweb/Get/Document-48249/>
- **IceCube Detector Paper**
[“The IceCube Neutrino Observatory: instrumentation and online systems”
Journal of Instrumentation 12 \(2017\) P03012](#)
<https://arxiv.org/pdf/1612.05093.pdf>
- Wiki page for LED flashers
<http://wiki.icecube.wisc.edu/index.php/Flashers>
- Docushare areas and personal websites
Docushare: <https://docushare.icecube.wisc.edu/dsweb/View/Collection-410>
Jerry Przybylski: http://icecube.lbl.gov/~gtp/site_map.html#ForIceCube
Thorsten Stezelberger: <http://glacier.lbl.gov/~thorsten/ATWD/>
Nobuyoshi Kitamura: <http://icecube.wisc.edu/~kitamura/>
- N.B. many more details being taken care of like “toroid droop”, baseline offsets, channel non-matching, PMT saturation, afterpulses, more precise optical sensitivity measurement, ...

Some sources for more information

- I3Live documentation:
<https://live.icecube.wisc.edu/doc/main/>
- TFT proposals:
http://wiki.icecube.wisc.edu/index.php/Trigger_Filter_Transmission_Board
- SuperDST:
<http://software.icecube.wisc.edu/documentation/projects/dataclasses/superdst.html>
<http://wiki.icecube.wisc.edu/index.php/SuperDST>
<https://events.icecube.wisc.edu/indico/contributionDisplay.py?contribId=140&sessionId=4&confId=33>
- Supernova DAQ:
<http://wiki.icecube.wisc.edu/index.php/Supernova>
- Monitoring:
<http://wiki.icecube.wisc.edu/index.php/Monitoring>
- Problem DOMs:
https://live.icecube.wisc.edu/dom_problems/
http://wiki.icecube.wisc.edu/index.php/Problem_DOMs (historical)
- On Slack:
[#everything-monitoring](#): monitoring shifter support
[#daq-dev](#), [#live-dev](#): data acquisition and I3Live experts
[#realtime](#): realtime neutrino event discussion

Extra Slides

Why so many channels and digitizers?

- Fast digitizers are power hungry, and the ATWD design was the alternative
 - When triggered, the ATWD quickly stores 128 samples of waveform, then digitizes these
 - During the digitization period, the ATWD is disabled, so a second one is provided to avoid losing additional hits (“ping-pong”)
- The FADC is a slower digitizer to cover the case of longer waveforms
- Each channel had only 10 bit resolution so could not accommodate the dynamic range from small signals to large signals... thus needed ch.0/1/2
- But we pay a price in complexity and some funky problems when combining information from different gain channels

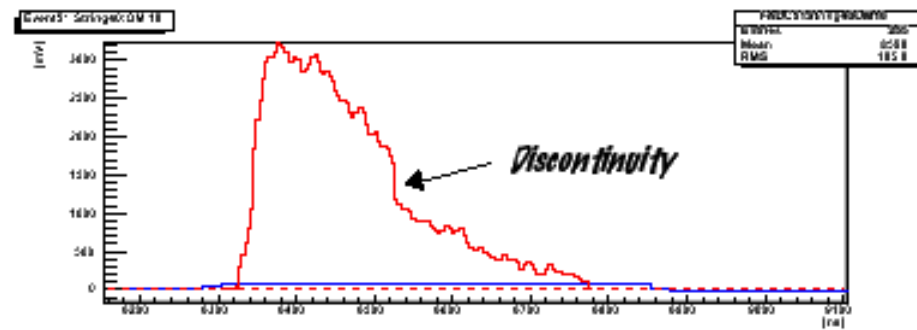

ATWD peculiarities

- Each ATWD has a “fingerprint” or pedestal pattern which must be subtracted from the waveform (happens automatically in the software)

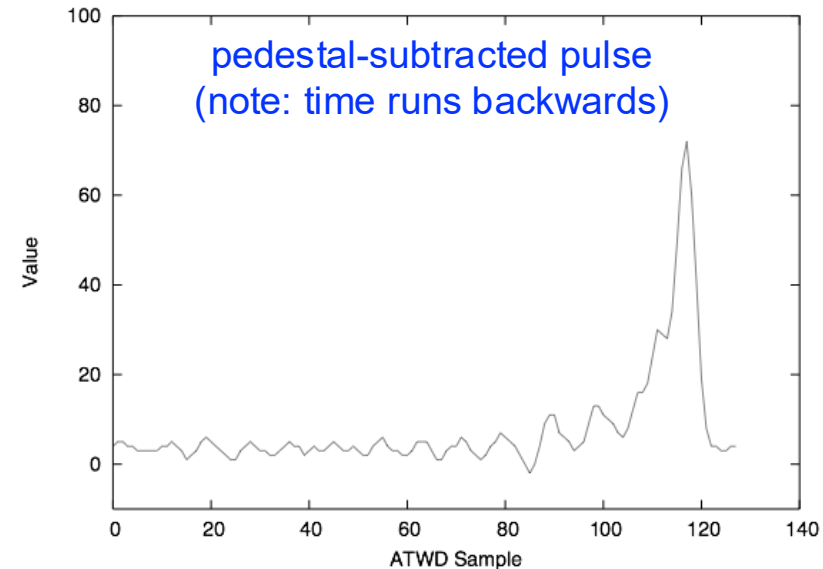
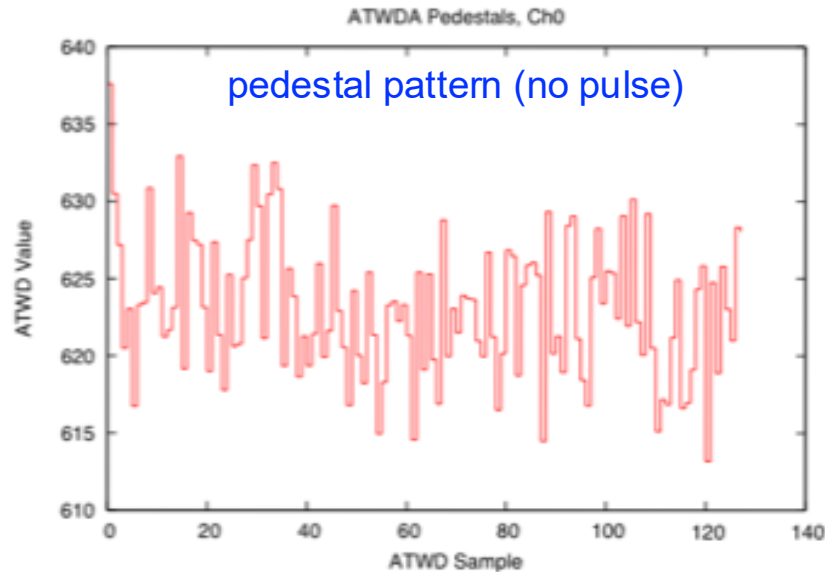

- Baseline voltage is very sensitive to DOM conditions; baselines are measured from previous runs and subtracted before pulses analyzed
- ATWD documentation:
http://docushare.icecube.wisc.edu/docushare/dsweb/Get/Document-21613/atwd_manual.pdf
<http://glacier.lbl.gov/~thorsten/ATWD/>

Trigger Types

- **Simple Multiplicity Trigger (SMT)**
 - N HLC hits or more in a time window
 - Example: InIce SMT8 with $N_hits \geq 8$ in $5 \mu s$
 - readout window around this captures early and late hits ($-4 \mu s, +6 \mu s$)
- **String** trigger (a.k.a. Cluster trigger in DAQ-land)
 - N HLC hits out of M DOMs on a string in a time window
 - Example: 5 hits from a run of 7 adjacent DOMs in a time window of 1500 ns
- **Volume** trigger (a.k.a Cylinder trigger in DAQ-land)
 - simple majority of HLC hits (SMT4) with volume element including one layer of strings around a center string
 - cylinder height is 5 DOM-layers (2 up and down from the selected DOM).
- **Slow Particle** trigger (SLOP)
 - slow-moving hits along a track
 - lengths of the order of $500 \mu s$ and extending up to milliseconds
- **Fixed Rate** trigger, **Minimum Bias** trigger, **Calibration** trigger

SLOP Trigger

- Consider pairs of hits with LC condition
- Remove pairs if too close in time (T_{prox})
- Form 3-tuples of pairs within time window (T_{min}, T_{max})
- Track-like check on 3-tuples:
 - minimum inner angle α_{min}
 - normalized velocity difference v_{rel}
- Condition on minimum number of 3-tuples

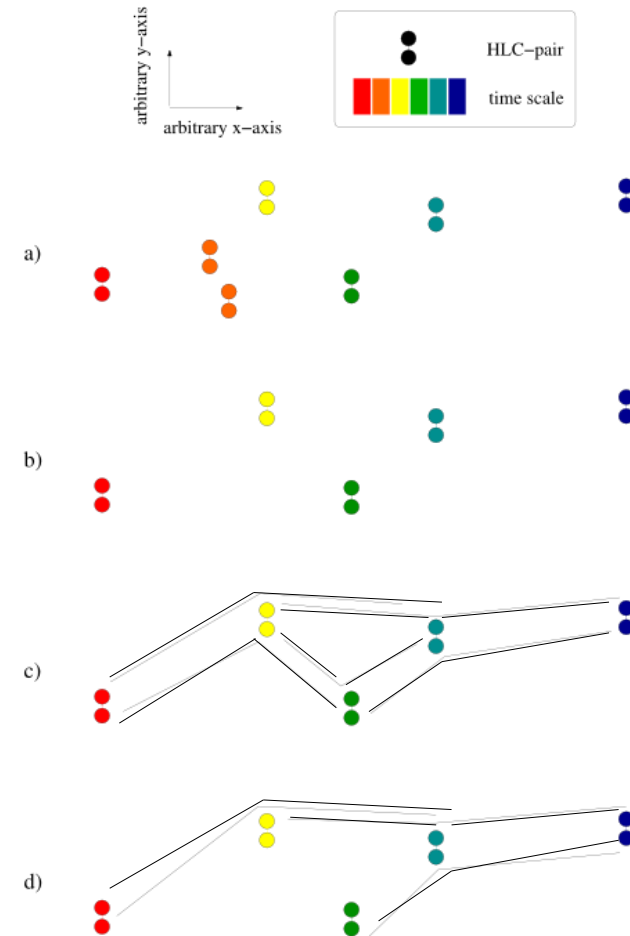

Trigger	N_{tuple}	T_{prox} (μs)	T_{min}, T_{max} (μs)	α_{min}	v_{rel}	Rate (Hz)
SLOP	5	2.5	[0, 500]	140°	0.5	12

Topological Triggers

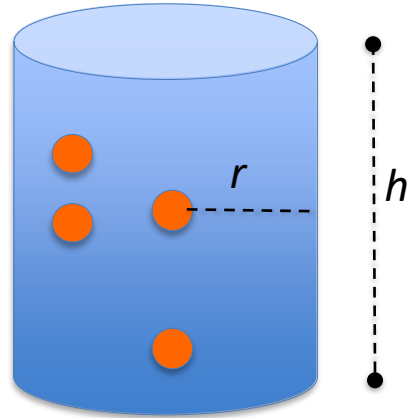

Volume trigger: N hits within a cylindrical volume around DOM in a time window



String trigger: N hits of M DOMs on a string in a time window

Trigger	HLC hits	Topology	Window (μs)	Rate (Hz)
Volume	4	cylinder $r=175\text{m}$, $h=75\text{m}$	1	3700
String	5	of 7 DOMs on string	1.5	2200

Specialized trigger: monopoles

T. Glüsenkamp

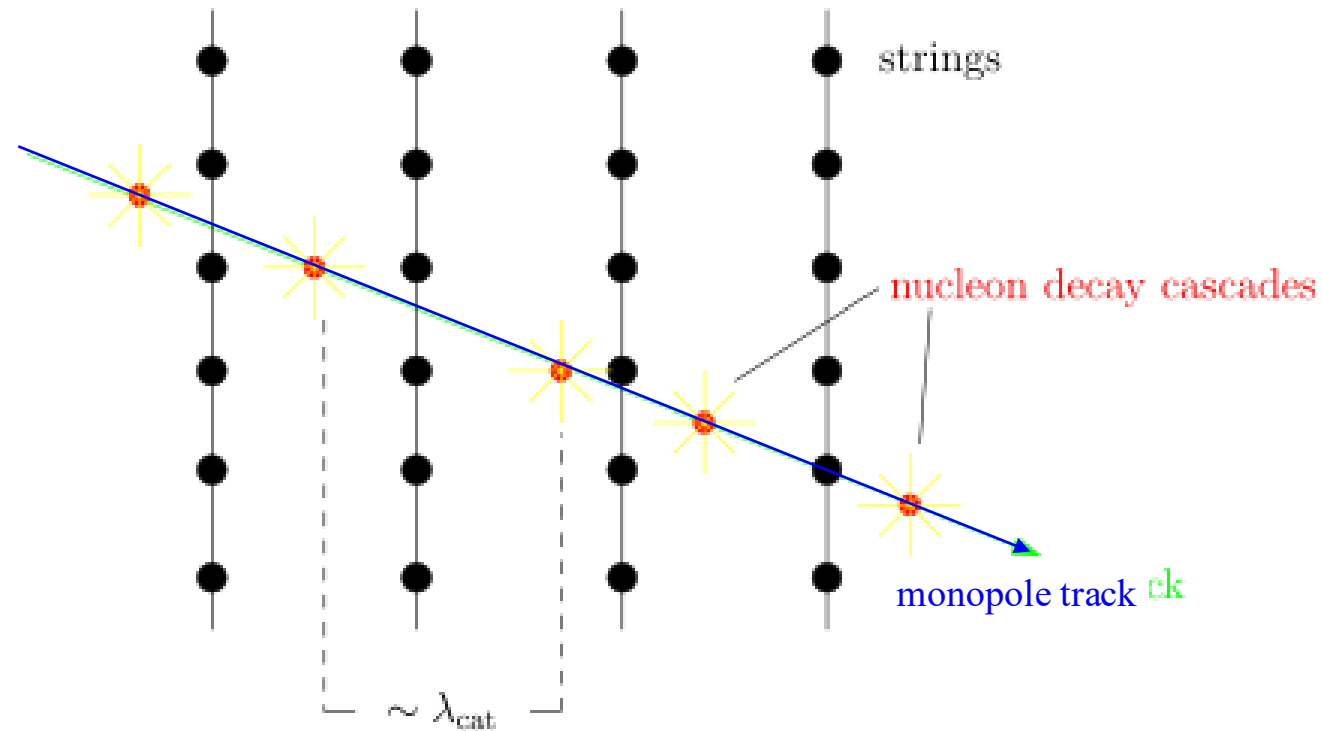

Signature of some exotic particles (magnetic monopoles, Q-balls, etc.):
slow ($v \sim 0.001\text{--}0.01c$) tracks with intermittent cascades

Slow particle speed means a longer trigger window is needed!

Trigger Readout

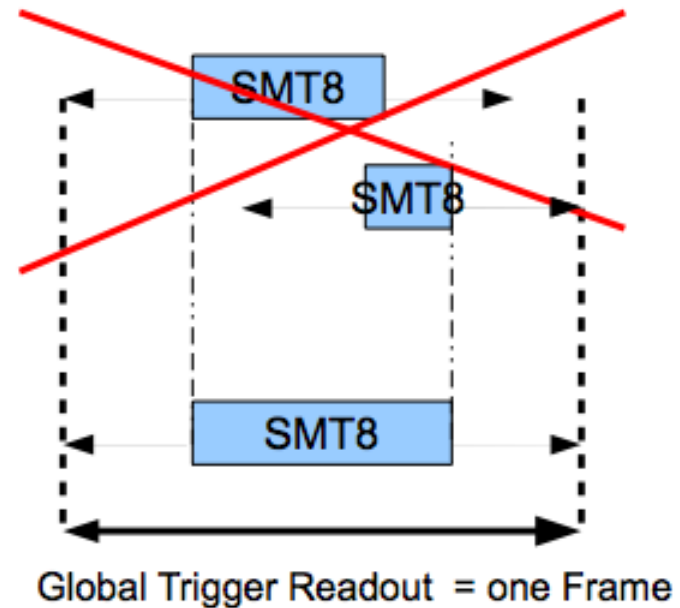
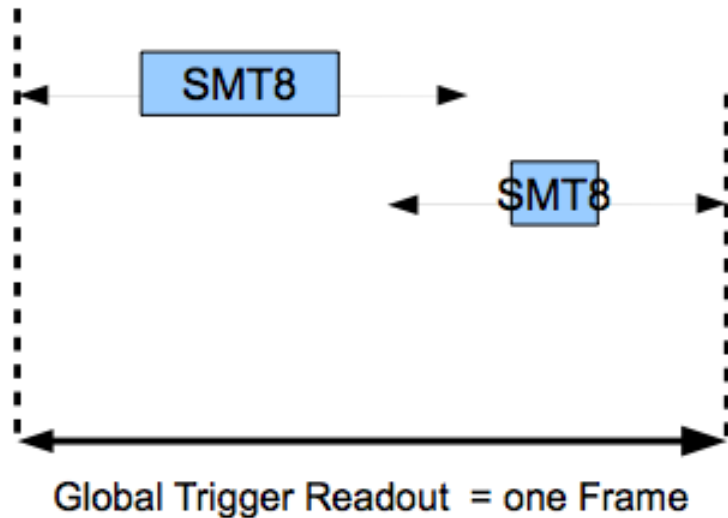
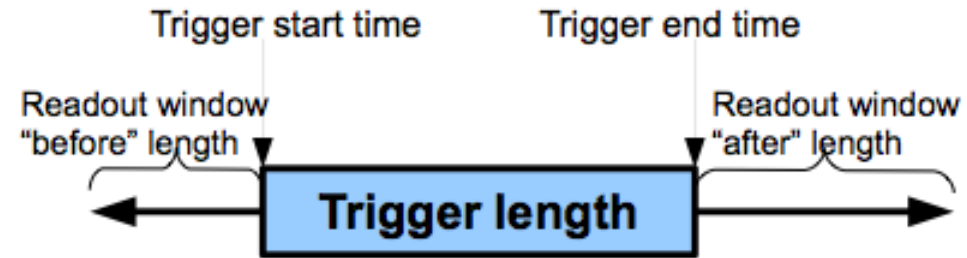

Trigger rate example

Trigger	Rate (Hz)
InIce SMT8	2113
DeepCore SMT3	256
SLOP	13.3
FRT	0.0333
String	2240
Volume	3727
MinBias	59.4

Event rate from Run 120029: 2742 Hz

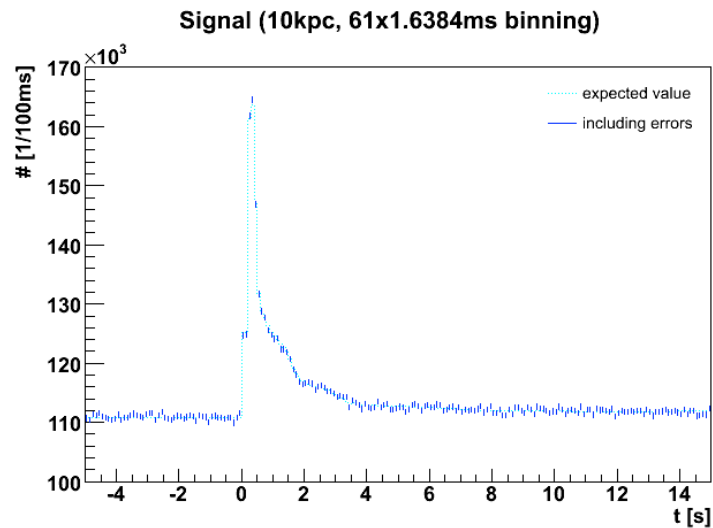
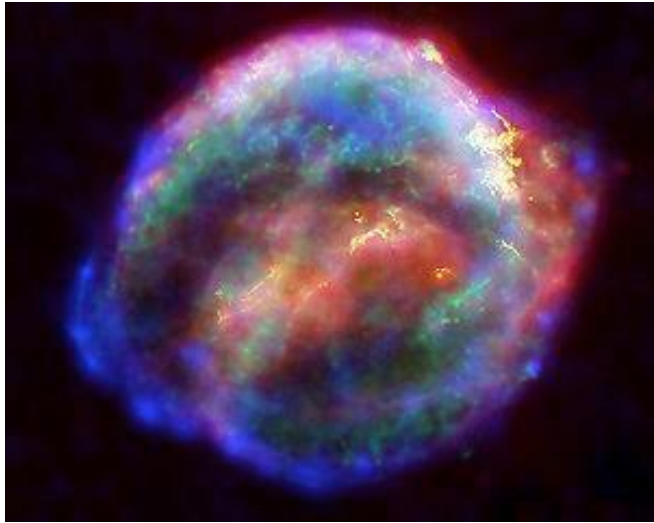

- IceCube can also detect nearby supernovae: detection method very different
- The **Supernova DAQ** runs in parallel to the “normal” DAQ after the StringHubs
- Collects noise rates vs. time for all in-ice DOMs
 - looks for global rise in noise rates across detector
 - sends alerts over Iridium satellite constellation to SNEWS
 - sends SMS alerts and e-mails

What is a filter?

- A **filter** is the first stage of analysis that looks for a type of physics event at SPS, to send over the satellite
- Each working group proposes its own filter(s): muon, cascade, etc.
- The filters are run by **PnF**, which calibrates and cleans the data, looks for events containing triggers that the filters are interested in
 - fast, first-guess algorithms run on most events
 - loose “quality cuts” throw away the junk
- PnF then farms the events out to a computer cluster at pole

Filter Examples (pre-2023 physics run)

- Muon filter
 - hit cleaning -> calibration -> pulse extraction -> fast track reconstruction -> direction-dependent quality cuts
- Cascade filter
 - events that look more blob-like than track-like (ter of inertia ratio)
- EHE filter
 - high-energy events (total NPE)
- Sun & Moon filter
 - events coming from current Sun and Moon positic (WIMPs, moon shadow)
- IceTop filter
 - quality air shower events (also: in-ice coincidences)
- quite a few others for specific analyses

Muon Filter Passing Rate (simulation)

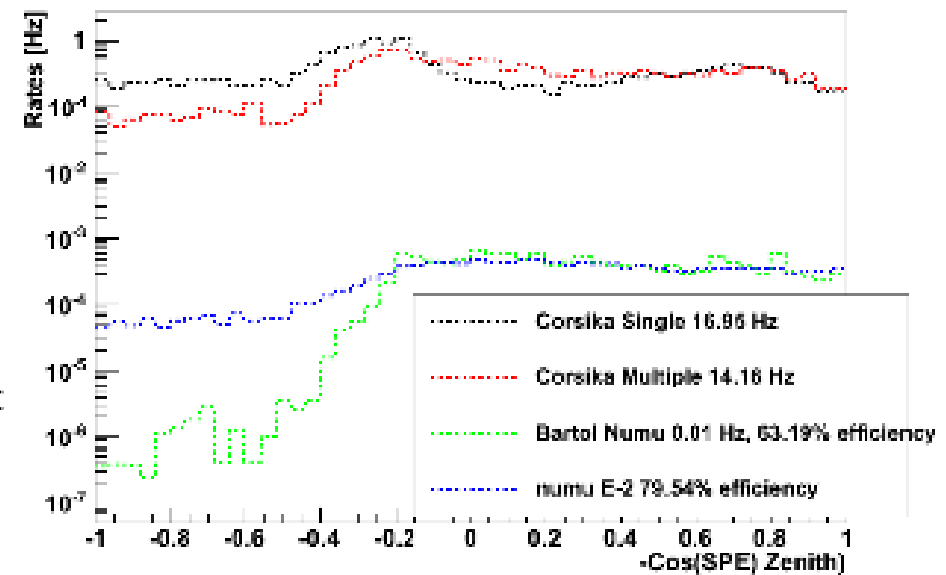

Processing and Filtering (PnF)

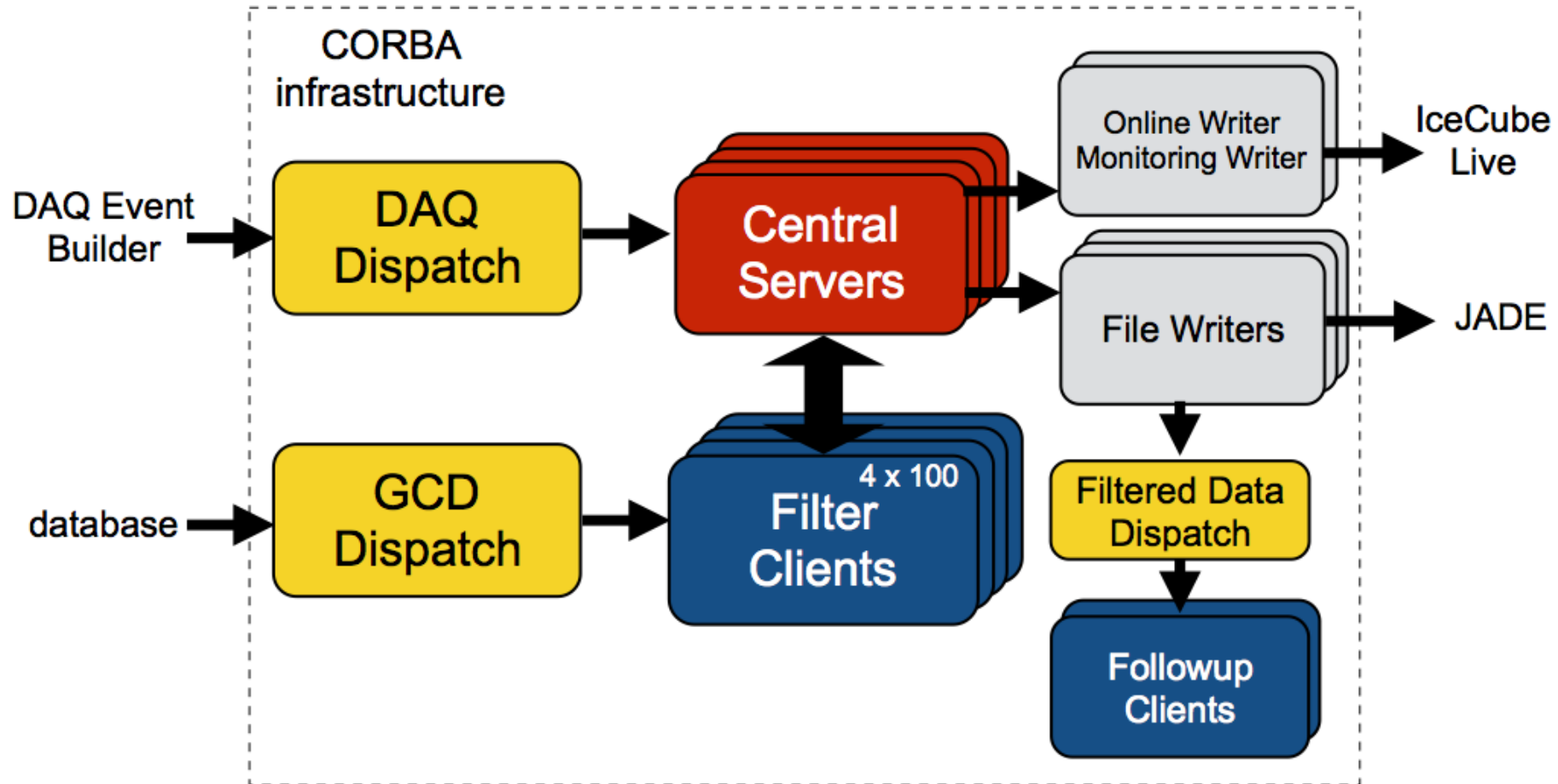

Triggering, Filtering, and Transmission Board

- How to balance needs of everyone wanting:
 - special DAQ trigger
 - special physics event filter
 - lots of satellite bandwidth
- TFT board reviews proposals once a year
 - changes are made at the “physics run start”, typically in May
- Wiki is a good place to start for trigger / filter descriptions

http://wiki.icecube.wisc.edu/index.php/Trigger_Filter_Transmission_Board

Experiment Control and I3Live

