

Calibration and the Ice Model

Dawn Williams

University of Alabama

IceCube Bootcamp 2022

IceCube Detector and Ice references

- **The IceCube Neutrino Observatory: Instrumentation and Online Systems**
 - <https://arxiv.org/abs/1612.05093>
- **Calibration and Characterization of the IceCube Photomultiplier Tube**
 - <https://arxiv.org/abs/1002.2442>
- **The IceCube Data Acquisition System: Signal Capture, Digitization, and Timestamping**
 - <https://arxiv.org/abs/0810.4930>
- **Measurement of South Pole ice transparency with the IceCube LED calibration system**
 - <https://arxiv.org/abs/1301.5361>
- **Evidence of Optical Anisotropy of the South Pole Ice**
 - <https://arxiv.org/pdf/1309.7010.pdf>
- **Photon Propagation through Birefringent Polycrystals**
 - <https://internal-apps.icecube.wisc.edu/reports/details.php?type=report&id=icecube%2F201902001>
- **Energy Reconstruction Methods in the IceCube Neutrino Telescope**
 - <https://arxiv.org/abs/1311.4767>
- **In-situ calibration of the single-photoelectron charge response of the IceCube photomultiplier tubes**
 - <https://arxiv.org/abs/2002.00997>

Acknowledgment

- The ice model is developed in the IceCube Calibration working group
- Much of the material in this presentation comes from the work of Ryan Bay, Dima Chirkin, Martin Rongen and Chris Wendt and many others

IceCube

Strings are numbered
1-86

DOMs are numbered
1-60, top to bottom
(in ice)

Surface (IceTop)
DOMs are numbered
61-64, not used in
flasher analysis

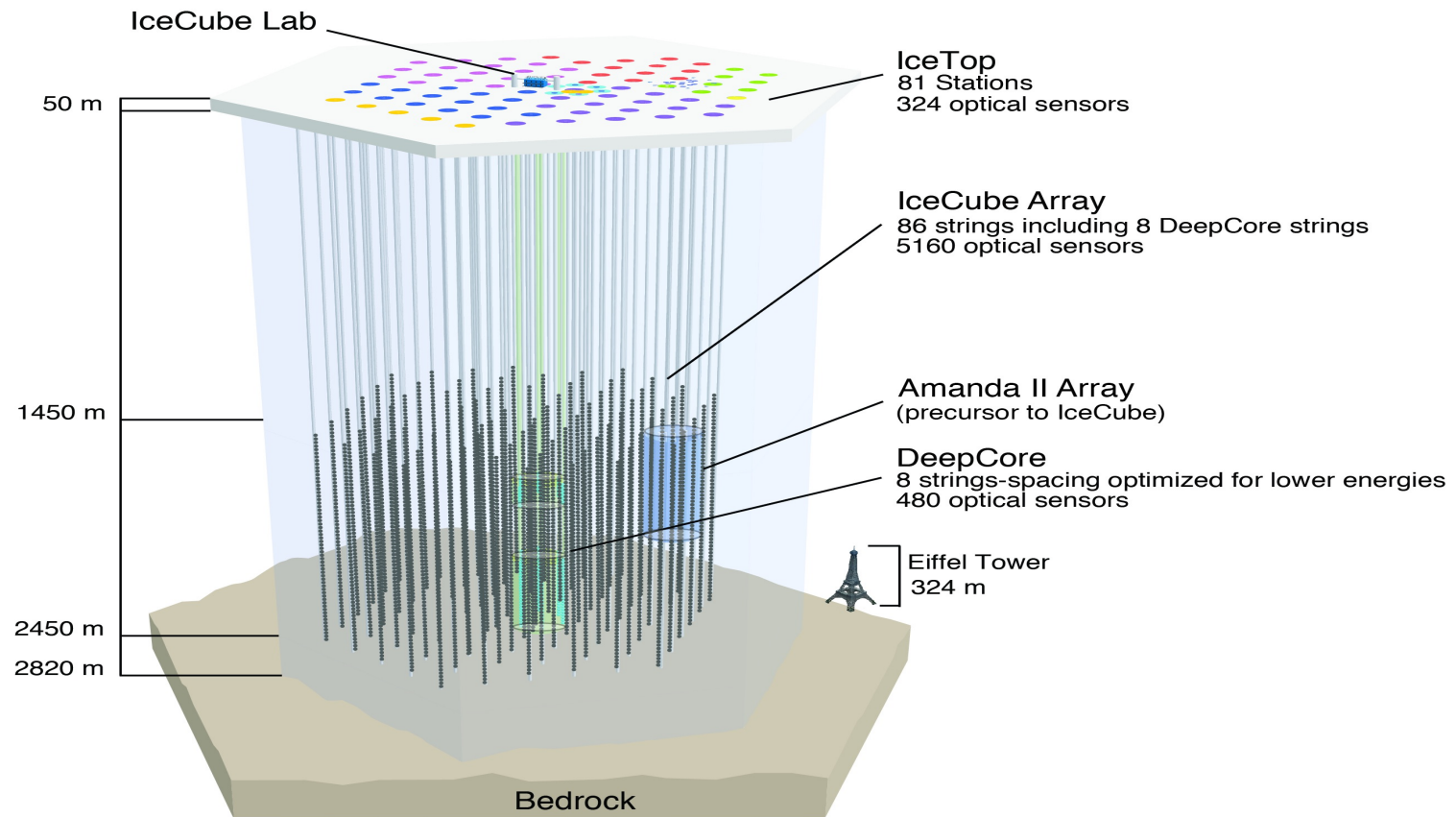

IceCube Strings

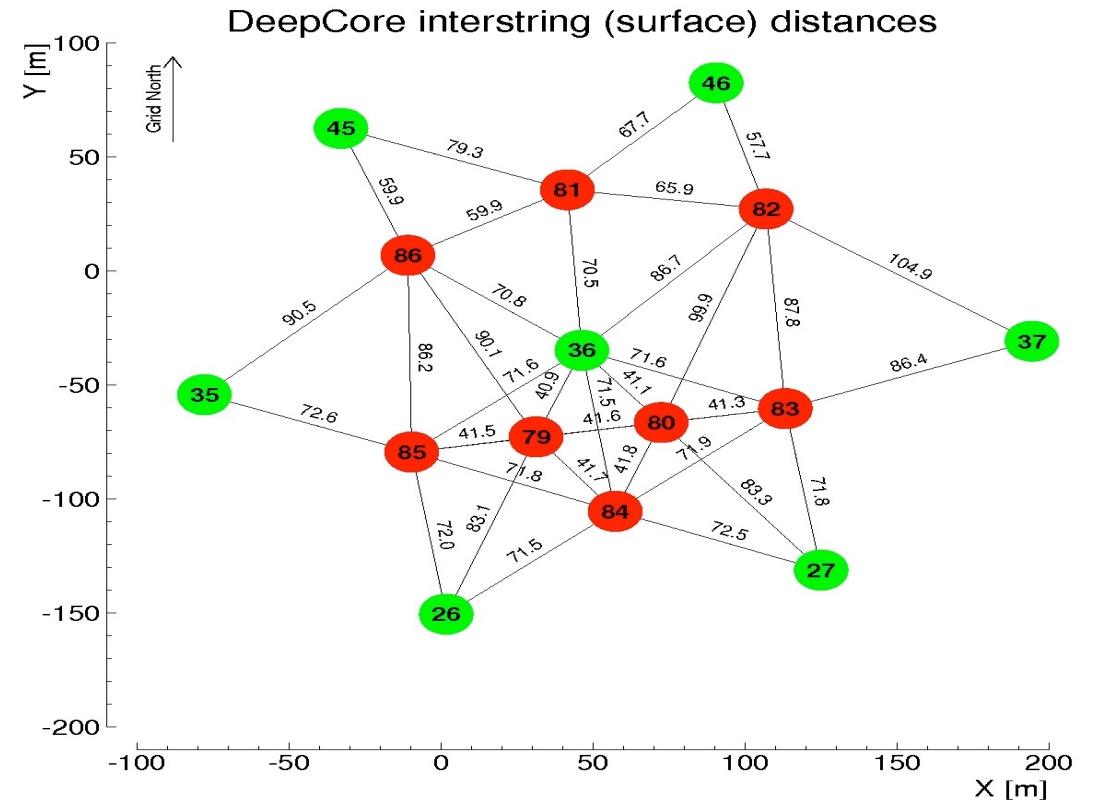
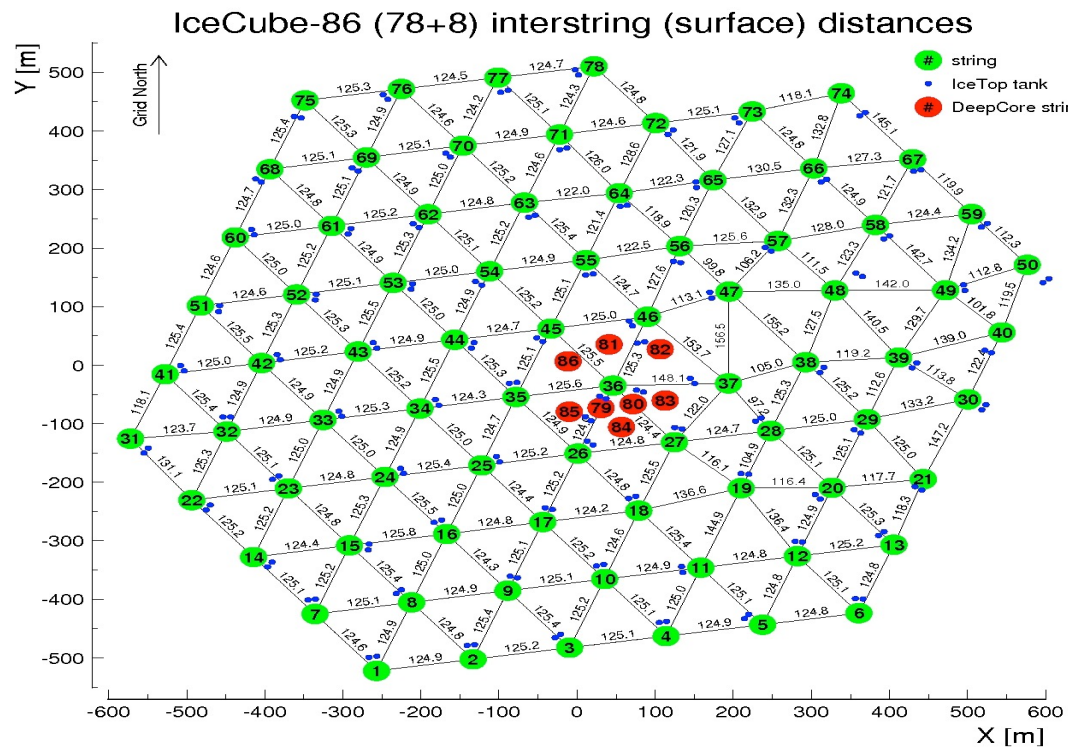

IceCube Digital Optical Module (DOM)

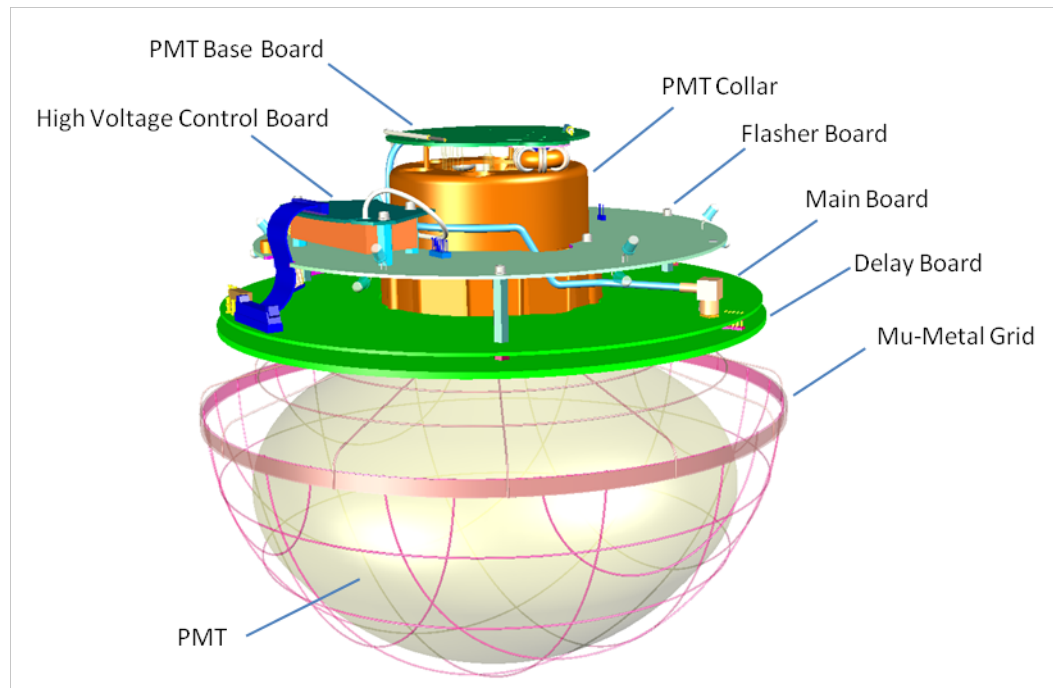

Every DOM in IceCube is equipped with flasher LEDs

This gives us a controlled light source at every location in the detector

Signal in a Photomultiplier Tube

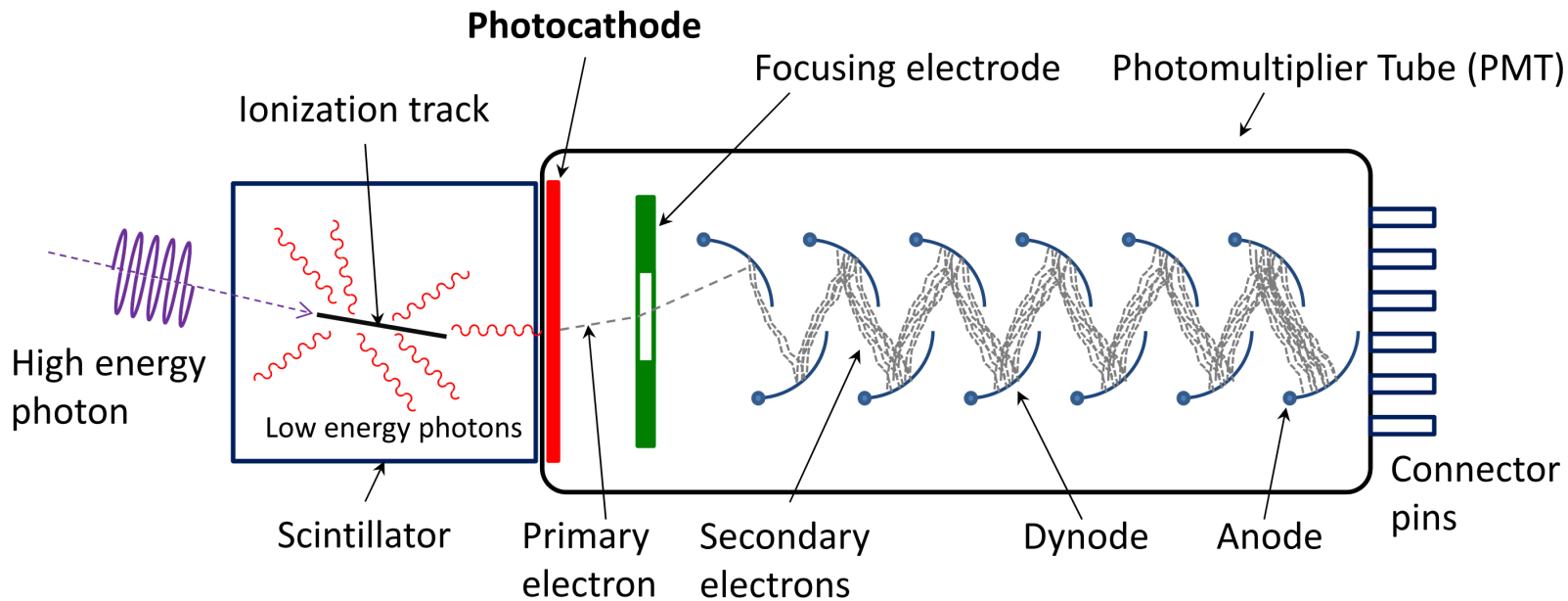
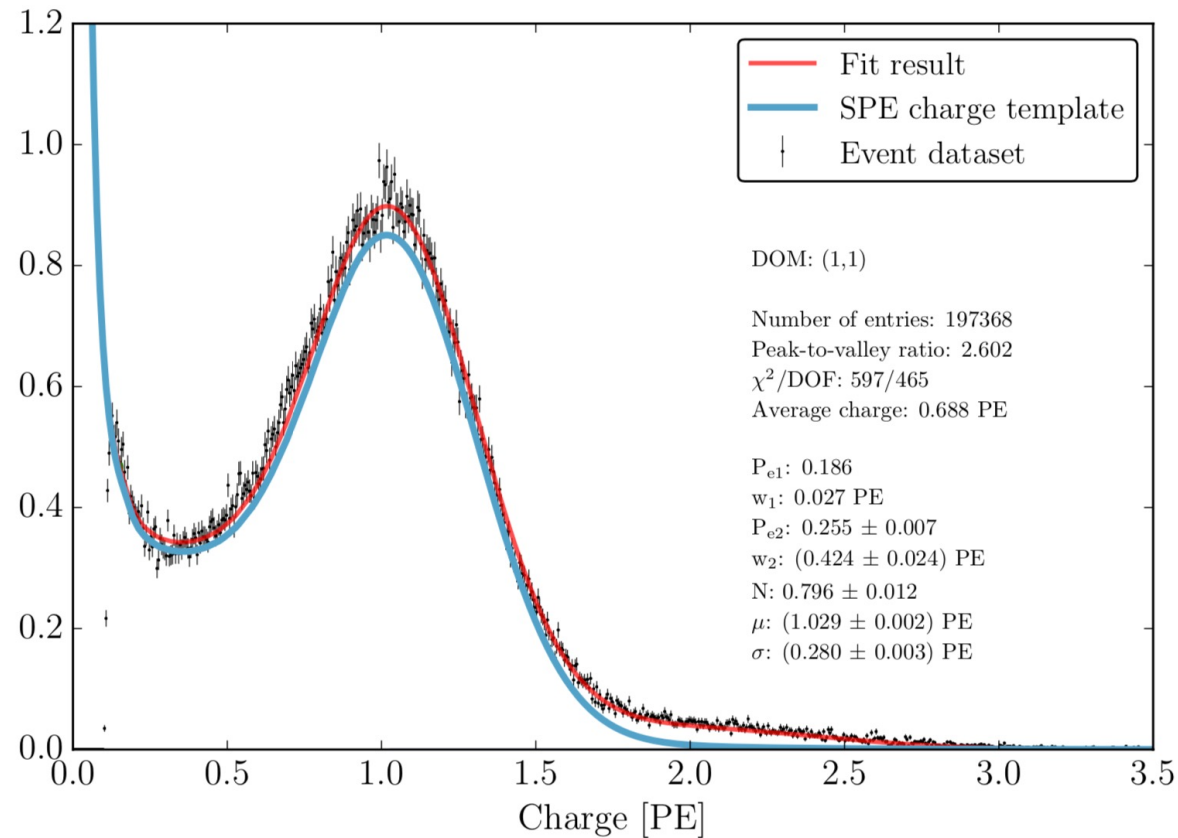

Table 1: Hamamatsu specifications for the R7081-02 PMT (typical)

Spectral response	300 to 650 nm
Quantum efficiency at 390 nm	25%
Supply voltage for gain 10^7	1500 V
Dark rate at -40°C	500 Hz
Transit time spread	3.2 ns
Peak to valley ratio for single photons	2.5
Pulse linearity at 2% deviation	70 mA

Single Photoelectron Charge Distribution



This is measured individually for every single DOM and forms the basis for energy calibration

From photon to charge distribution

- Amplification isn't exact, resulting in a distribution of charge from single PEs at photocathode

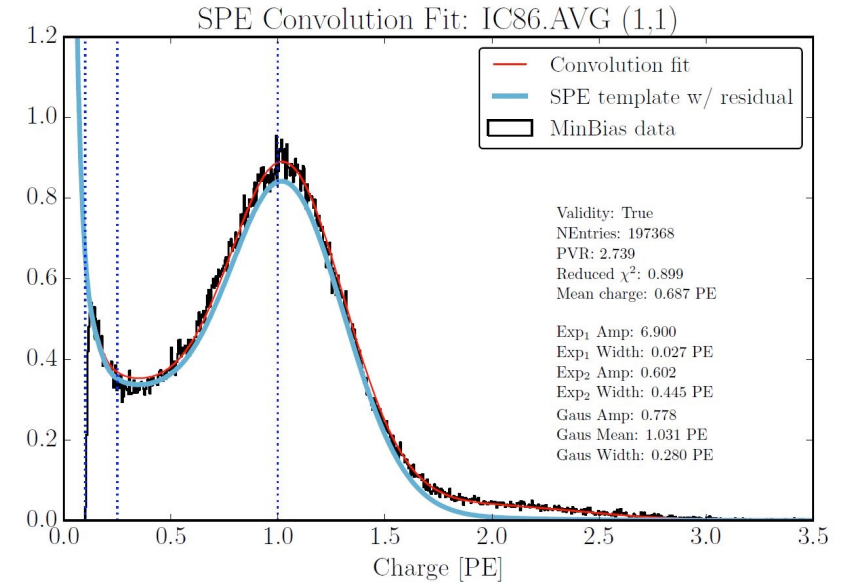

The single photoelectron (SPE) templates represent the probability density function for the charge distributions on all in-ice DOMs. The functional form used to describe the distribution is the sum of two exponentials and a Gaussian, $\text{Exp}_1 + \text{Exp}_2 + \text{Gauss.}$, explicitly:

$$f(q)_{\text{SPE}} = \frac{P_{e1}}{w_1} \cdot e^{-q/w_1} + \frac{P_{e2}}{w_2} \cdot e^{-q/w_2} + \frac{1 - P_{e1} - P_{e2}}{\sigma \sqrt{\pi/2} \cdot \text{Erfc}[-\mu/(\sigma \sqrt{2})]} \cdot e^{-\frac{(q-\mu)^2}{2\sigma^2}}$$

From photon to charge distribution

- Electrons arrive at anode over several nanoseconds ("jitter"/"TTS")

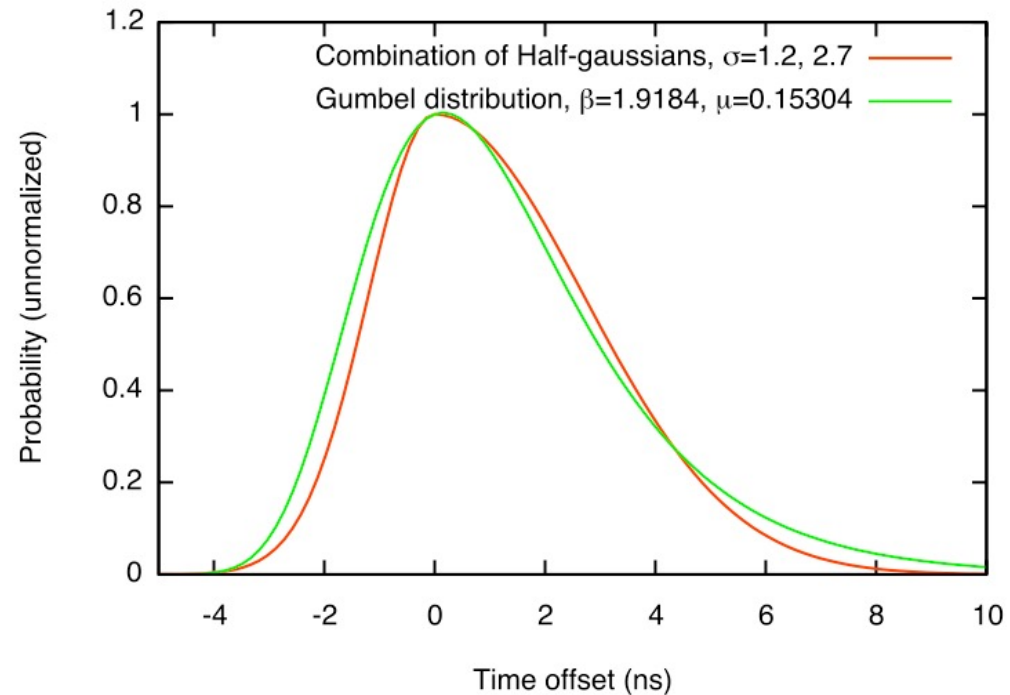

From photon to charge distribution

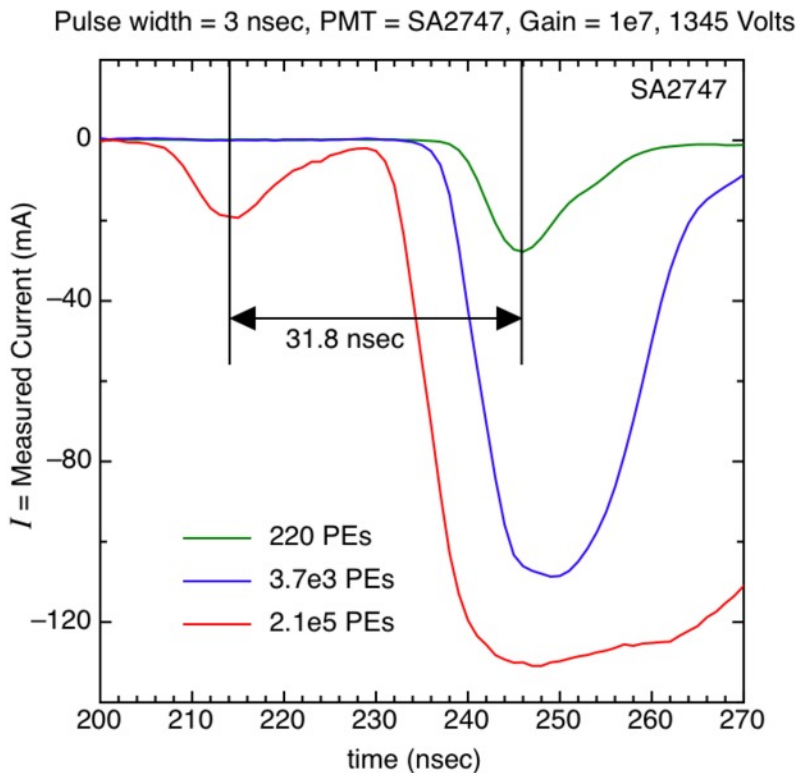

- **Pre-pulses:** result of photons striking first dynode instead of photocathode
- Late pulses: result of photoelectrons backscattered off the first dynode
- Afterpulses: result of ions created near the last dynode that accelerate back to the photocathode and produce multiple photoelectrons

From photon to charge distribution

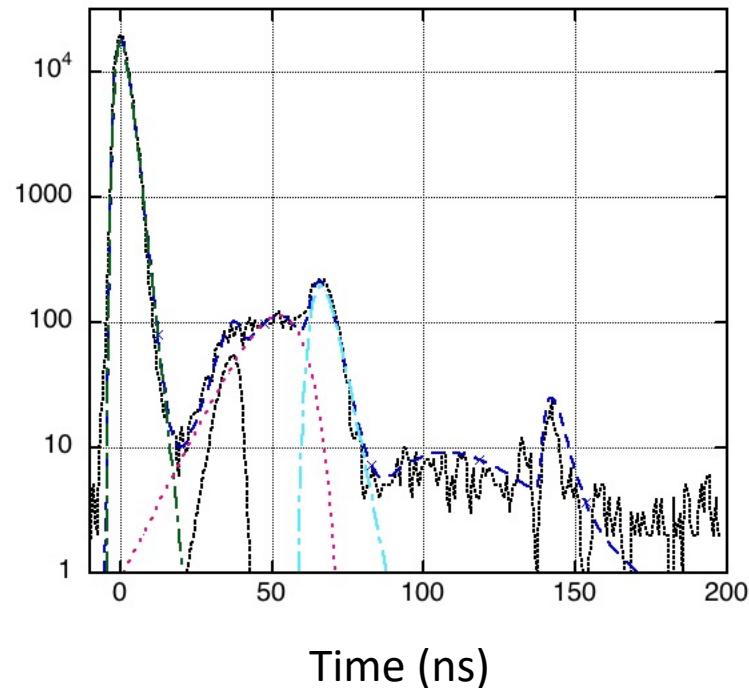

- Pre-pulses: result of photons striking first dynode instead of photocathode
- **Late pulses: result of photoelectrodes backscattered off the first dynode**
- Afterpulses: result of ions created near the last dynode that accelerate back to the photocathode and produce multiple photoelectrons

From photon to charge distribution

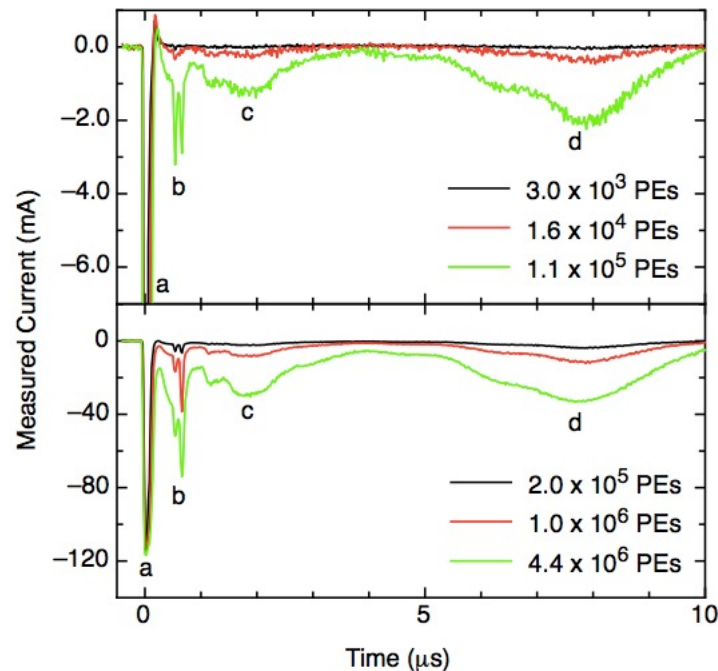

- Pre-pulses: result of photons striking first dynode instead of photocathode
- Late pulses: result of photoelectrodes backscattered off the first dynode
- **Afterpulses: result of ions created near the last dynode that accelerate back to the photocathode and produce multiple photoelectrons**

From photon to charge distribution

- At some point, the PMT "saturates", meaning adding more PEs no longer adds more observed charge

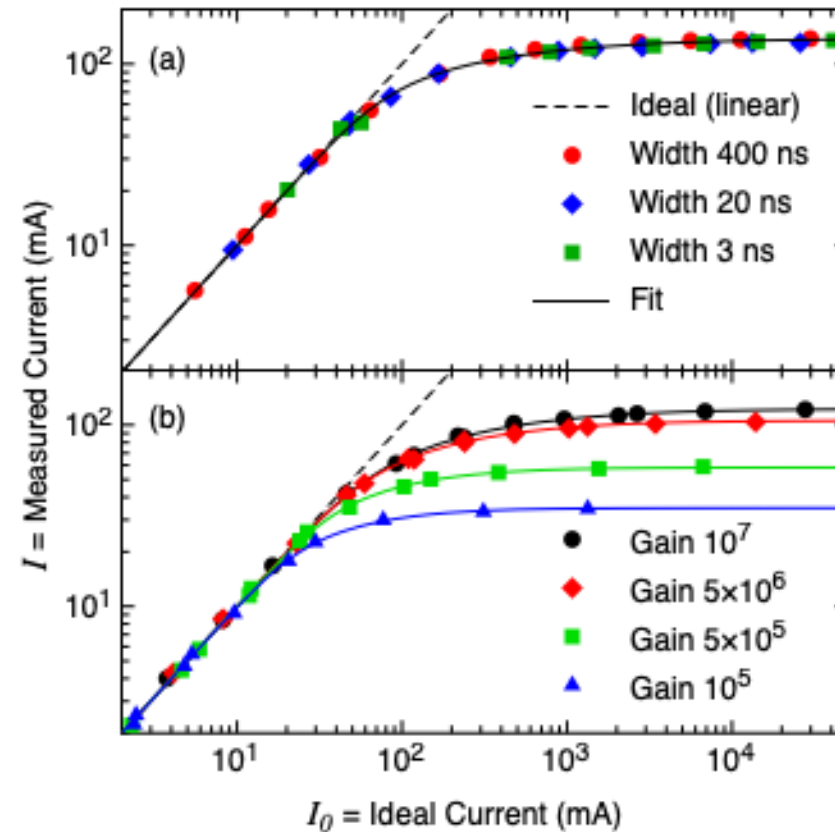

DOM Output: single photoelectron

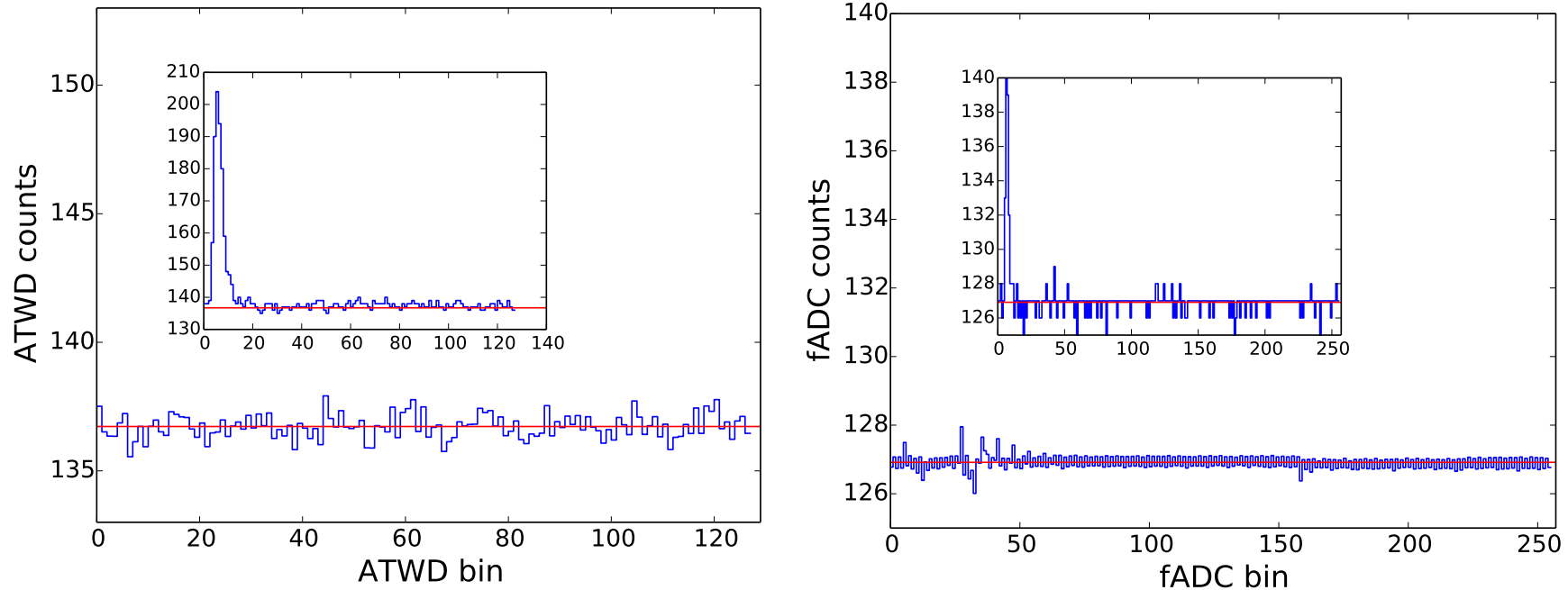

This is what we record when light hits the DOM: a waveform

DOM output: complex waveform

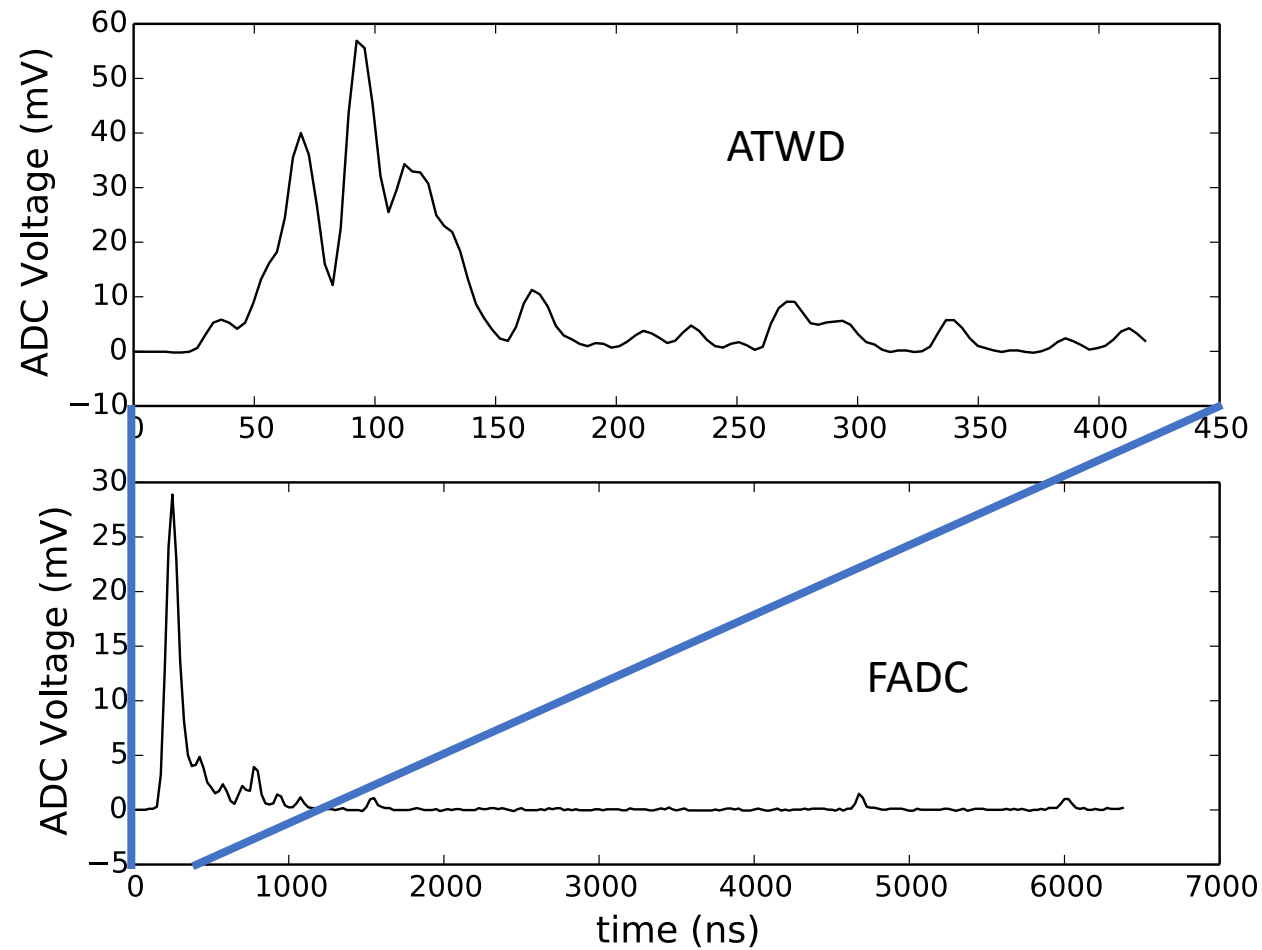

Waveforms to pulses

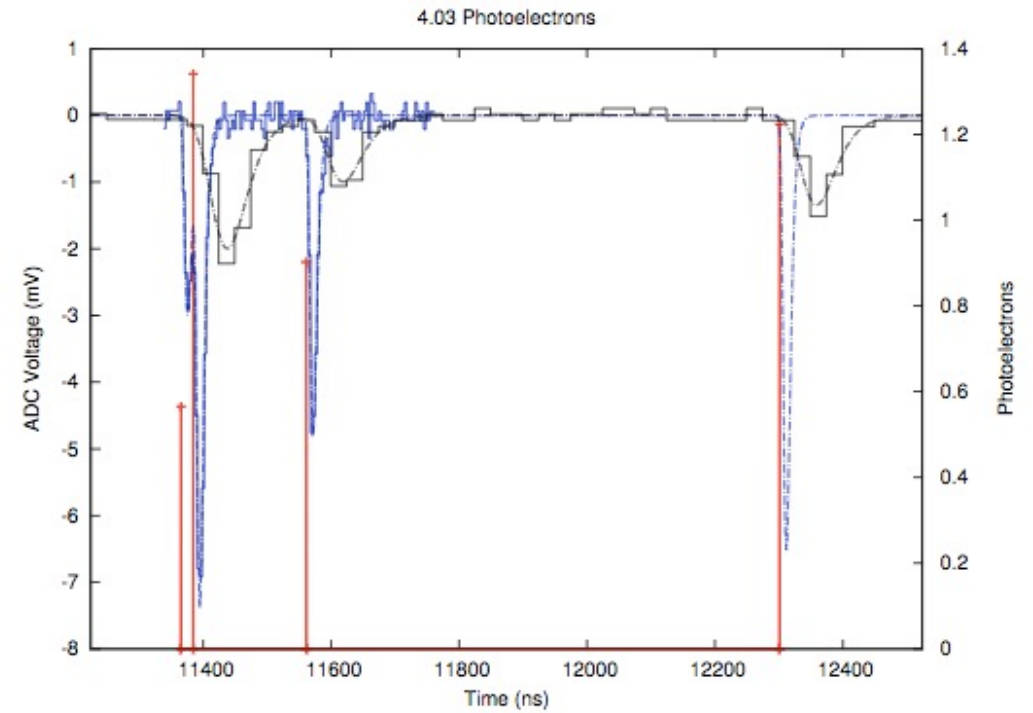
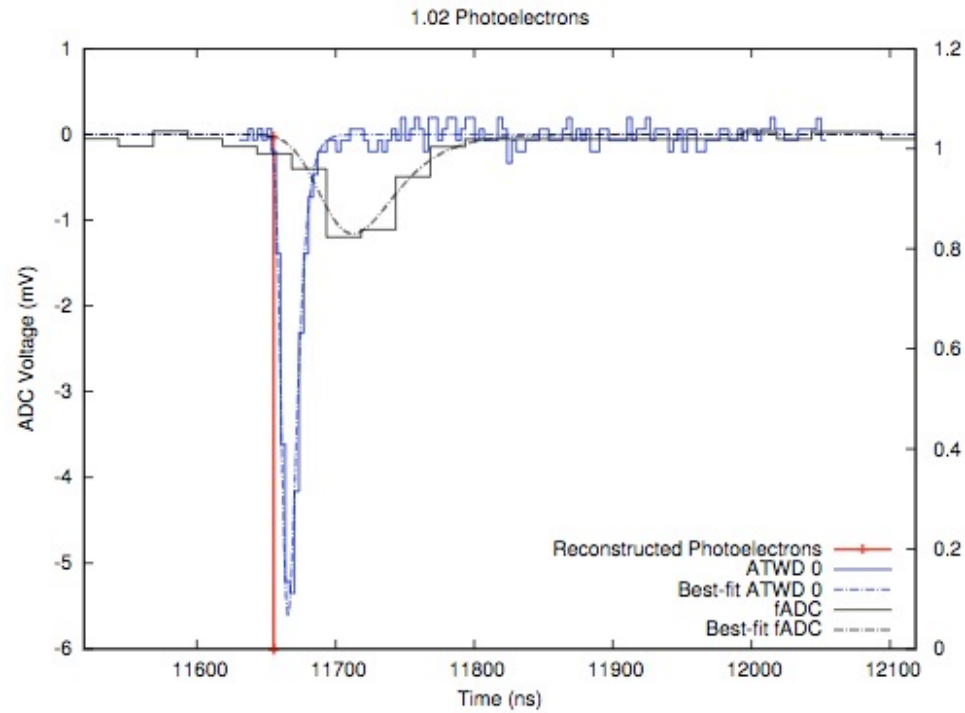

Noise

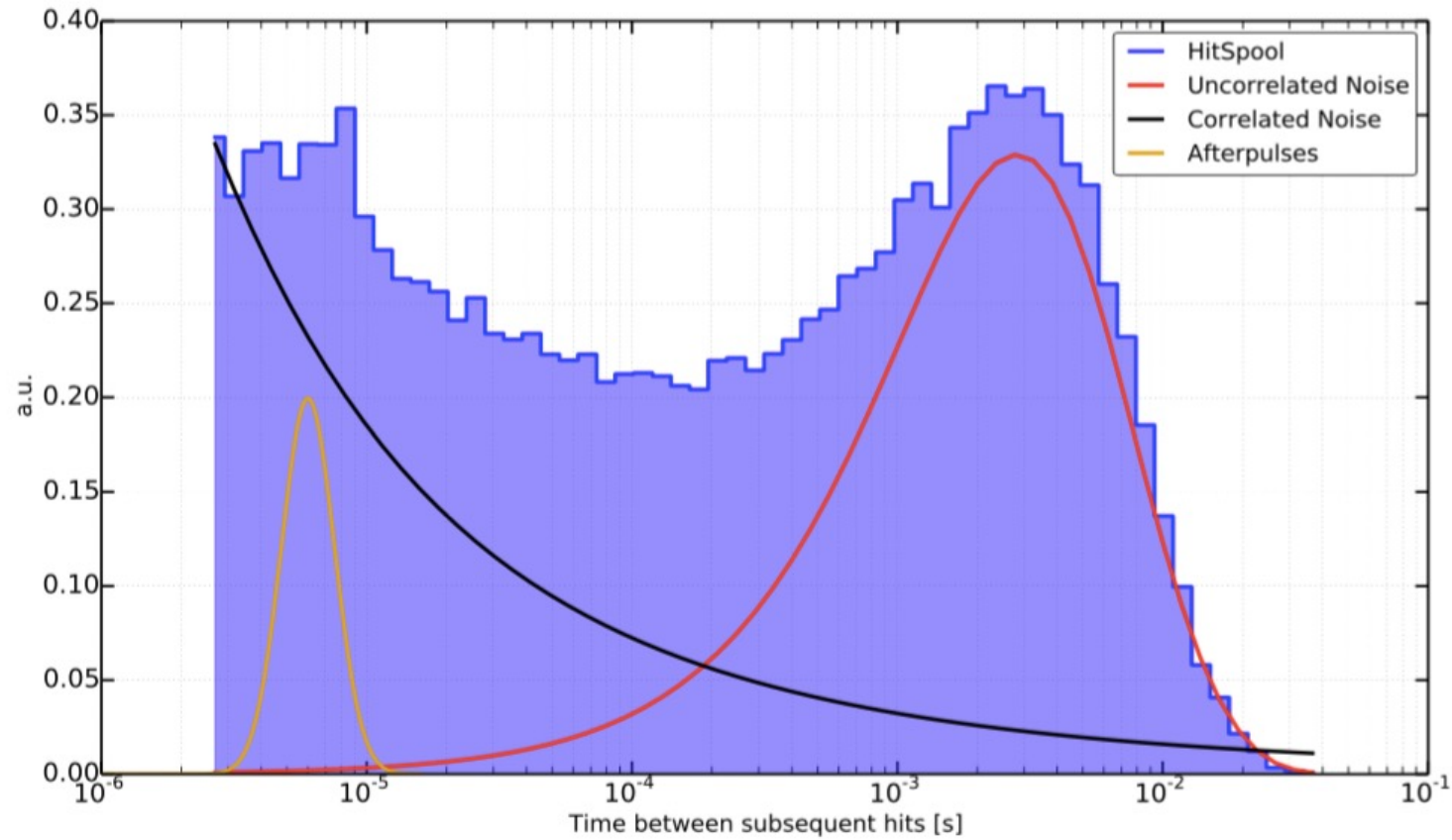

Distribution of time between hits for noise events – important for low energy events

An IceCube neutrino (“Big Bird”)

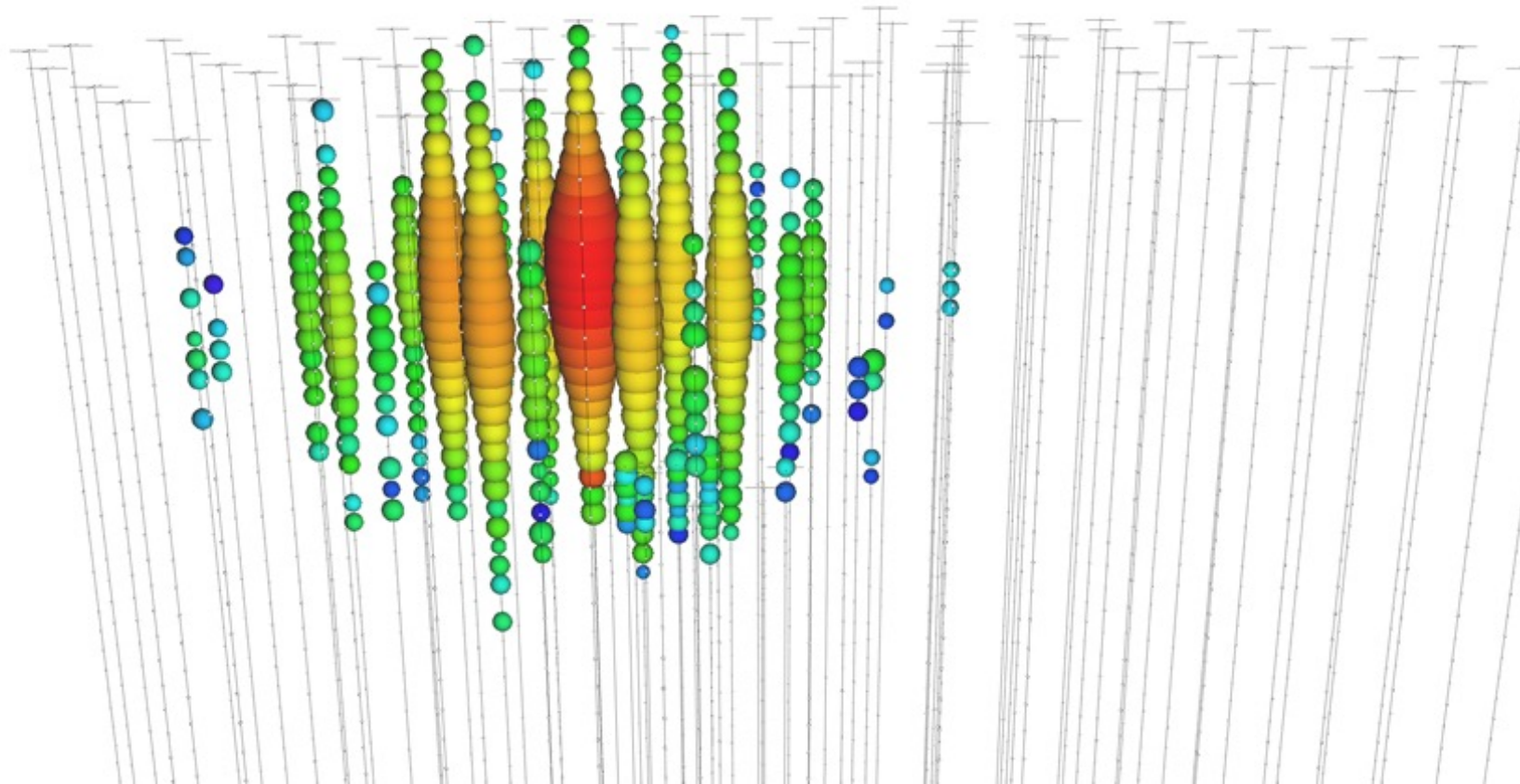

How do we know how much energy Big Bird has?

How do we know where it comes from?

The ideal picture

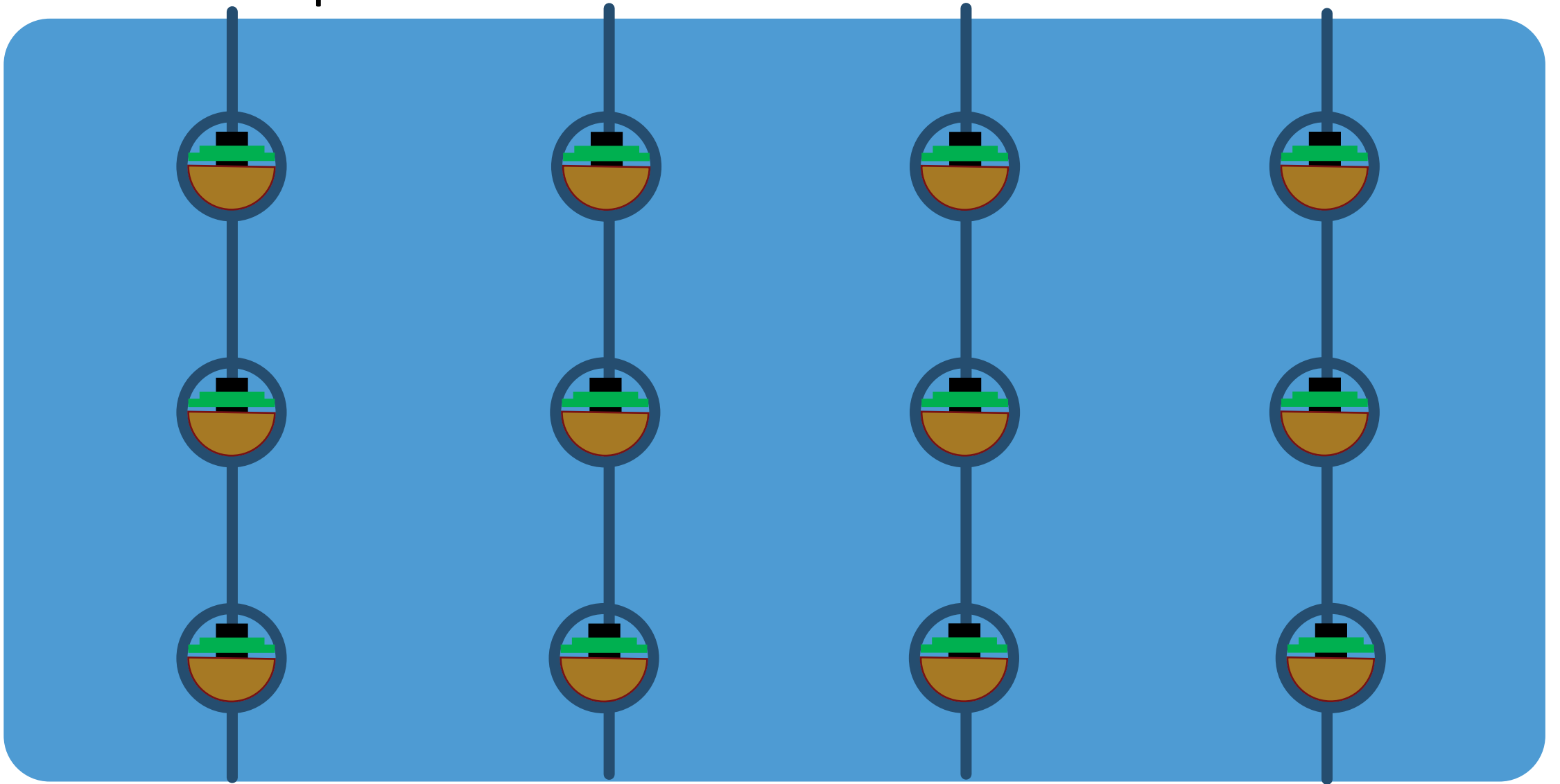

The ideal picture

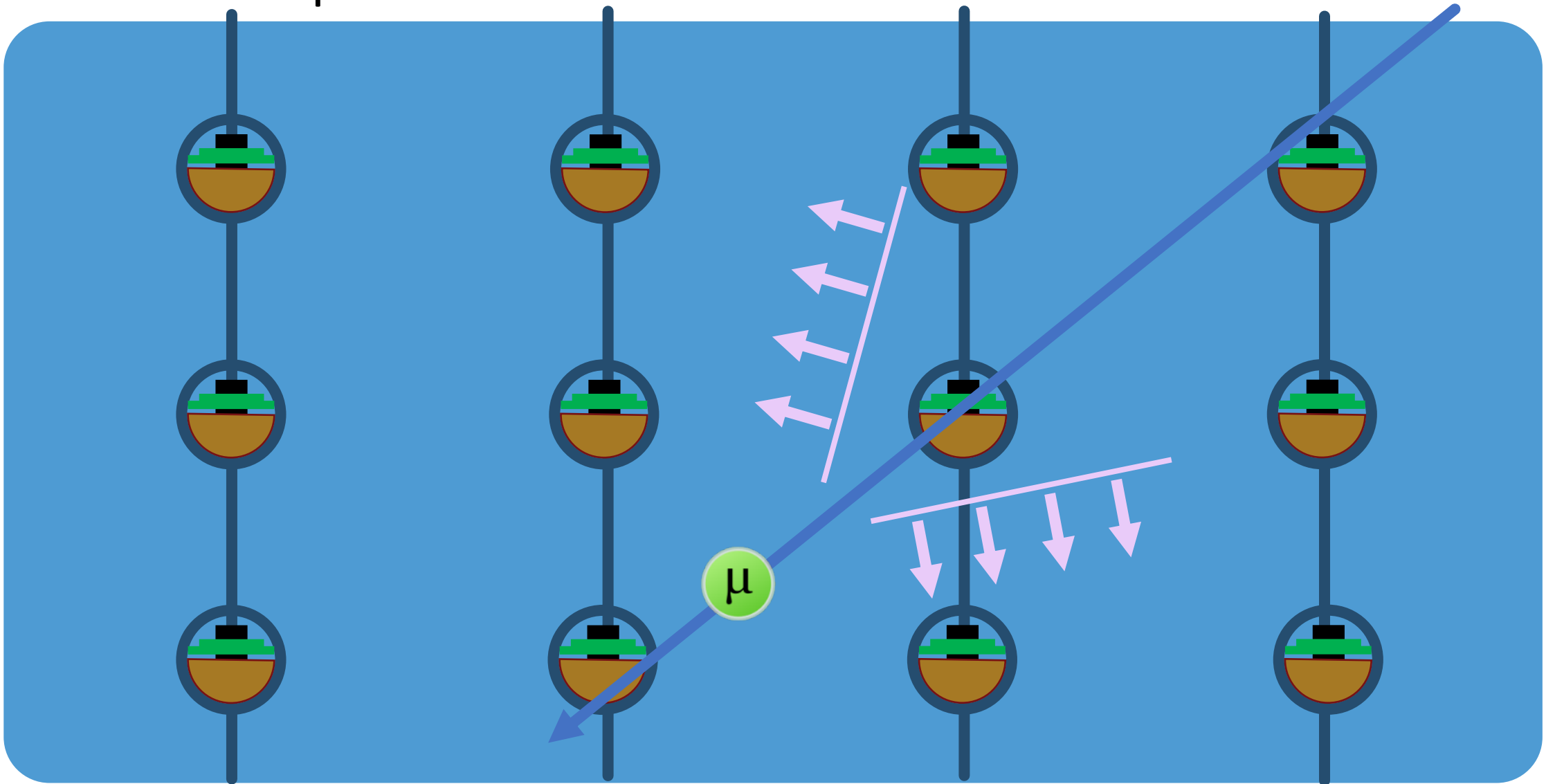

The ideal picture

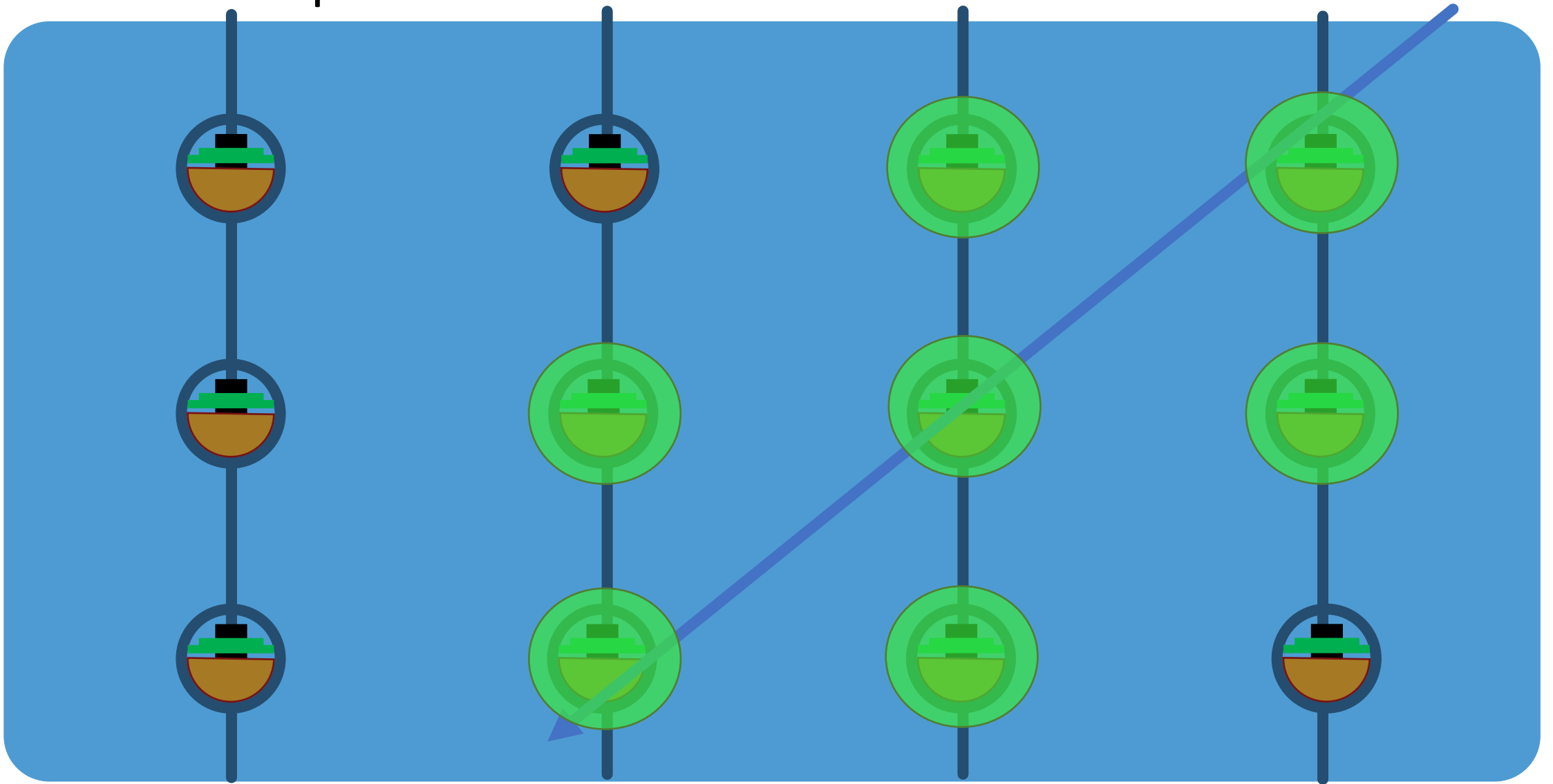

The ice model

- The ice is as much a part of the detector as the DOMs!
- The ice is our calorimeter, support structure and shielding
- For a complete history of the ice model see here
https://wiki.icecube.wisc.edu/index.php/Ice_models

Calibration: from photon to data

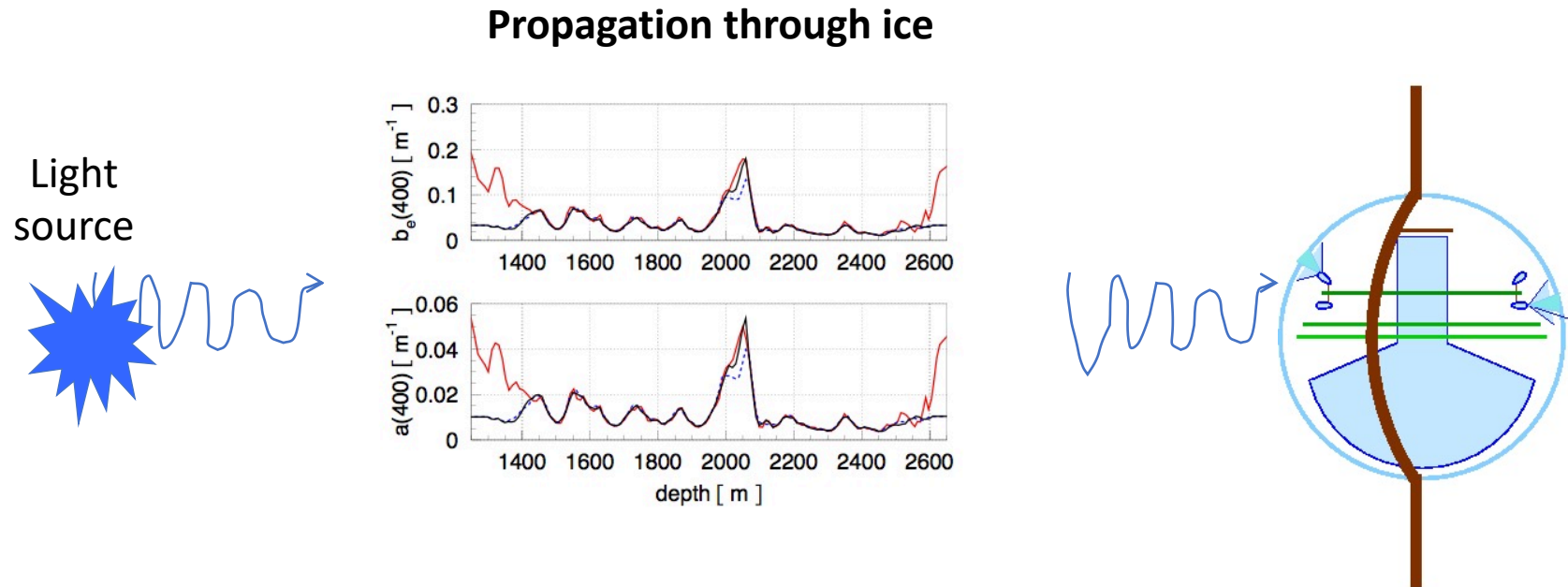

We need to know how light propagates in ice.
Major propagation processes are **absorption** and **scattering**

Ice vs. water

- This type of experiment can be done in water (DUMAND, ANTARES/NEMO/NESTOR → KM3NET, Baikal → GVD) or ice (AMANDA → IceCube)
- Water has good scattering properties, poor absorption properties
- Ice has good absorption properties, poor scattering properties
- Scattering affects direction, absorption affects energy
- Ice has practical advantages over water for detector construction, IceCube was the first cubic kilometer neutrino detector

Effect of Scattering in Ice

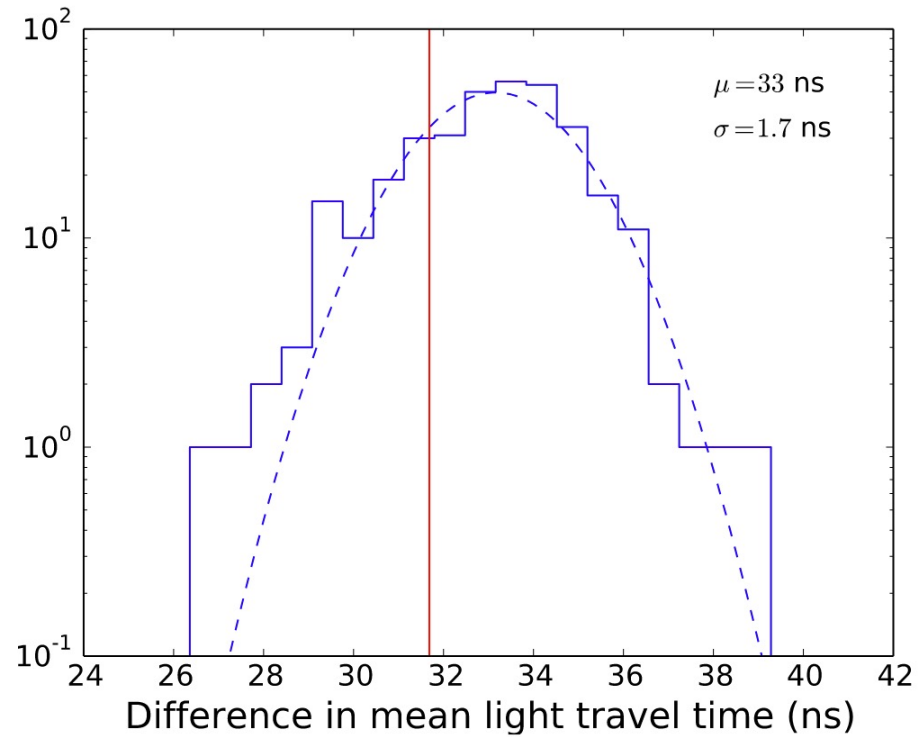
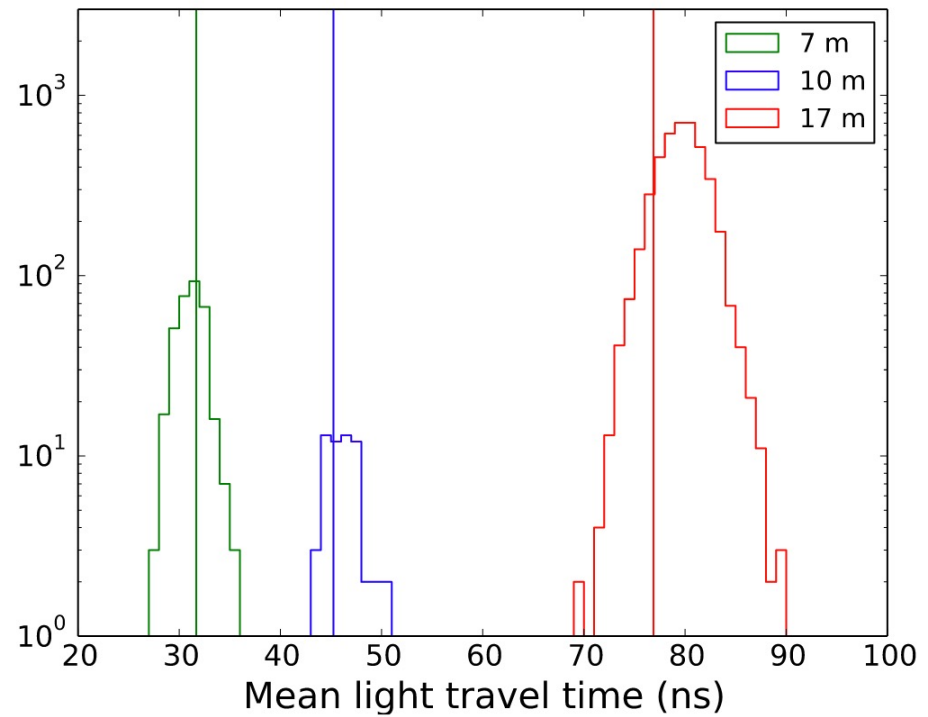

Light arrives later than it should.

Effect of scattering in ice (toy simulation of tau double pulse waveform)

No scattering

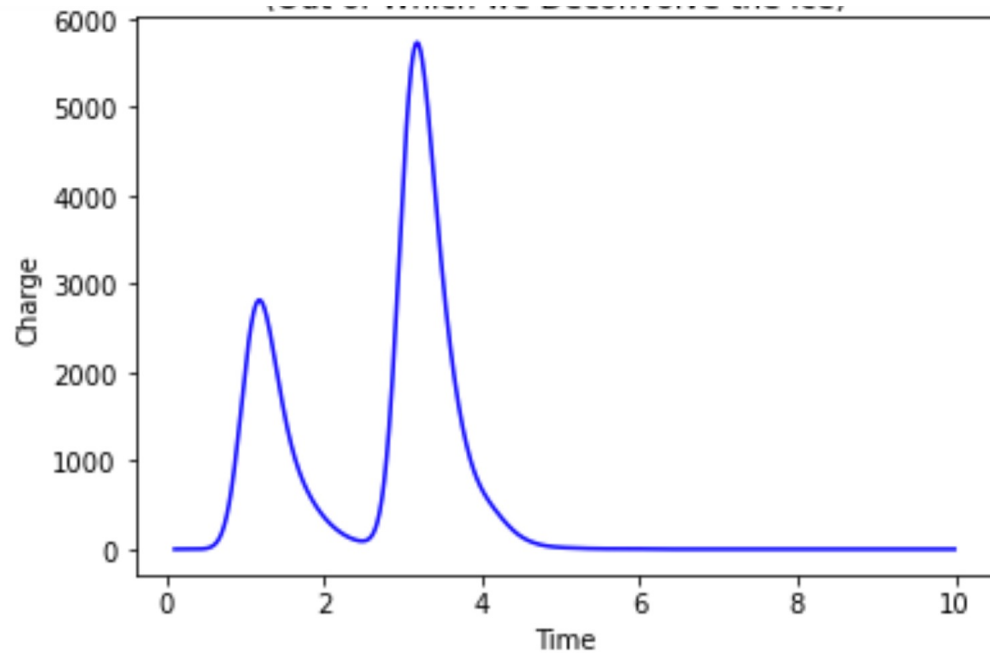

Scattering

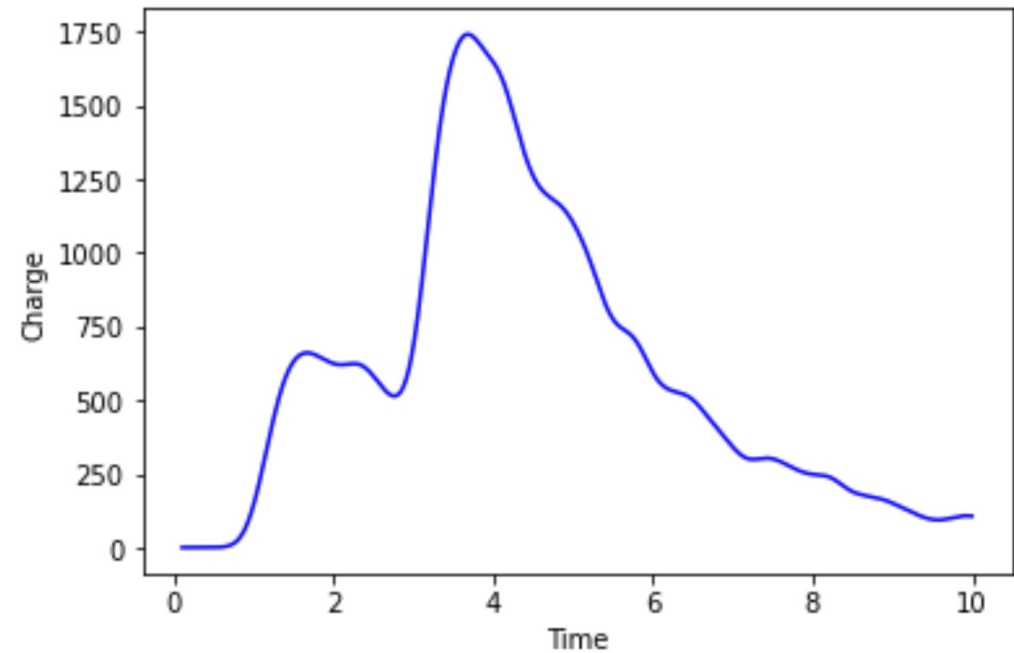

The ice is complex...

- No bubbles in undisturbed ice at IceCube depths (craigite/clathrates)
- Layers of dust cause depth-dependent scattering and absorption
- The dust layers are not horizontal...
- And the scattering is anisotropic...
- And the melted and refrozen ice in the holes has a bubble column in the center...

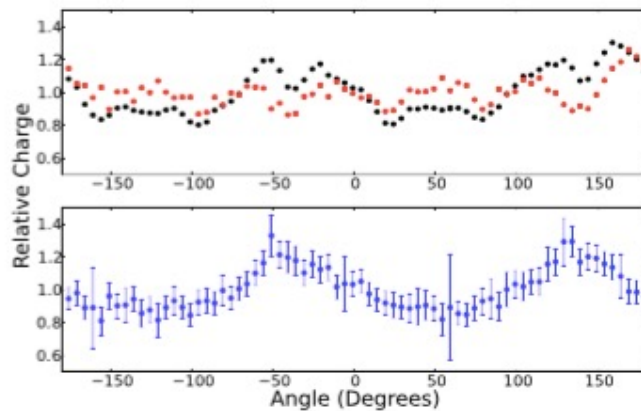
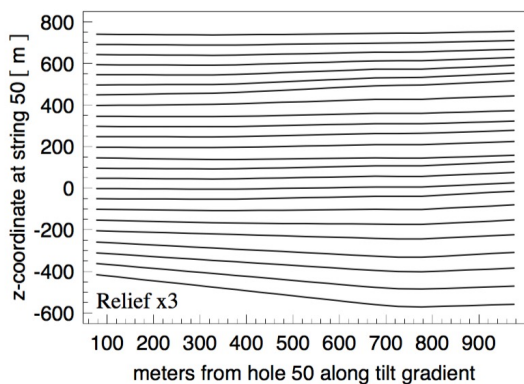
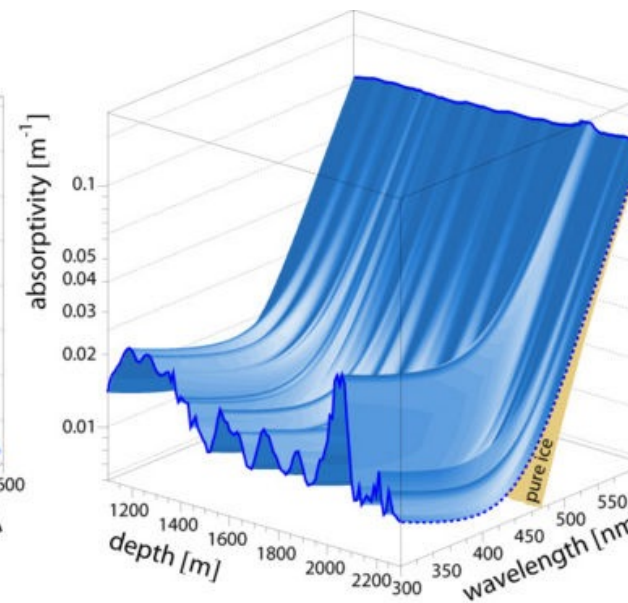
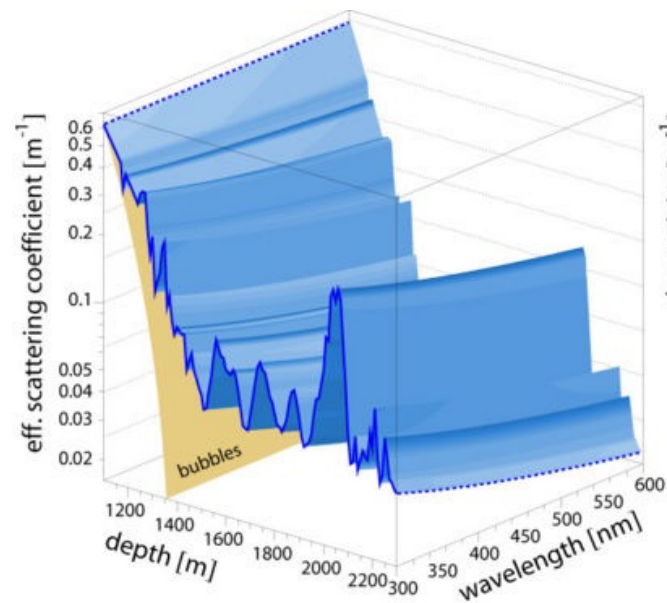

What causes scattering in ice?

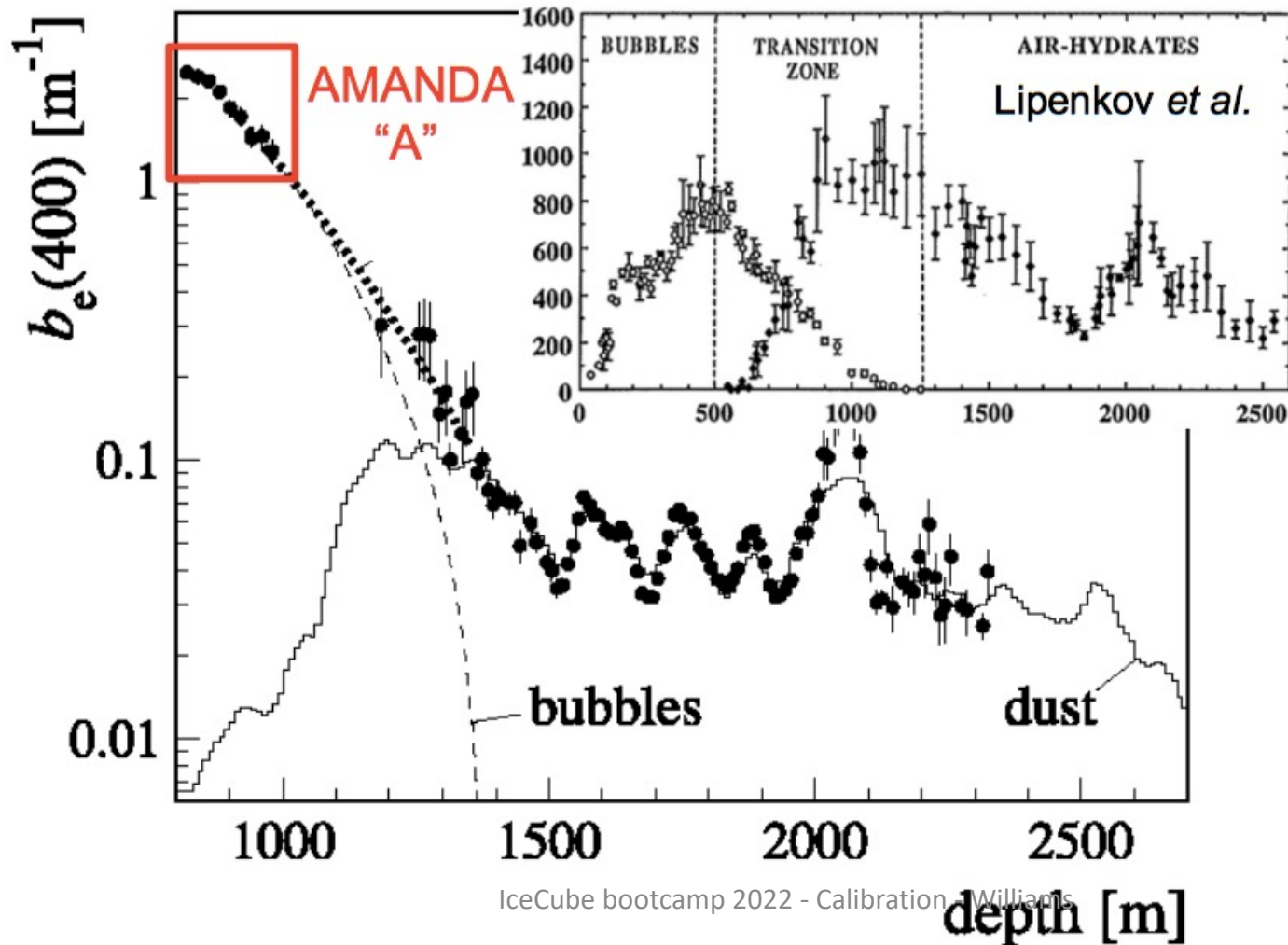

Multiple dust layers, an especially thick layer at about 2000 m depth is called “THE dust layer” in IceCube vernacular

Ryan Bay

Why not Greenland? Ask the IceCube DustLogger

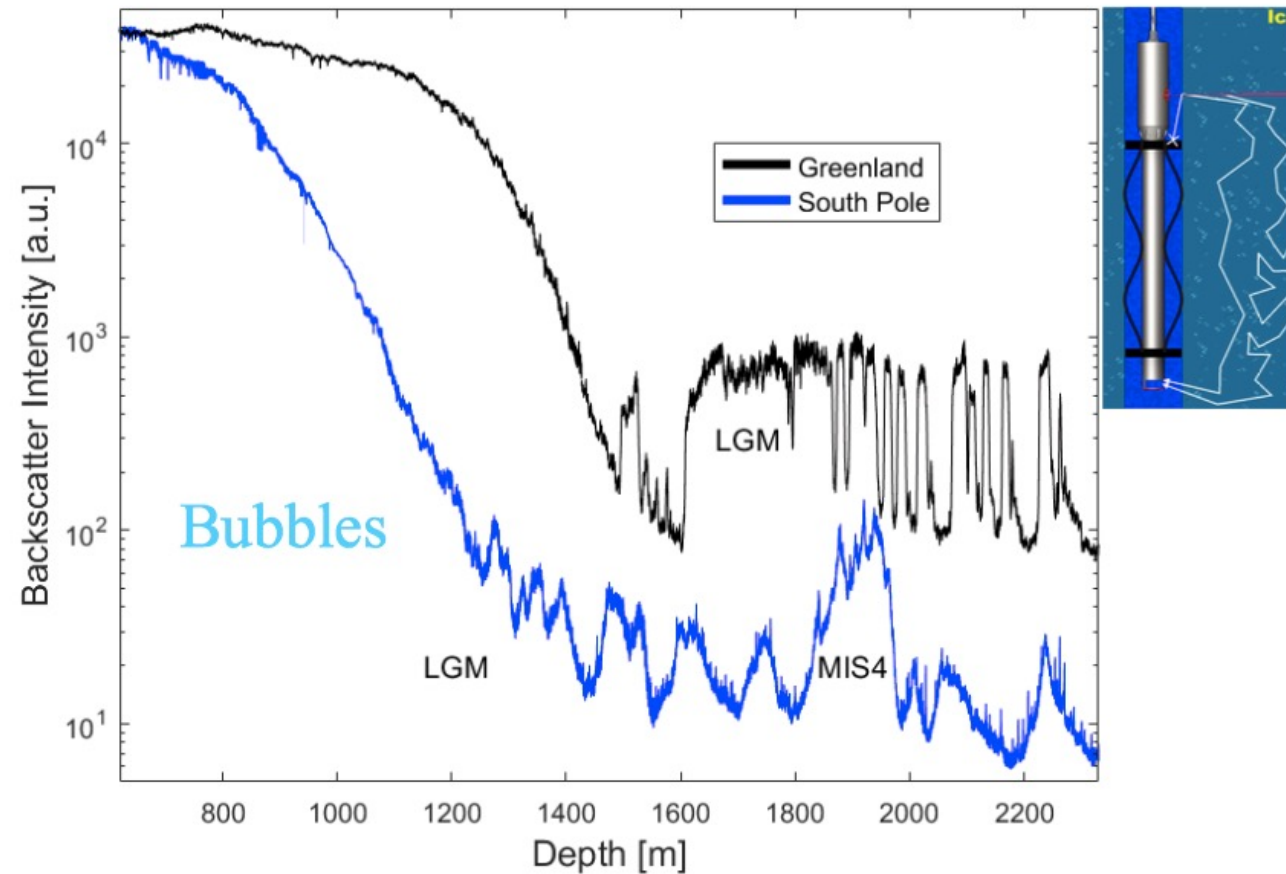

LGM = Last Glacial
Maximum, 26.5 kya

MIS4 = Marine Isotope
Stage 4, 71 kya

Ryan Bay

IceCube events and “The Dust Layer”

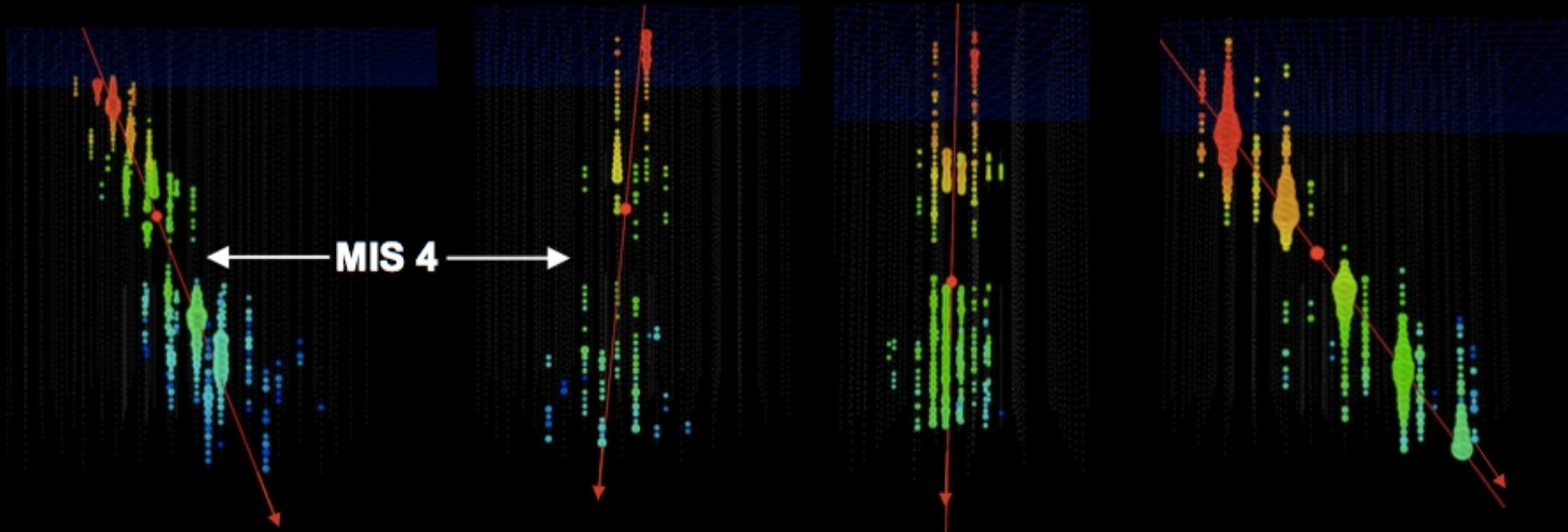

Effects of the dust layer: IC-190331

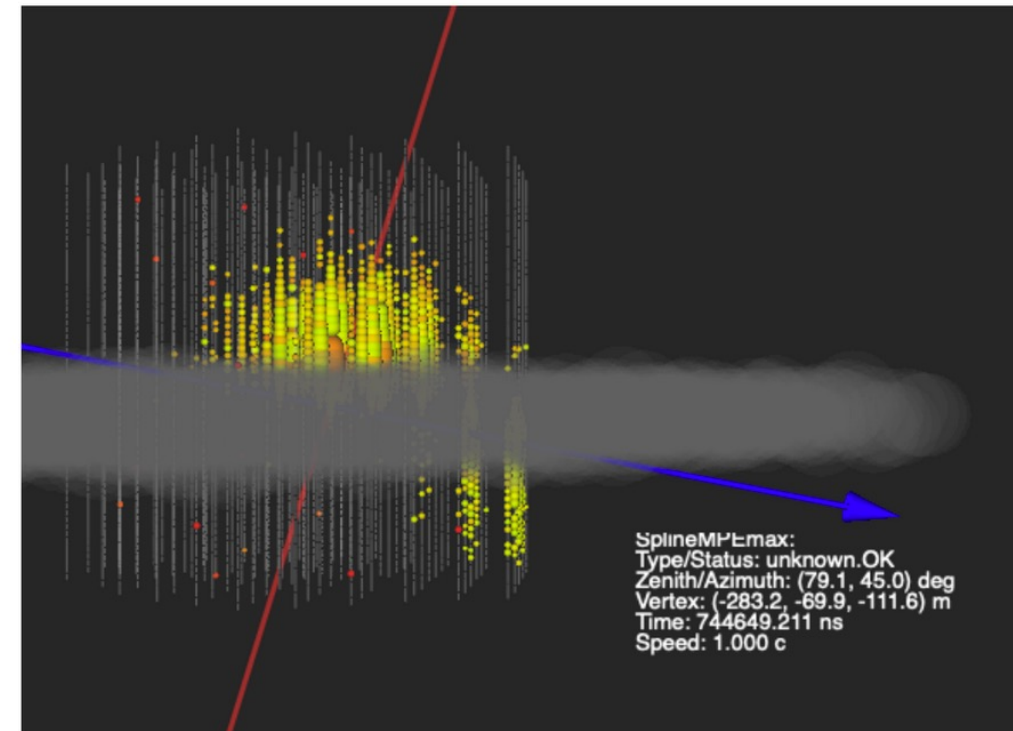
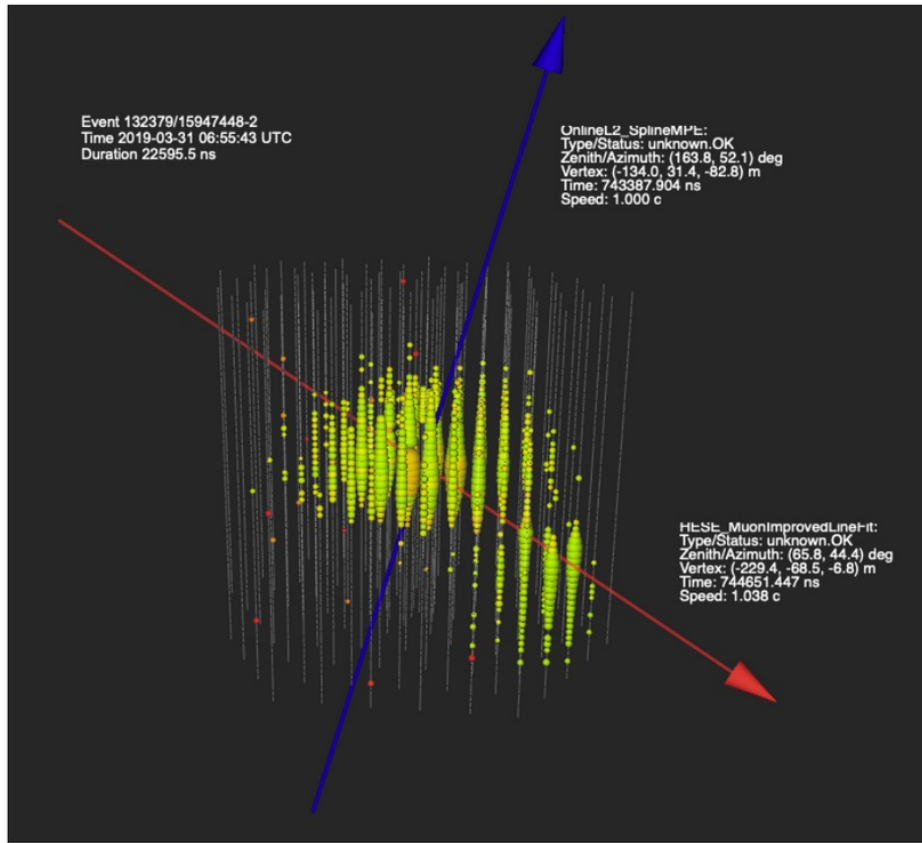

Thomas Kintscher

Absorption in South Pole Ice

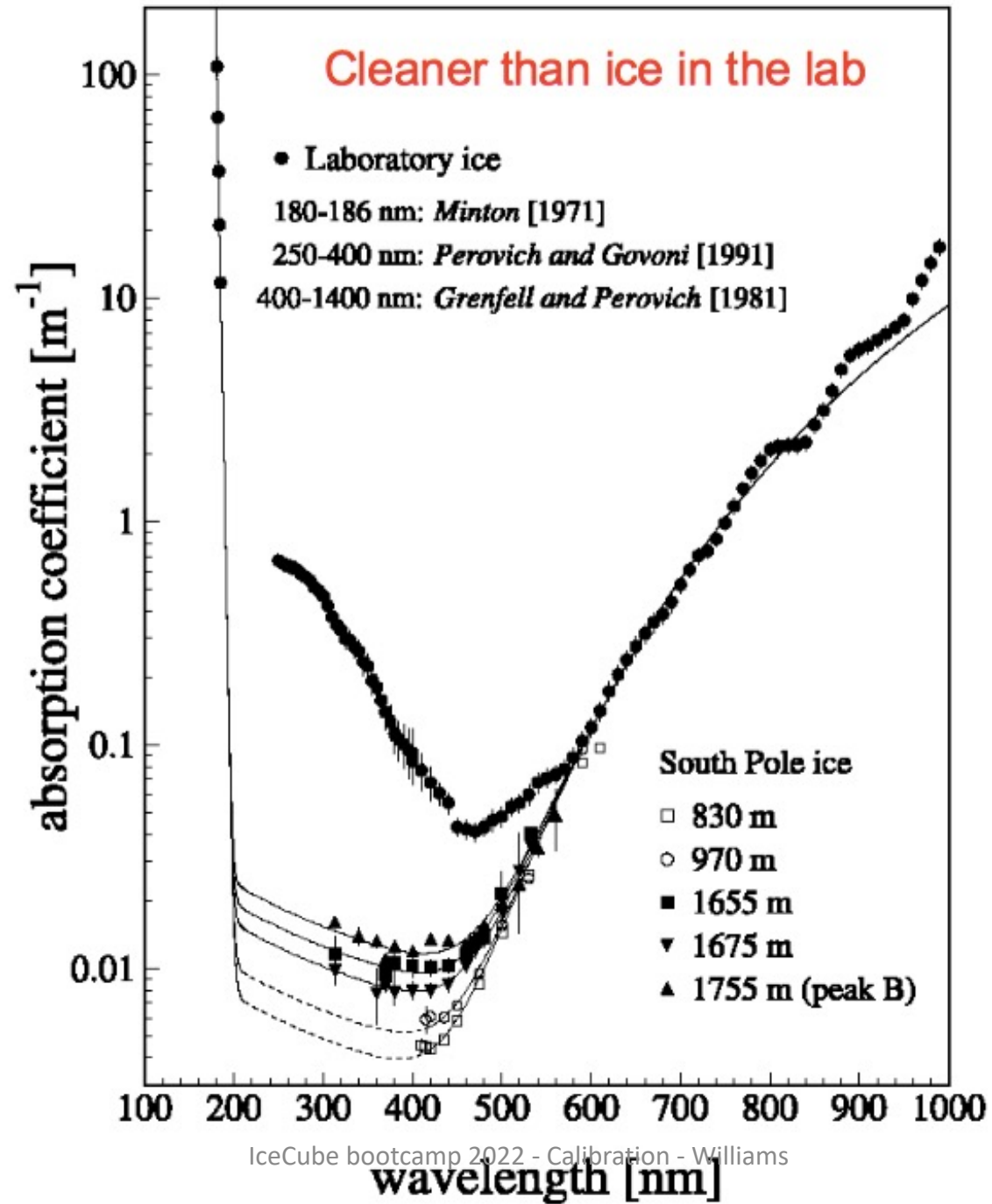

Ryan Bay

Ice flow in Antarctica

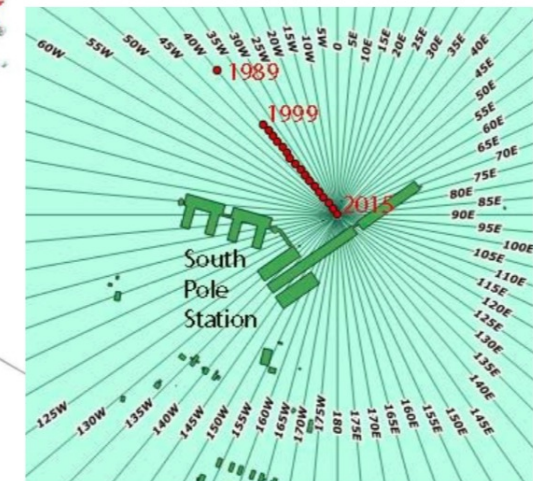
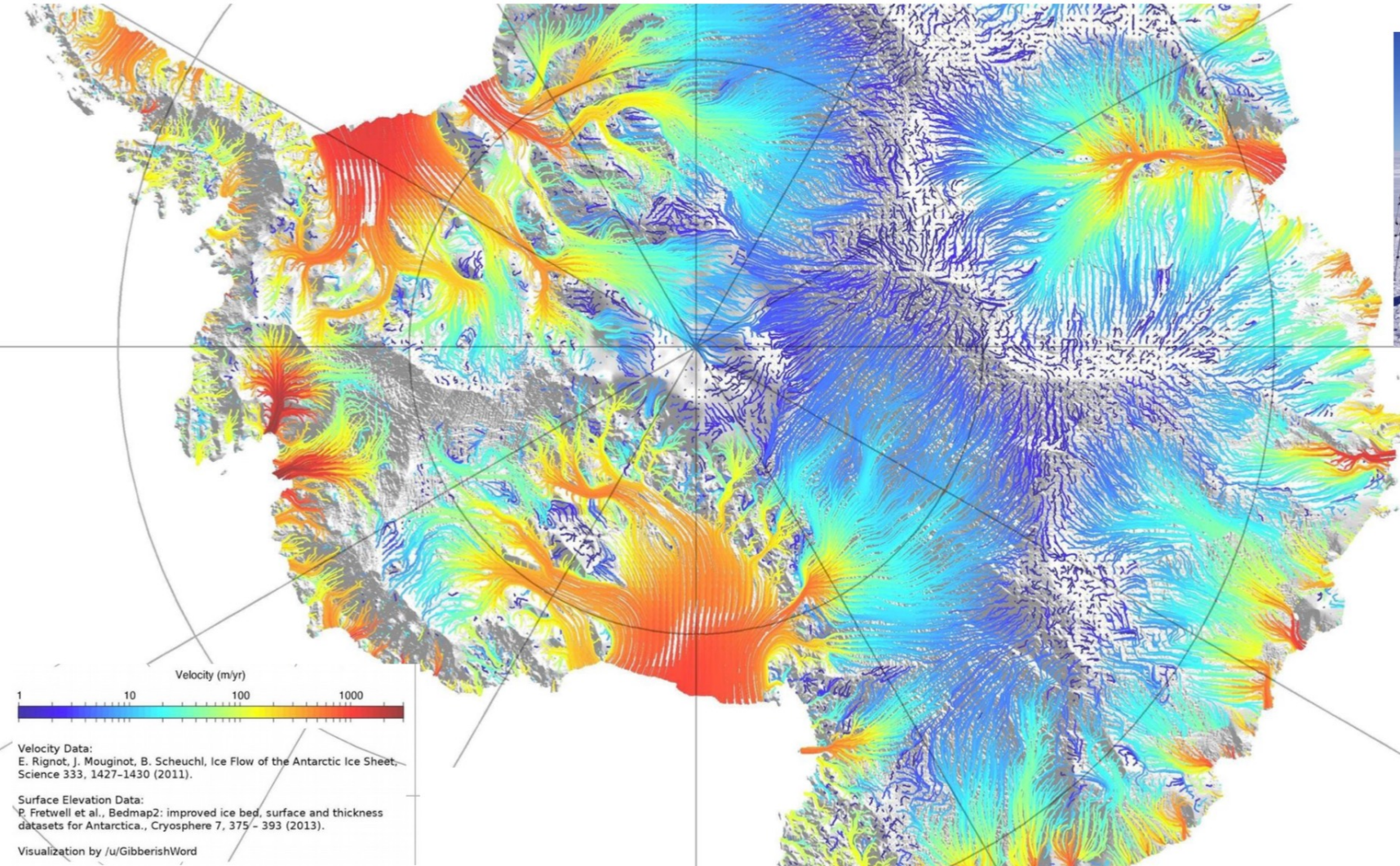

Dust layer tilt at the Pole

Up to 10% grade (100 m per lateral kilometer across IceCube)

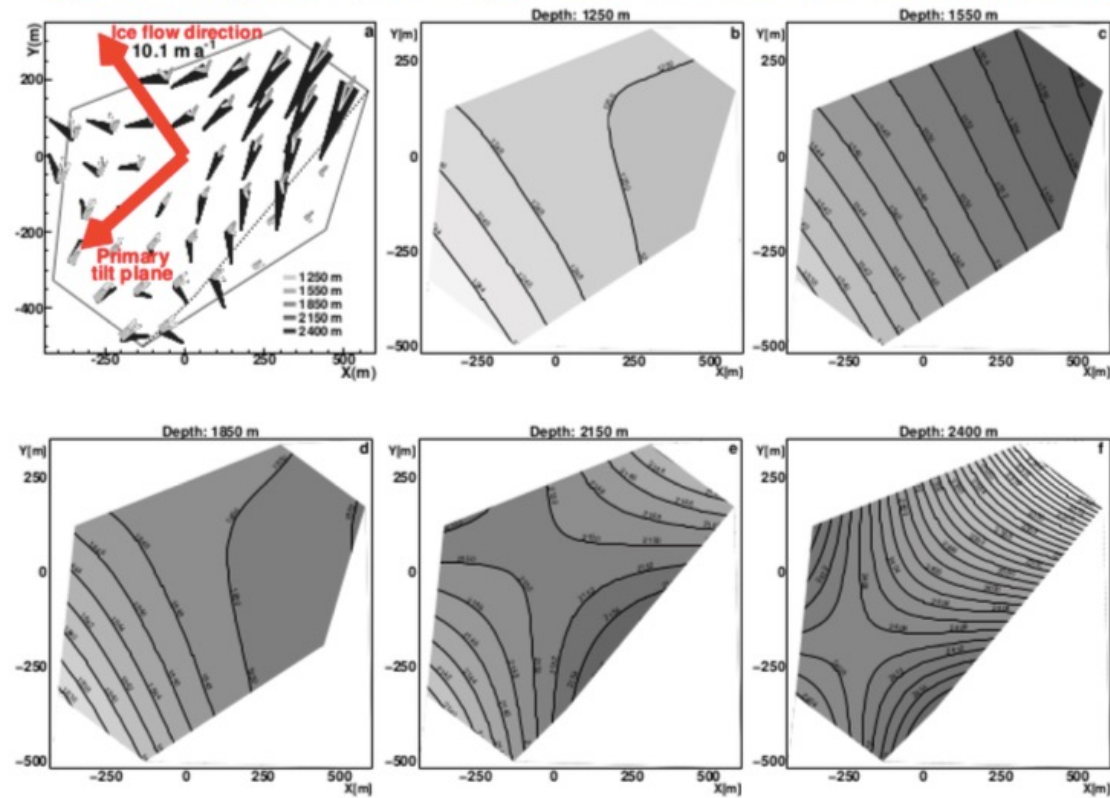

Ryan Bay

Why not drill deeper? Is shear a problem?

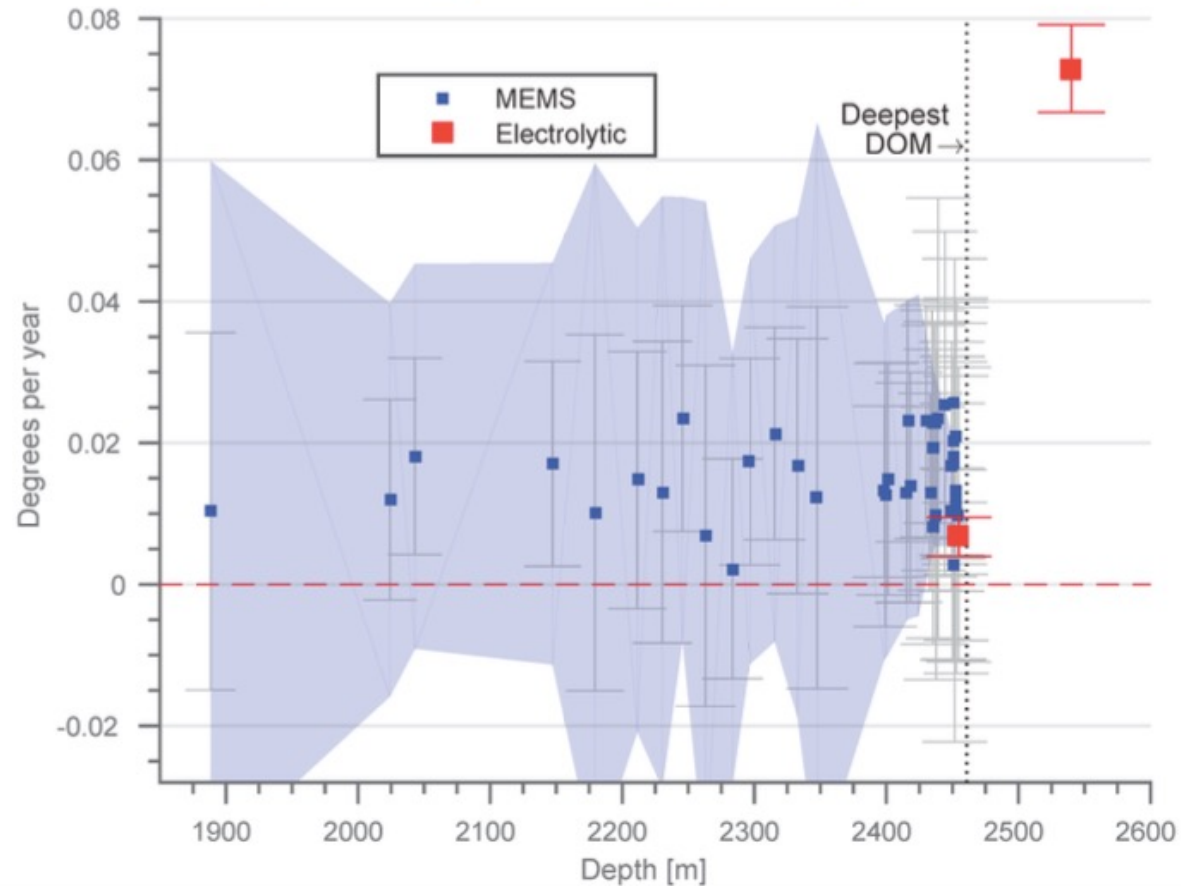

Ryan Bay

The hole ice

Current picture of hole ice

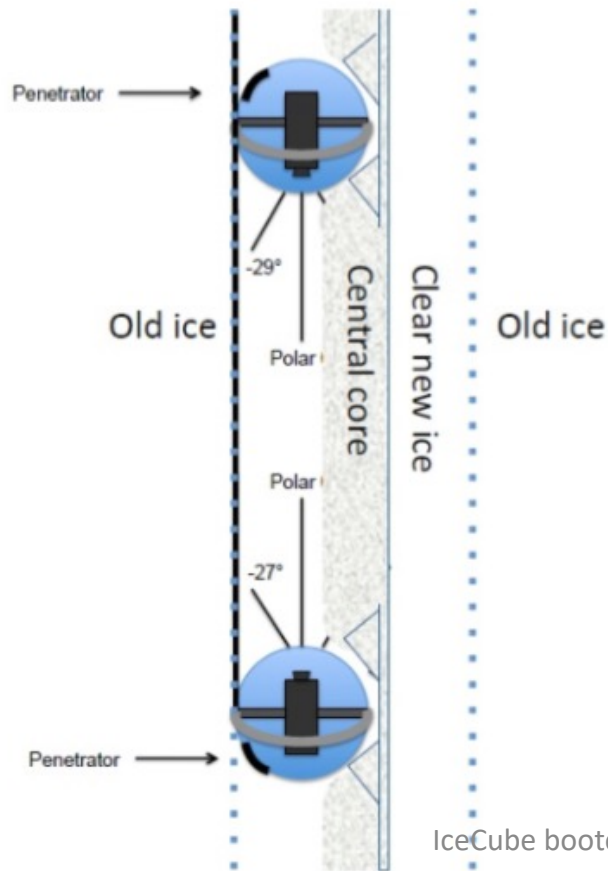

Some DOMs are less equal than others because of local effects in the hole ice.

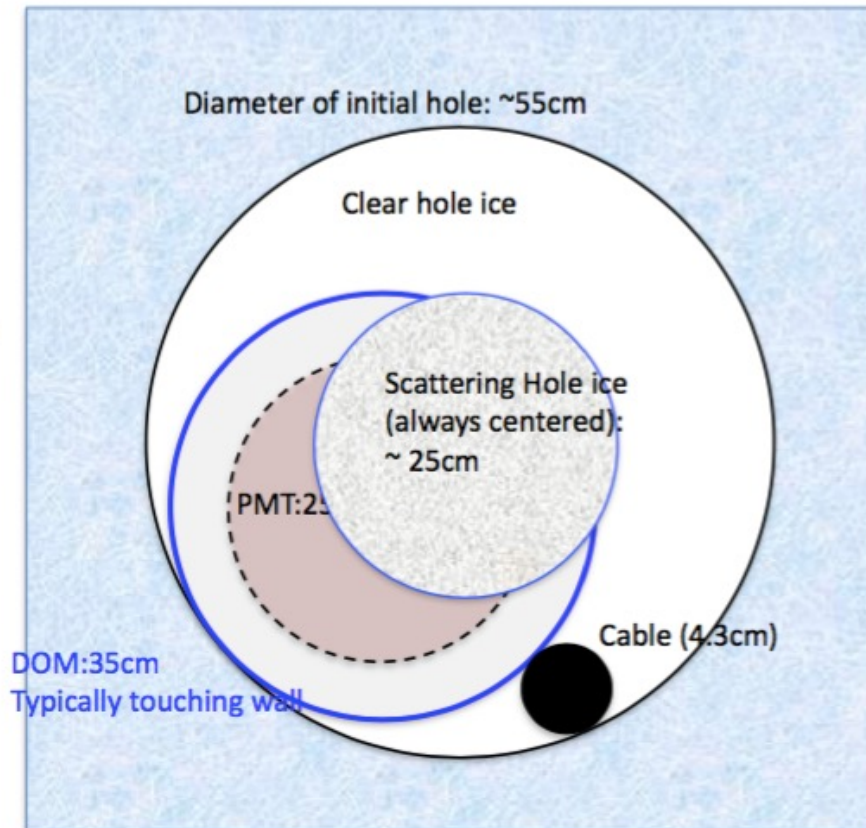

Albrecht Karle

29/12/10 (d/m/yr)

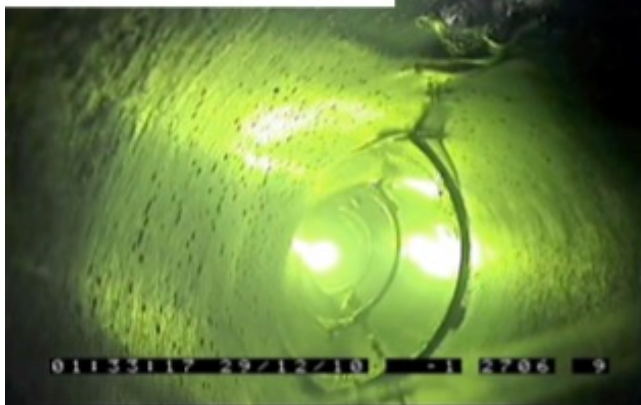

30/12/10



31/12/10

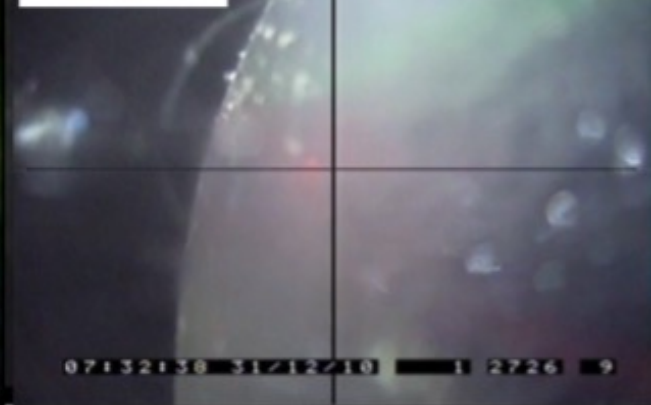

1/1/11

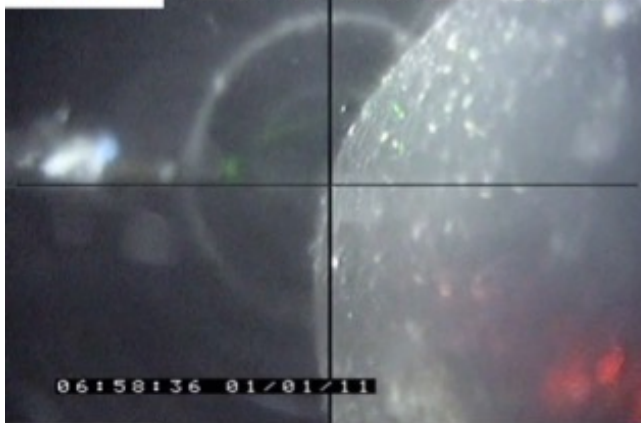

2/1/11



10/2/11



4/3/11



8/4/11



9/11/11



6/15/21

IceCube bootcamp 2022 - Calibration - Williams

10

Anisotropy

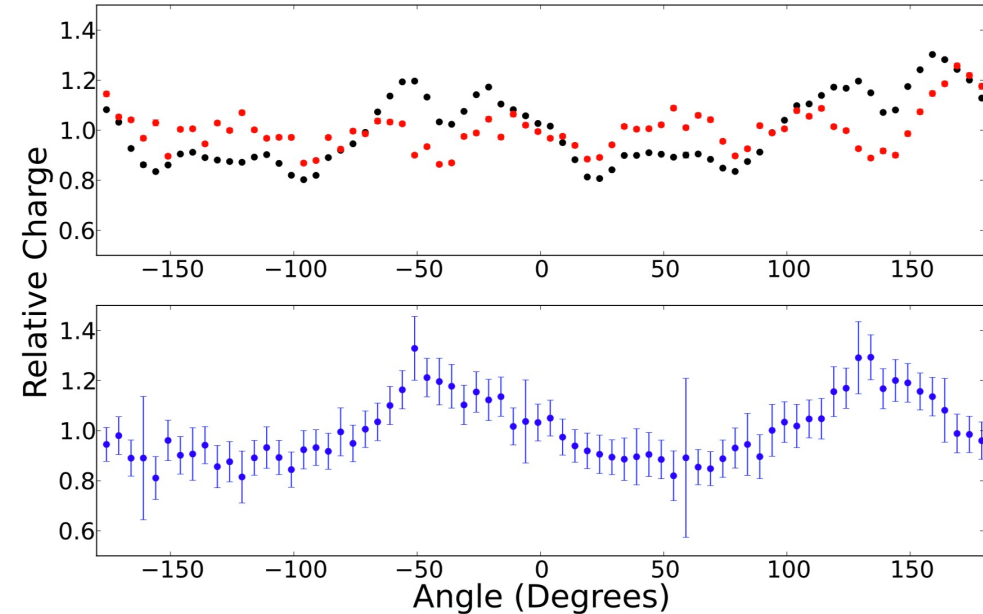
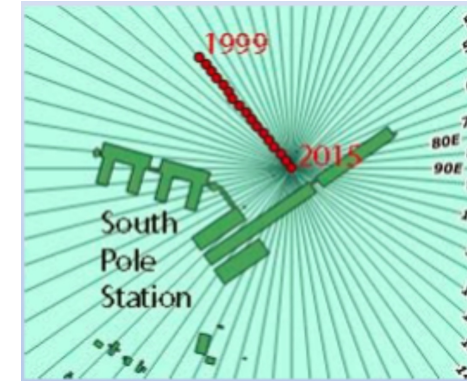
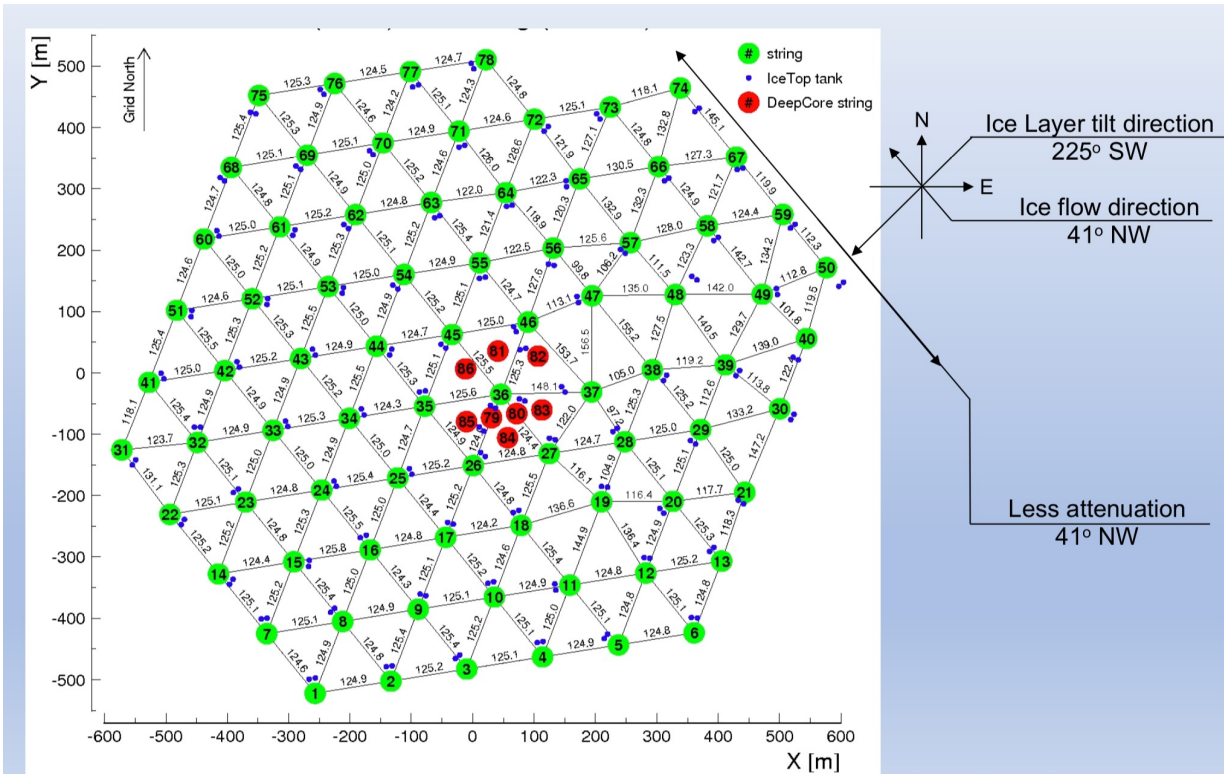

What causes the anisotropy in the ice properties?

Modeling anisotropy

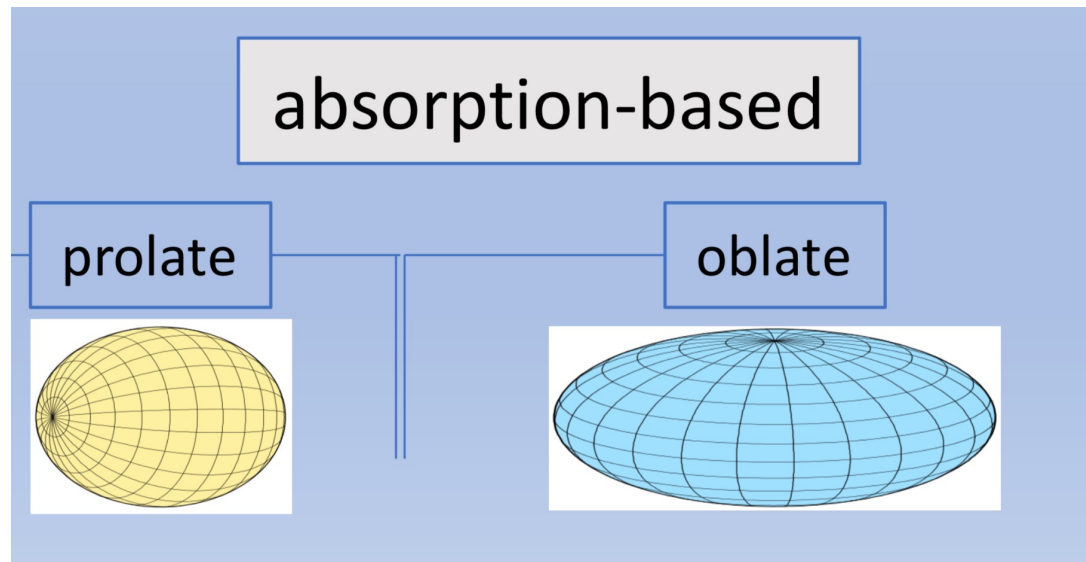

Our original hypothesis was that anisotropy might be caused by the shape/orientation of the dust grains in ice, but our current thinking is that the anisotropy is caused by birefringence due to the crystal structure of the ice itself.

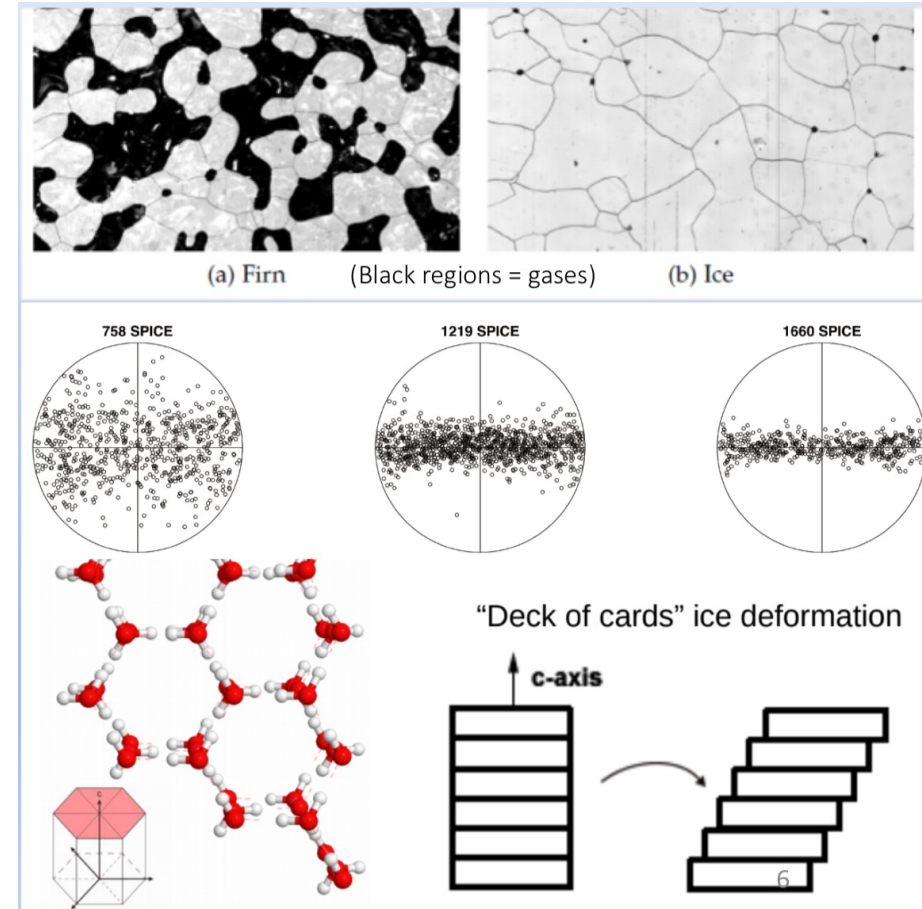

Our Understanding of IceCube's ice

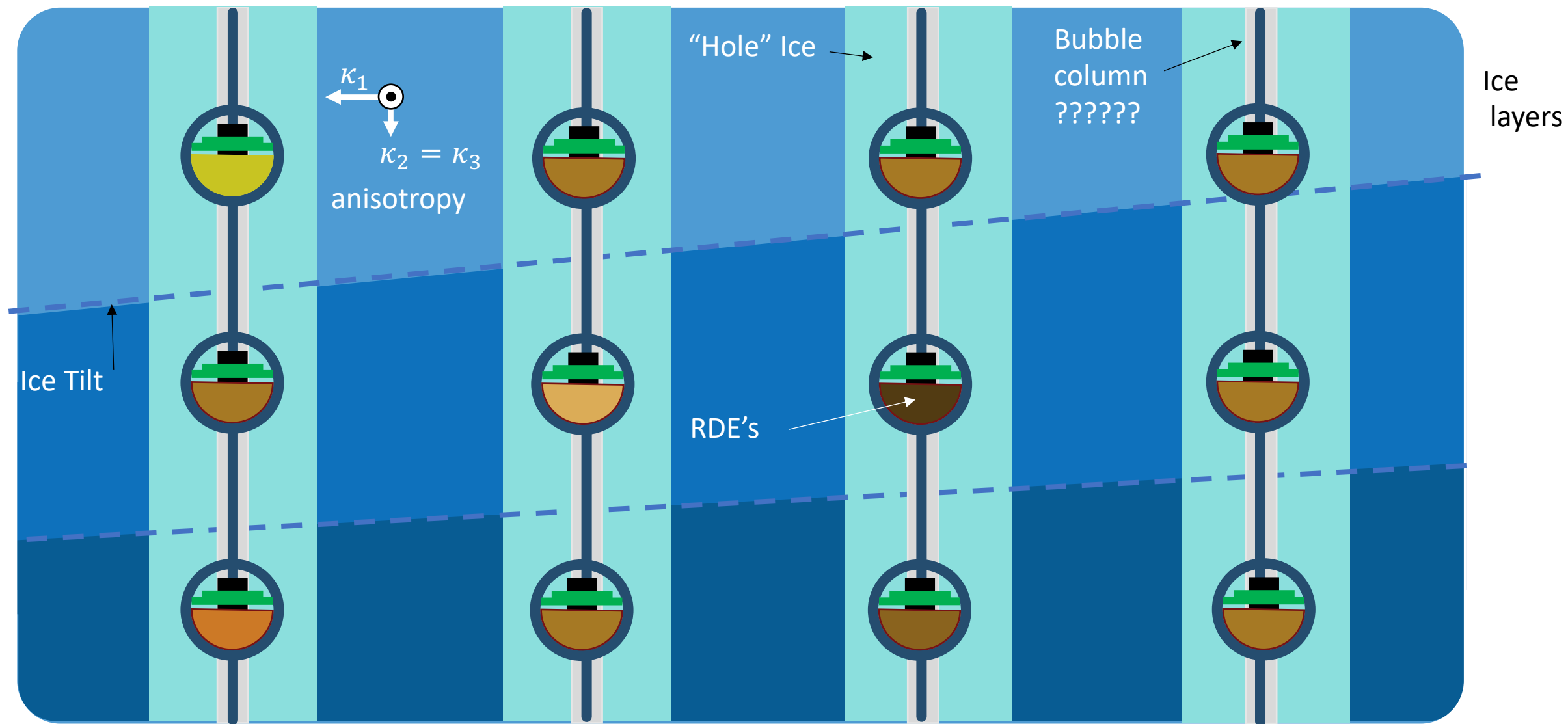

In Reality

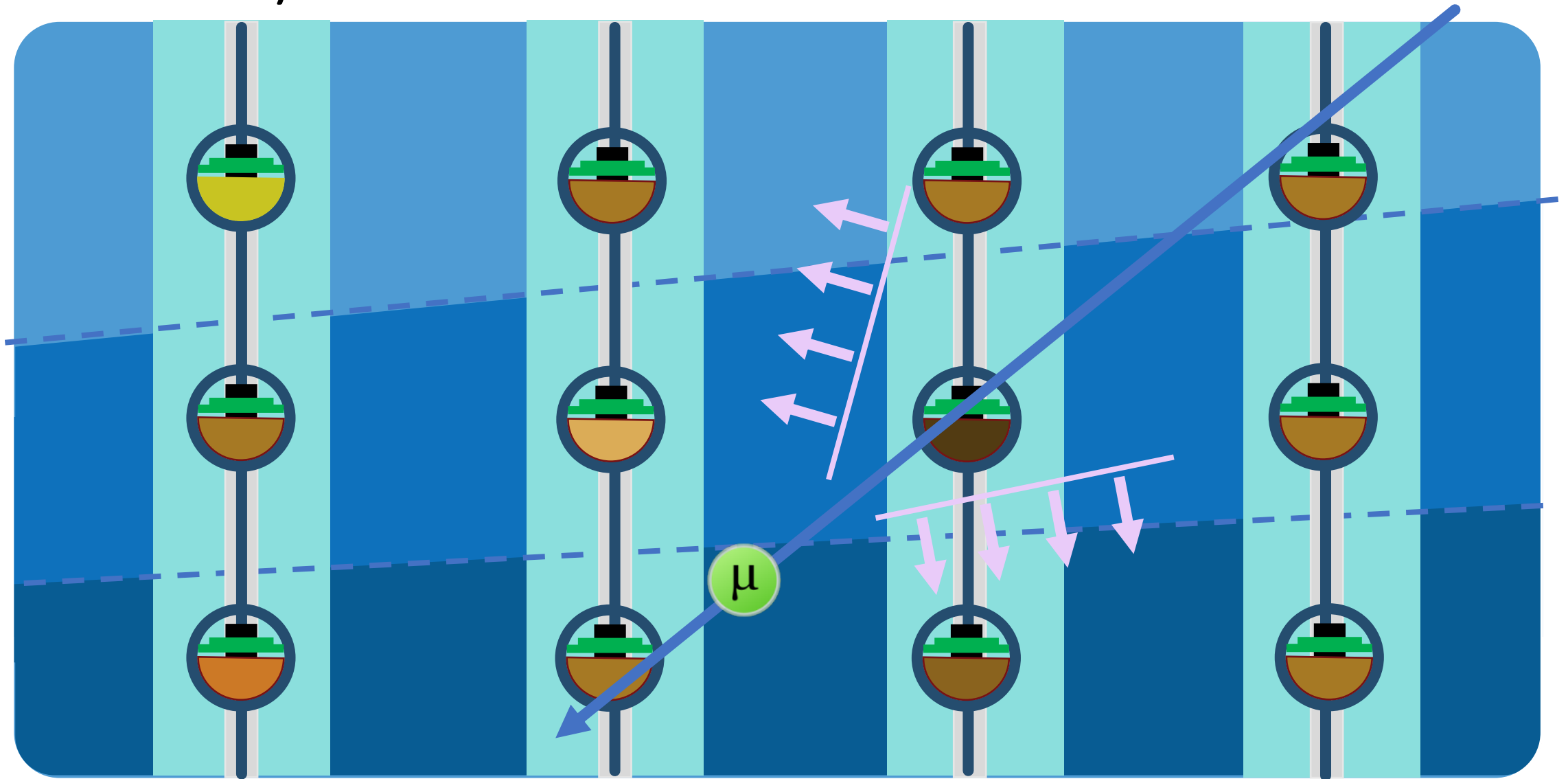

In Reality

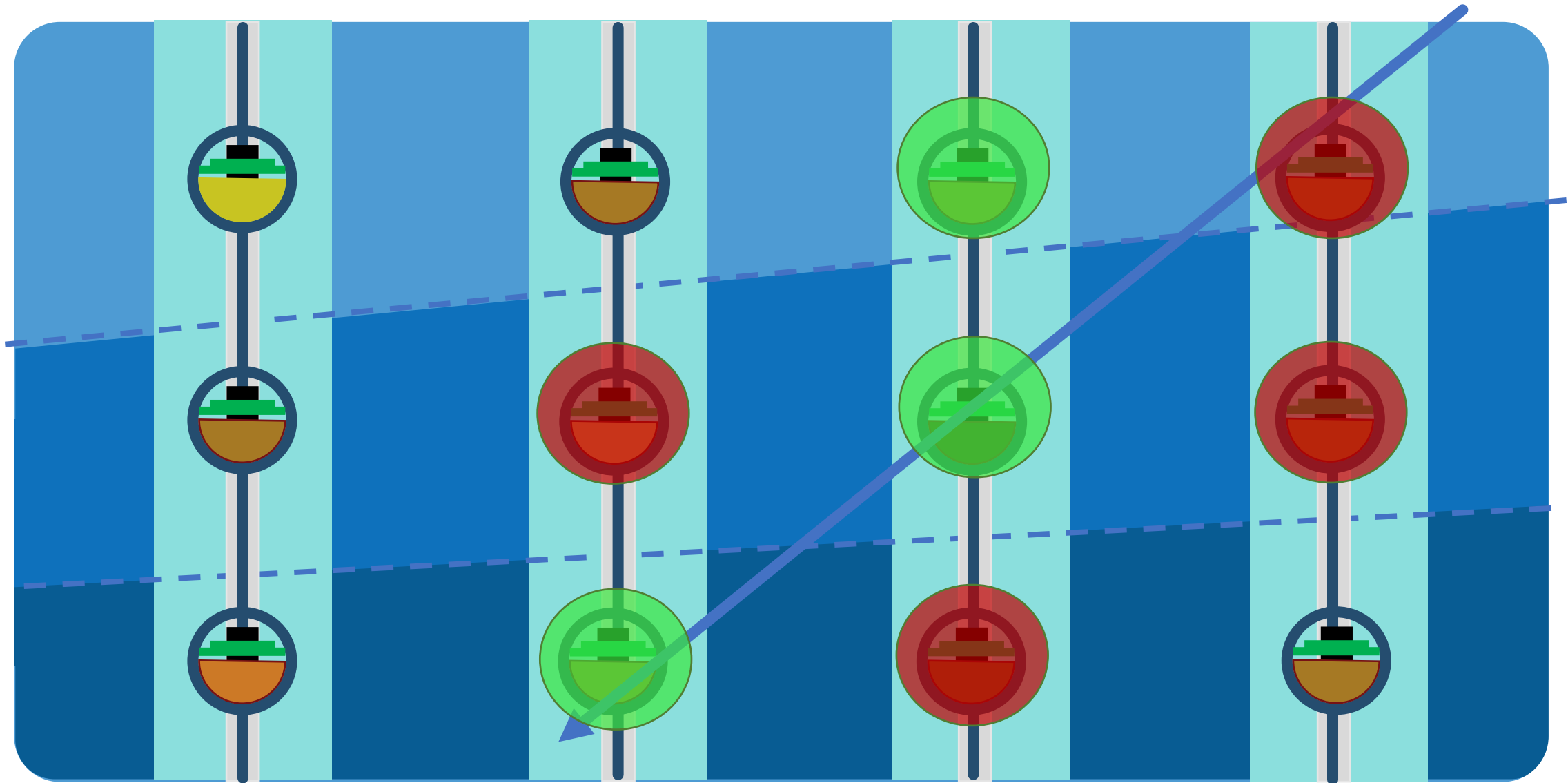

Sources of light in the ice

- The “dust logger” (deployment only)
- Occasional glowing due to the DOM HV supply
- Dark noise – mostly single hits, mostly in the glass, radioactive decay, scintillation (hundreds of Hz per DOM)
- Cosmic ray muons (several kHz)
- Products from neutrino interactions
- Artificial light sources
 - LED flashers
 - Laser “standard candle” 
 - Laser lighting for the “Swedish camera” (R.I.P.)

Calibration: from photon to data

Light source

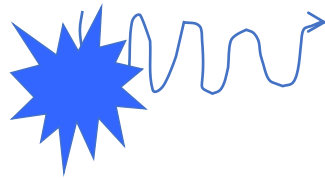

Propagation through ice

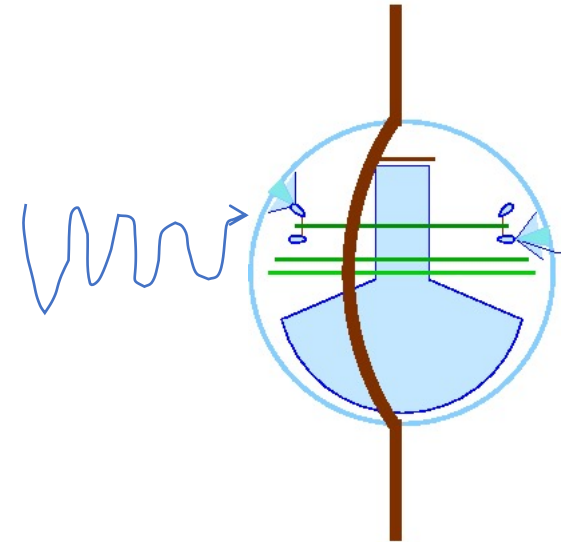
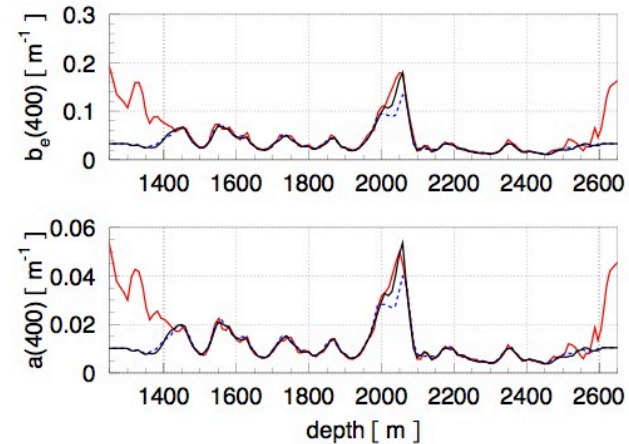

We use flashers:

- 1) To verify that DOMs are properly connected and functioning during commissioning
- 2) To verify the detector geometry
- 3) To study the optical properties of the ice
- 4) To study the response of the DOMs themselves

Flasher wiki references

- <https://wiki.icecube.wisc.edu/index.php/Flashers>
- https://wiki.icecube.wisc.edu/index.php/CDOM_Info

LED Flasher Board

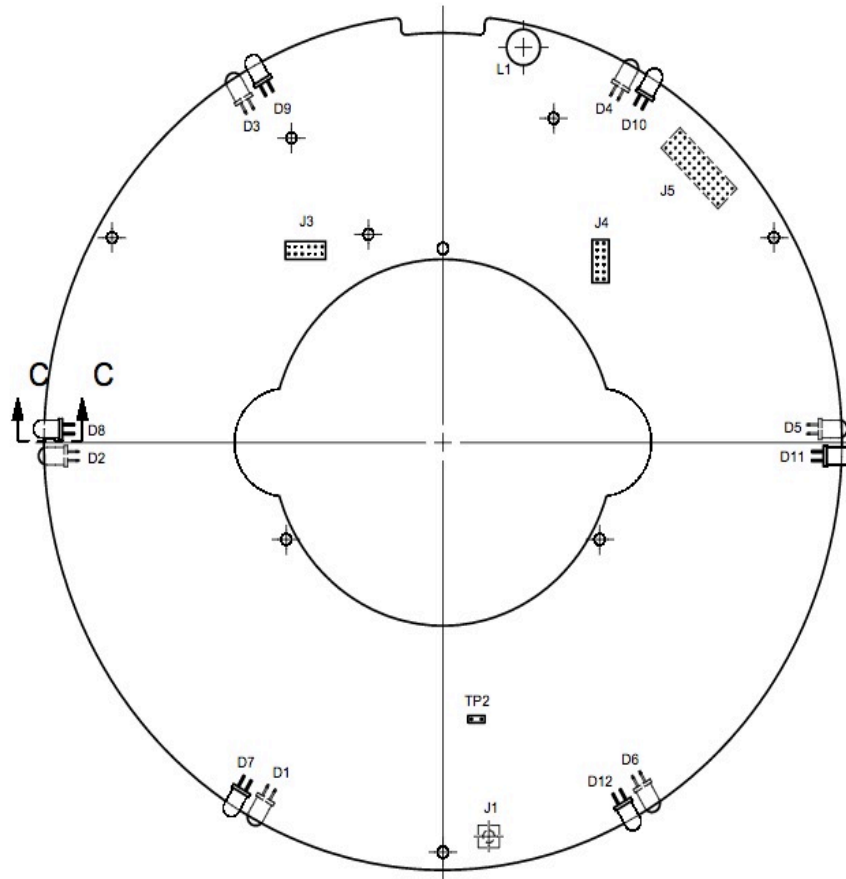

12 LEDs

Arranged in pairs,
evenly spaced 60°
apart

1&7, 2&8, 3&9,
4&10, 5&11, 6&12,
going clockwise seen
from above

1-6 are tilted, upward
at about 45° from
horizontal

7-12 are horizontal

Flasher properties

- The vast majority of IceCube LEDs are ETG-5UV405-30, nominally 405 nm wavelength, actually 399 nm, FWHM of 14 nm

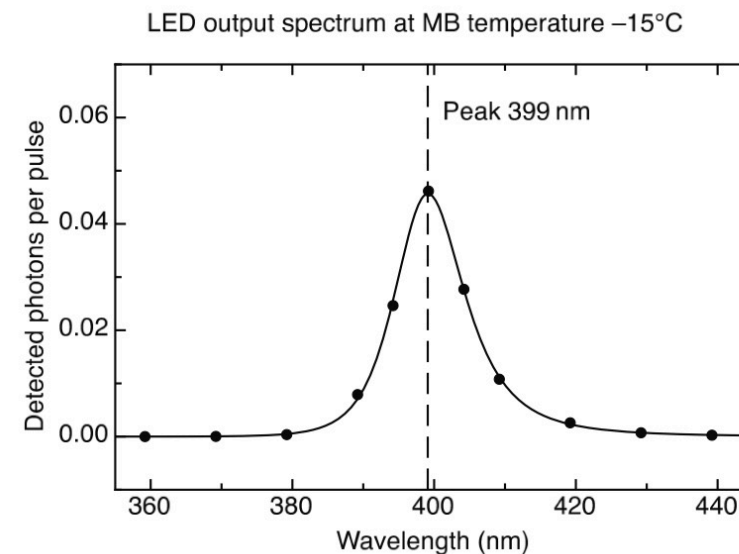
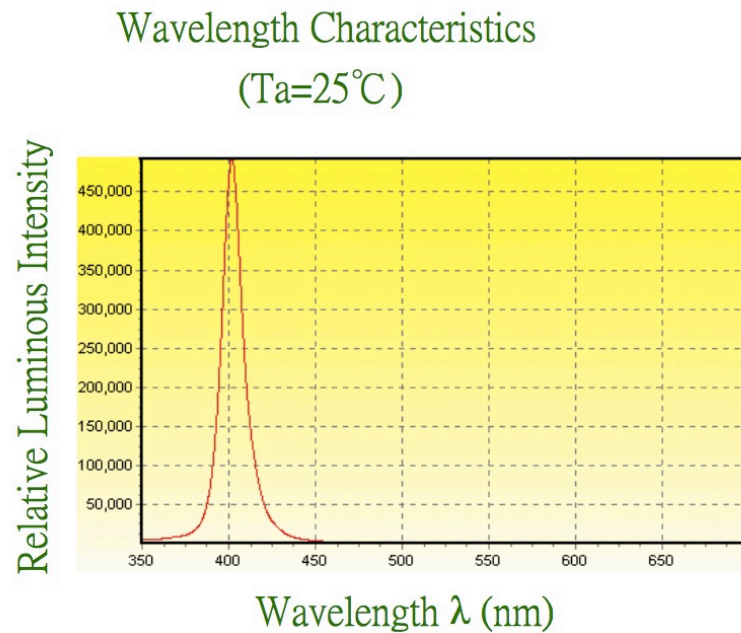

cDOMs

- 8 DOMs each on string 14 and string 79 have multiwavelength flashers called cDOMs
- See the CDOM wiki for the appropriate masks
- For the remainder of this lesson we will use the standard 400 nm flashers

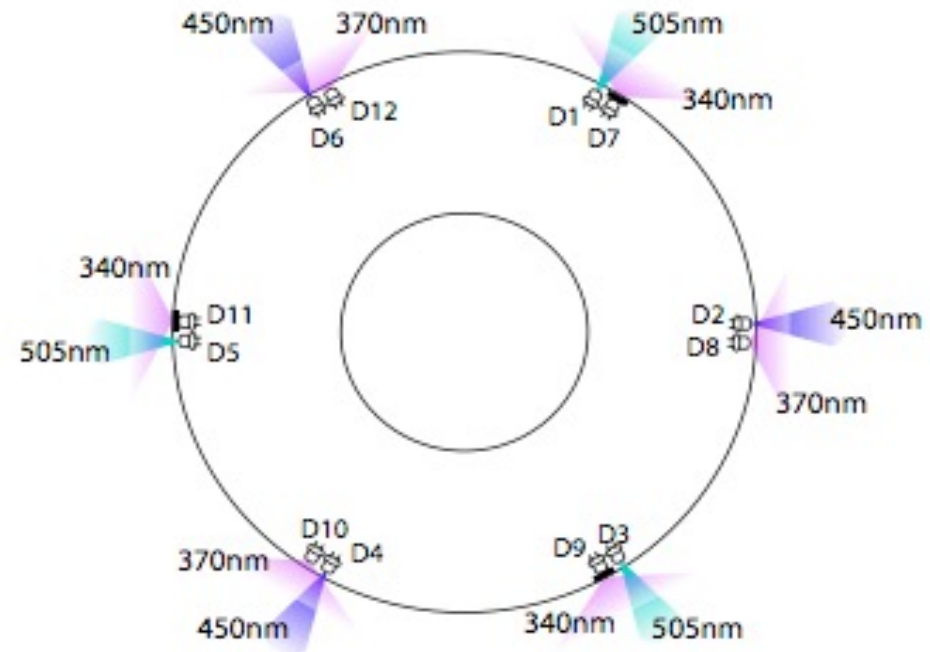

Flasher properties: Angular emission profile (beam width)

- Nominal beam width is 30° in air
- In ice, accounting for refraction from air to glass and glass to ice, the beam width is 10°
- Can be modeled as a 2-D Gaussian with $\sigma = 10^\circ$ in both directions

Beam Pattern

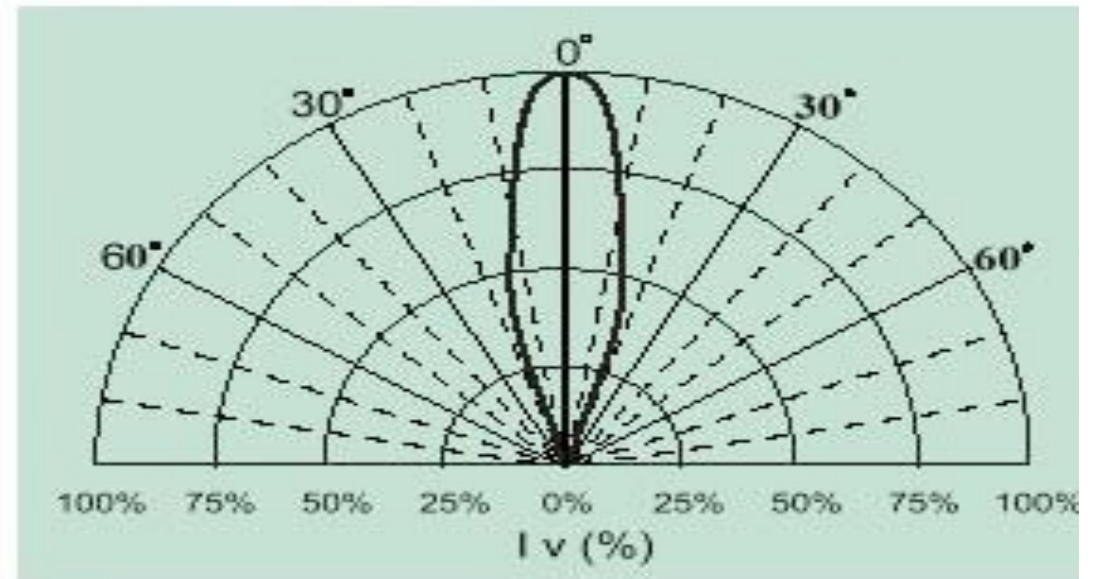

Flasher operating parameters

Parameter	Allowed values	Description
string	1 - 86	String where flashing DOM is located
DOM	1 - 60	Flashing DOM number
brightness	0 - 127	LED driver current intensity, up to 240 mA
width	0 - 127	2x duration of LED current pulse, in ns
mask	0001 - 0FFF	Hex representation of bitmask controlling which LEDs flash
rate	0 - 610	Rate of LED flashes in Hz

Flasher operation: String and DOM

- Multiple flashers can be run simultaneously
- The data acquisition system can withstand at least 3x the normal background rate from muons (~70 bright flashing DOMs simultaneously)
- A typical run might have a few to ~30 flashers simultaneously
- Neighboring flashers on the same string cannot run simultaneously
- Old DOMs (produced in 2004 and 2005) have “afterburst” properties
- Flashers cannot be synchronized using the current firmware

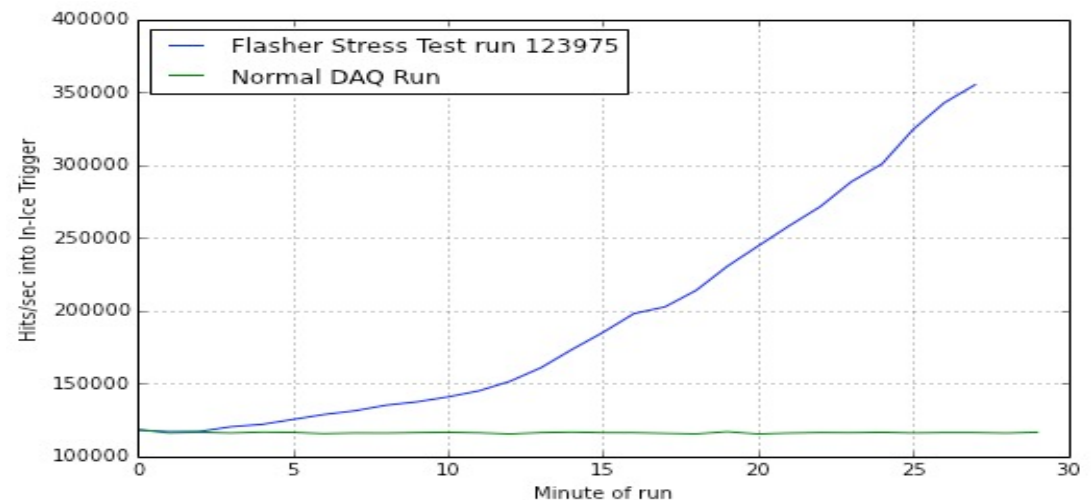

Running flashers: brightness and width

- Maximum photon output per LED is 1.17×10^{10} photons per flash
- With all 12 LEDs running this is about equal to a 500 TeV cascade
- The brightness and width parameters determine the photon output
 - Width: duration of driver current, effectively 10-70 ns
 - Brightness: amplitude of driver current, up to 240 mA

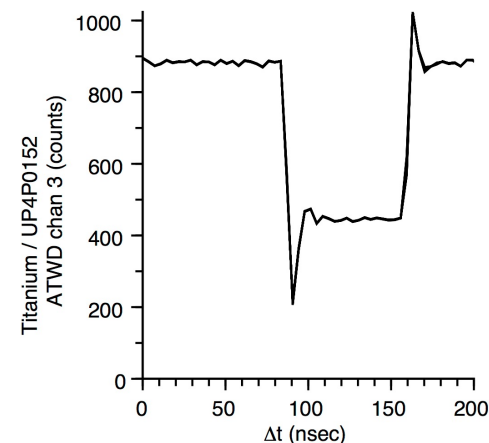
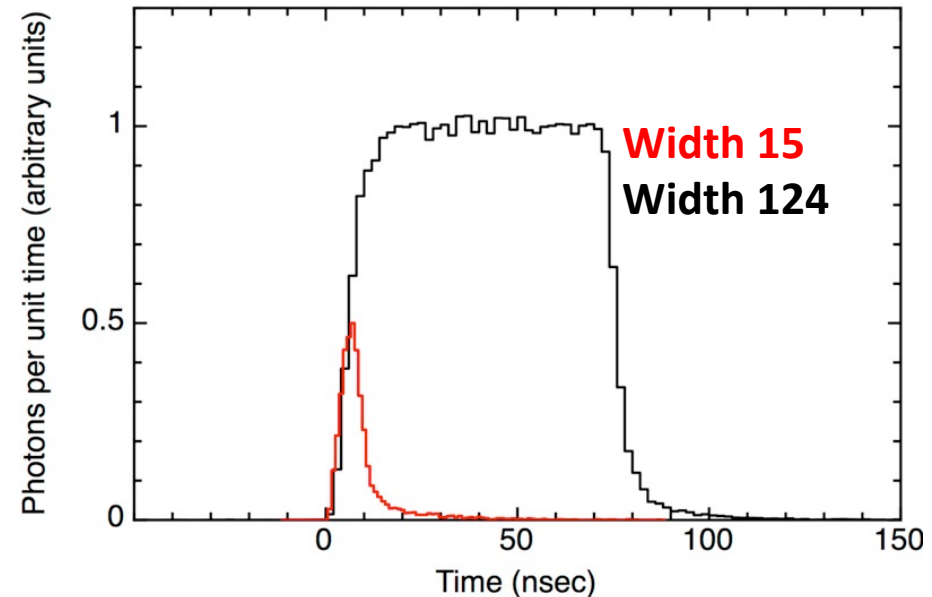

How light
output scales
with
brightness and
width

Flasher light output model

$$L = (0.0006753 + 0.000055927 B) \times (W + 13.8525 - 57.4525 / (1 + B / 34.426))$$

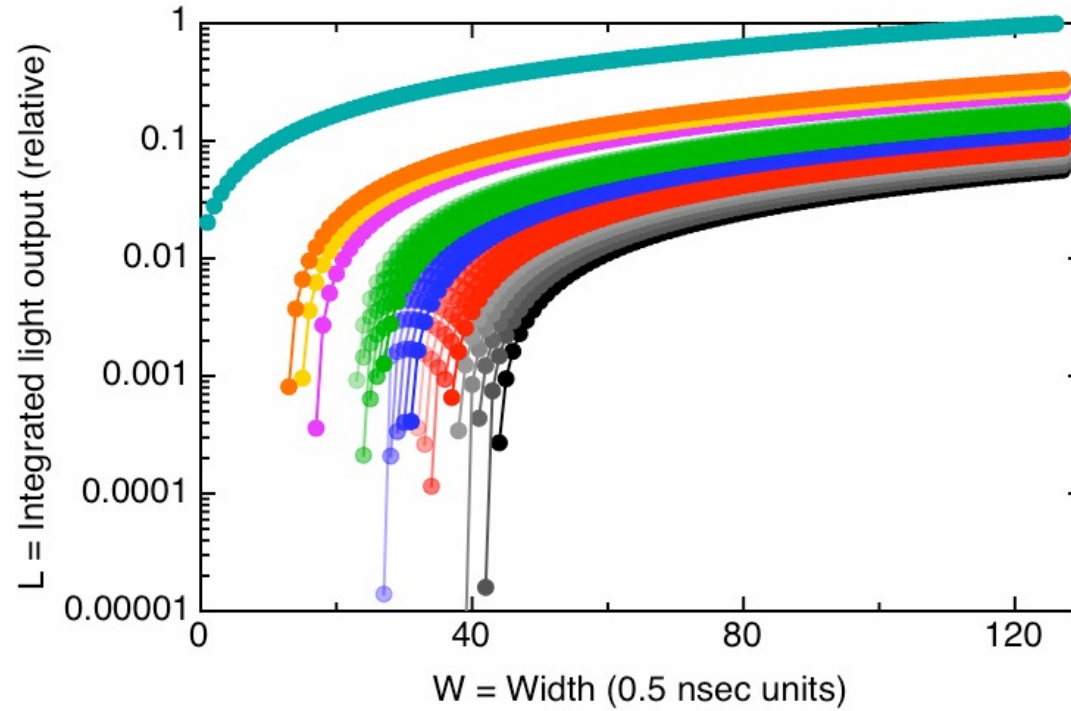

Brightness setting

- B=0
- B=1
- B=2
- B=3
- B=4
- B=5
- B=6
- B=7
- B=8
- B=9
- B=10
- B=11
- B=12
- B=13
- B=14
- B=15
- B=16
- B=17
- B=18
- B=19
- B=20
- B=30
- B=35
- B=40
- B=127

Running flashers: mask

The 12 LEDs can be run in an combination. Each LED is controlled by a bit, and the “mask” is the hex representation of the bits

Example: flash LED 7 only

	horizontal						tilted					
LED	12	11	10	9	8	7	6	5	4	3	2	1
Bit	0	0	0	0	0	1	0	0	0	0	0	0

HEX mask is 0064

Running flashers: mask

The 12 LEDs can be run in an combination. Each LED is controlled by a bit, and the “mask” is the hex representation of the bits

Example: flash all tilted LEDs

	horizontal						tilted					
LED	12	11	10	9	8	7	6	5	4	3	2	1
Bit	0	0	0	0	0	0	1	1	1	1	1	1

HEX mask is 003f

Running flashers: mask

The 12 LEDs can be run in an combination. Each LED is controlled by a bit, and the “mask” is the hex representation of the bits

Example: flash all horizontal LEDs

	horizontal						tilted					
LED	12	11	10	9	8	7	6	5	4	3	2	1
Bit	1	1	1	1	1	1	0	0	0	0	0	0

HEX mask is 0fc0

Running flashers: rate

- Maximum rate is 610 Hz, lower rates are 610 Hz divided by a power of 2
- The setting in the configuration is an integer, the actual value of the rate is the next lowest value to that integer which is 610 divided by a power of 2
- So for example if the rate setting is 2, the actual rate is $1.191 \text{ Hz} = 610 \text{ Hz}/2^9$

Flasher data processing

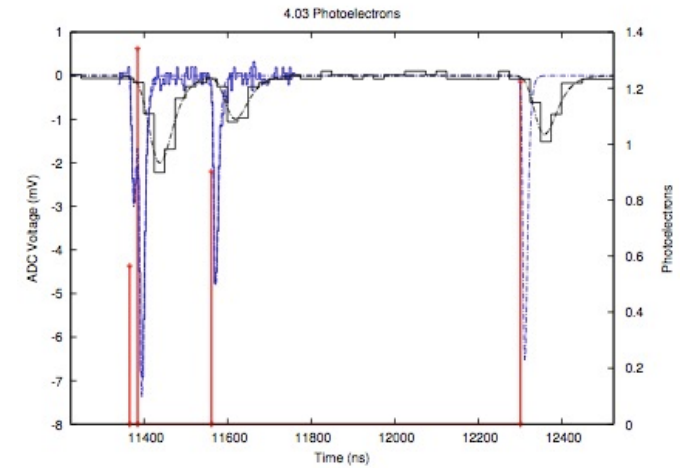
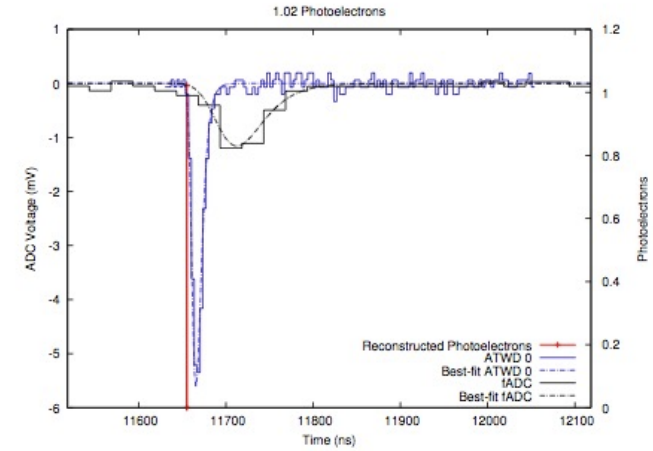
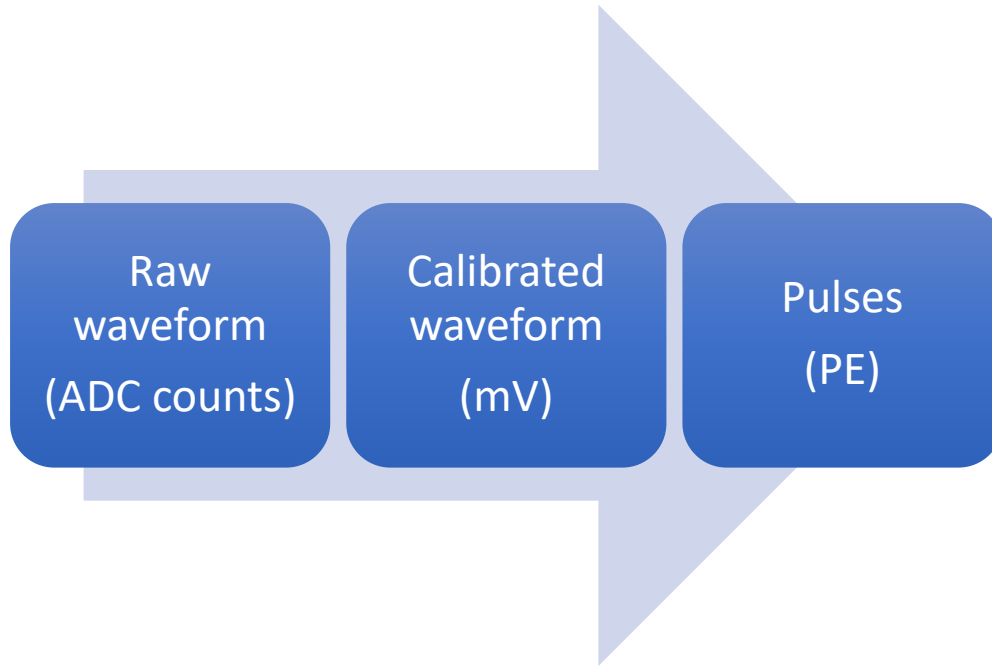

Flasher data and the ice model

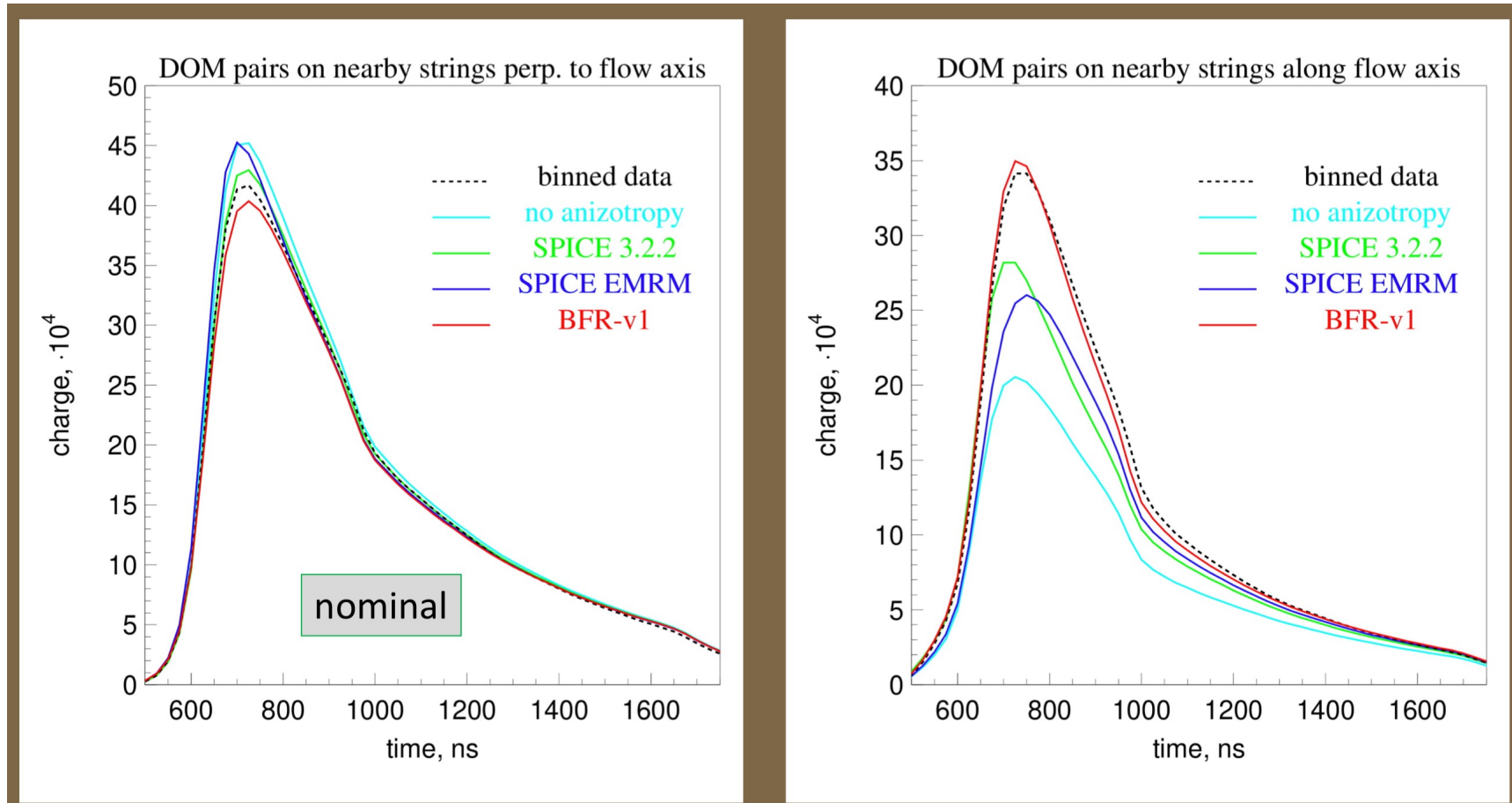

History of flasher data and the ice model

Timeline

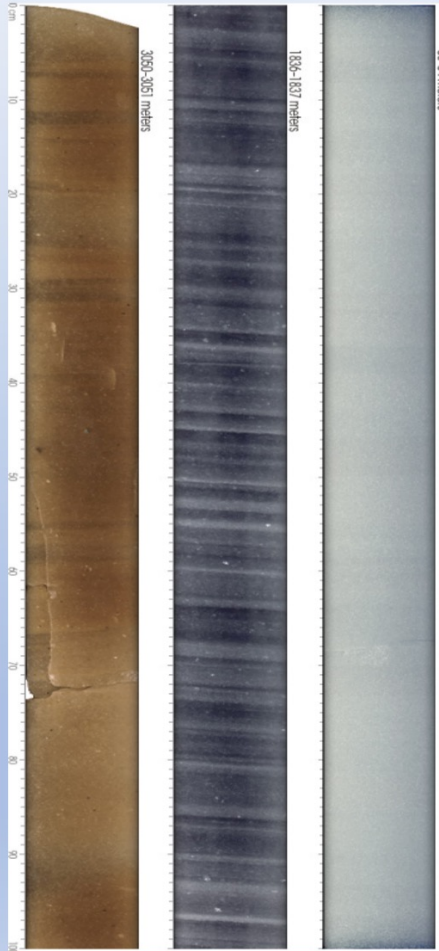

AMANDA ice models:		model error
bulk, f125, mam, mamint, stdkurt, sudkurt, kgm, ...		
millennium (published 2006) → AHA (2007)		55%
IceCube ice models:		
WHAM	(2011)	42%
SPICE 1	(2009)	29%
SPICE 2, 2+, 2x, 2y	(2010)	added ice layer tilt
SPICE Mie	(2011)	fit to scattering function
SPICE Lea	(2012)	fit to scattering anisotropy
SPICE (Munich)	(2013)	7-string, LED unfolding
SPICE ³ (CUBE)	(2014)	llh fixes, DOM sensitivity fits
SPICE 3.0	(2015)	improved RDE, ang. sens. fits
SPICE 3.1, 3.2	(2016)	85-string, correlated model fit
SPICE HD, 3.2.2	(2017)	direct HI and DOM sens., cable, DOM tilt
SPICE EMRM	(2018)	absorption-based anisotropy
SPICE BFR	(2019)	birefringence-based anisotropy

Model error (precision in charge prediction): <10%
 Extrapolation uncertainty: 13% (sca) / 15% (abs)
 Linearity: < 2% in range 0.1 ... 500 p.e.

23

Using flasher properties to verify that physics data is clear of rogue light

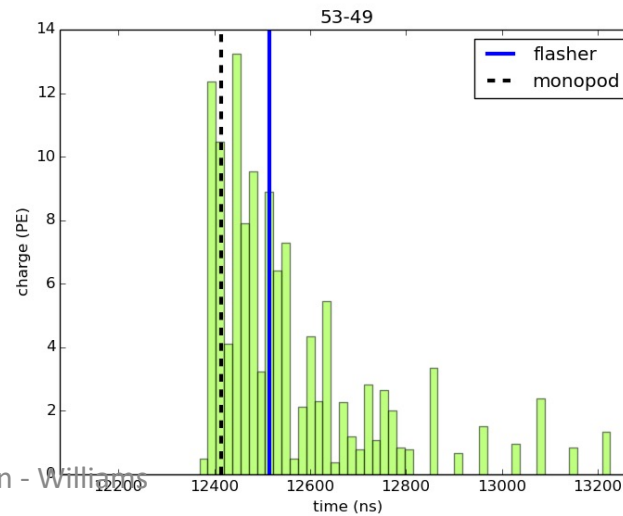
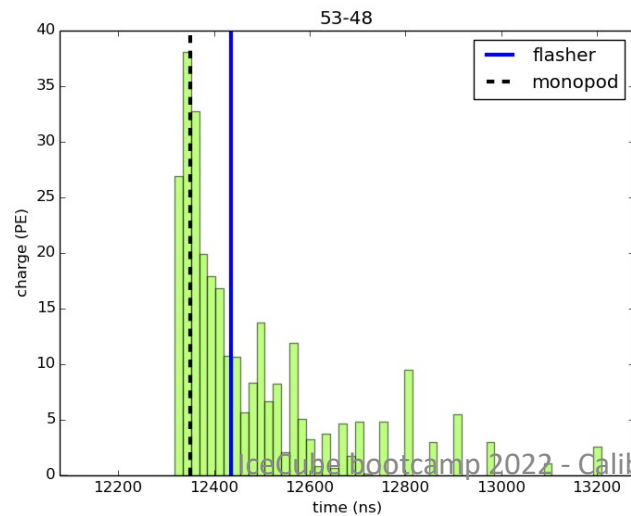
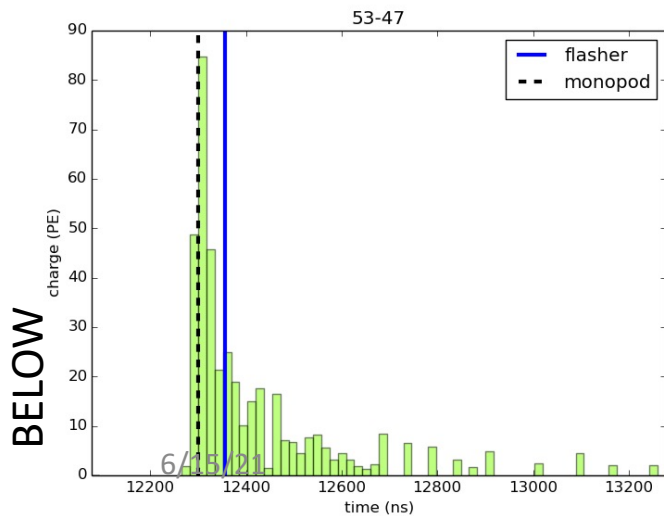
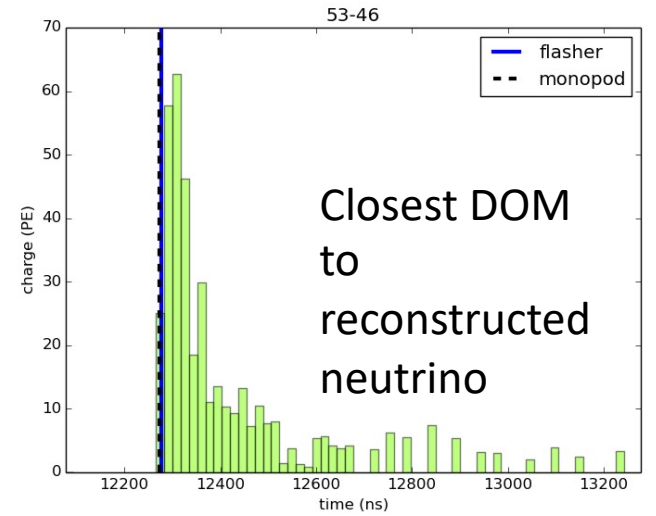
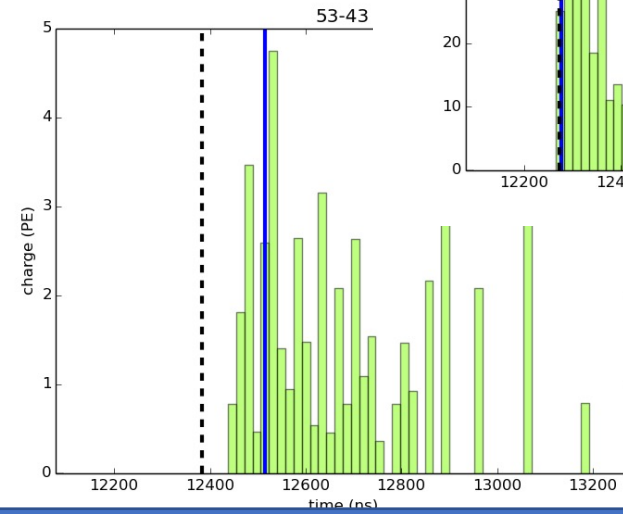
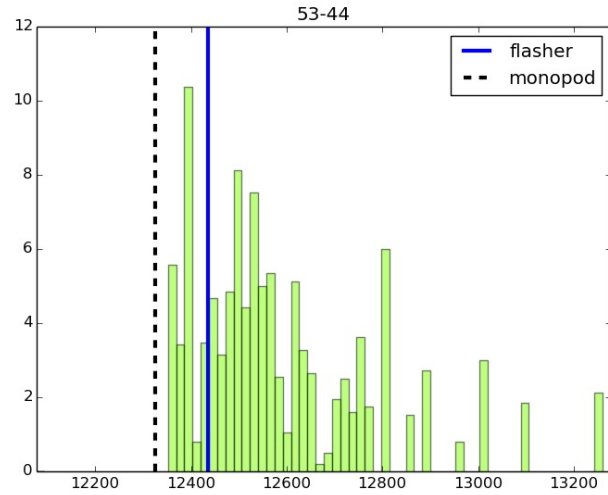
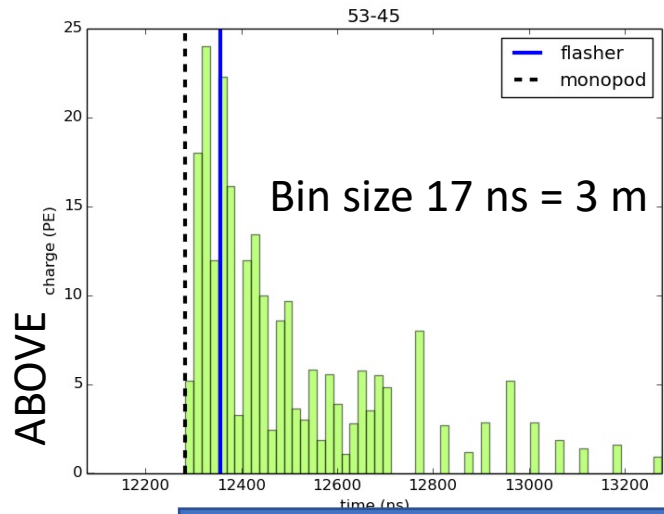

Distance from closest DOM increasing

The IceCube Upgrade

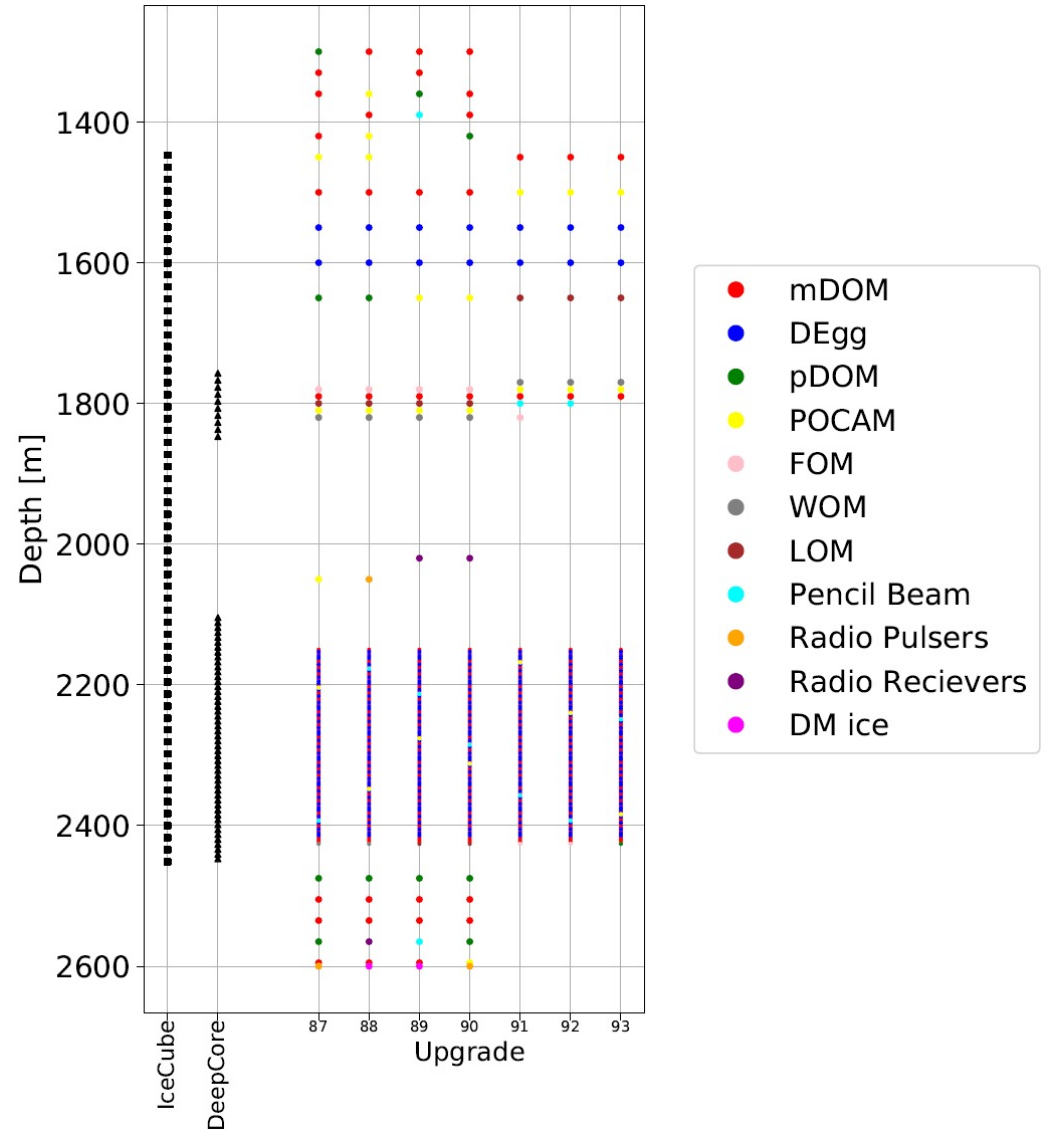
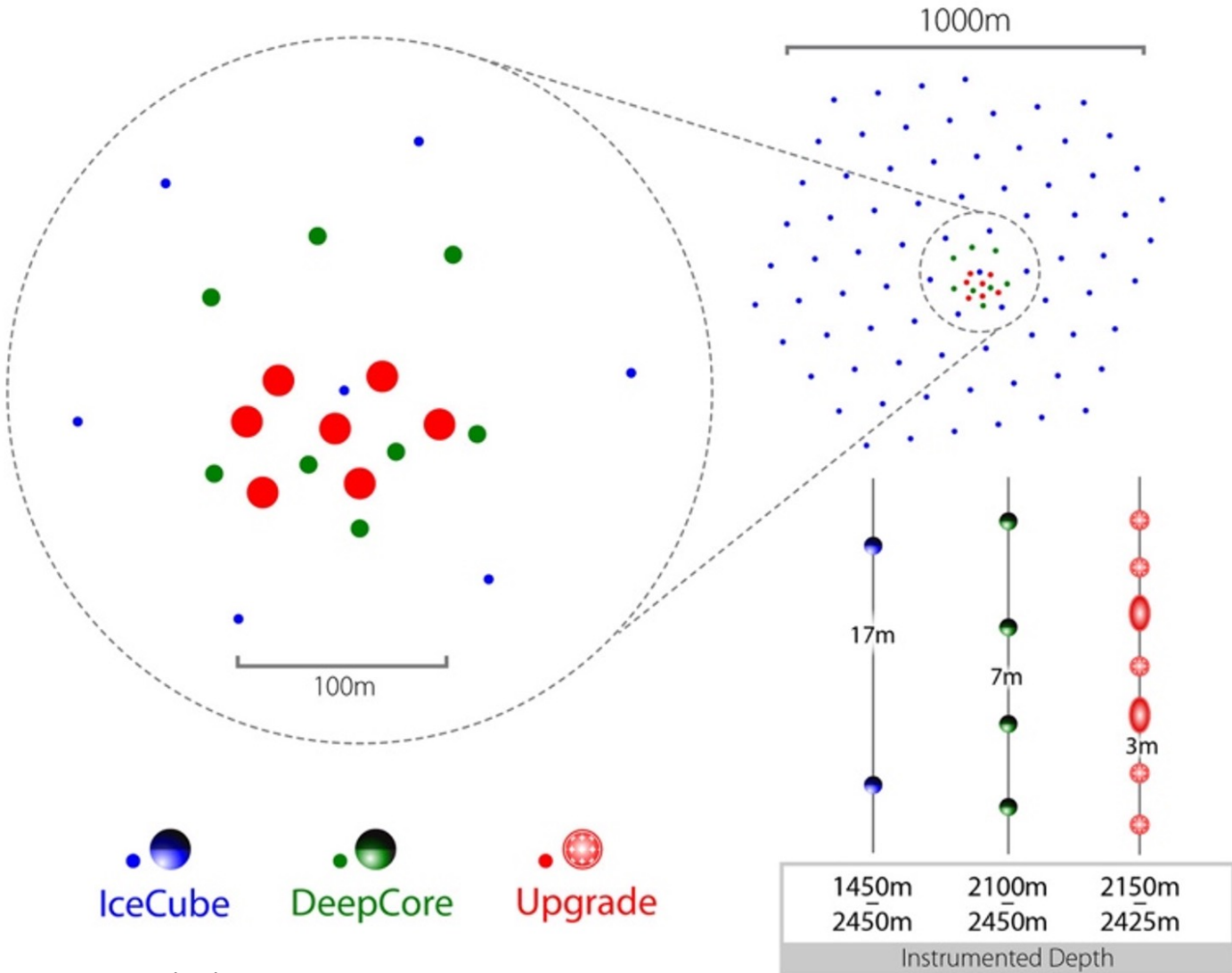

IceCube DeepCore Upgrade



IceCube Upgrade sensors are more densely spaced, with multi-PMT designs, increased photocathode area

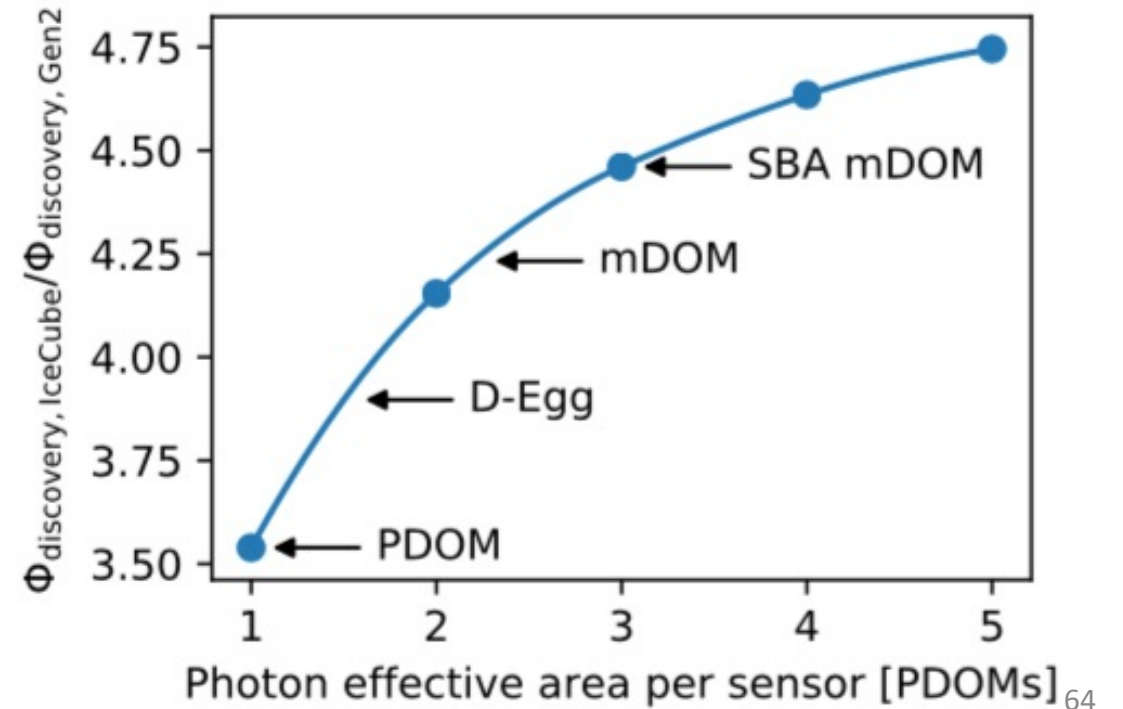
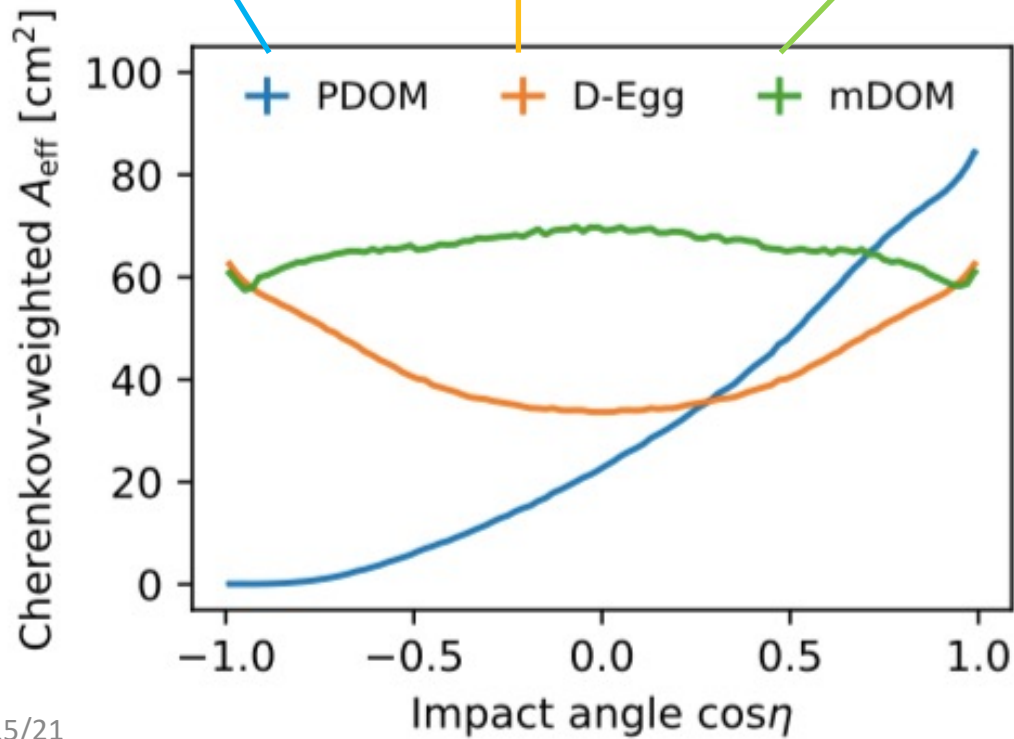

Upgrade Calibration Goals

1. Upgrade timing and geometry measurements
2. DOM optical efficiency determination *in situ* to better than 3%
3. 2x reduction in uncertainty due to refrozen hole ice
4. Determine the source and depth dependence of anisotropy in optical scattering in bulk ice
5. Measure acoustic properties of bulk ice for Gen2
6. Measure properties of ice below IceCube instrumented volume

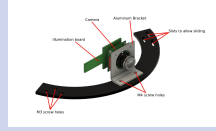
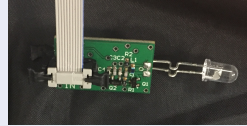
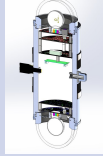
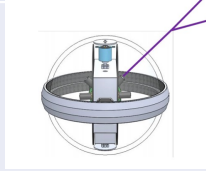
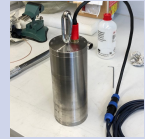
Device		Goal
Cameras		3
Flashers		1, 6
POCAM		2, 3, 6
PencilBeam		4, 6
Acoustic Modules		5, 6
Dust Logger		4, 6

The future: calibration in the IceCube Upgrade

Device	IceCube	IceCube Upgrade	Note
Flasher LEDs in DOMs	All DOMs	All DOMs	Upgrade spacing will be below a scattering length
Cameras	1 standalone camera, not onboard DOM	Onboard DOMs, additional standalone cameras	Camera has been very useful in informing us about hole ice conditions
Standalone light sources	2 laser "standard candles"	POCAM and Pencil Beam	POCAM and Pencil beam designed to be isotropic/multidirectional and probe hole ice and scattering function respectively
Acoustic sensors	None	Modules on each string	Cross-check geometry measurements, R&D for extended detector calibration
Inclinometers	50	All DOMs	Mainboard mounted off the shelf component

Light sources onboard the modules: LED flashers

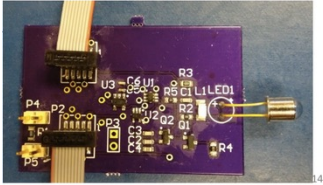
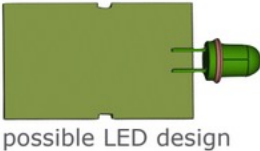
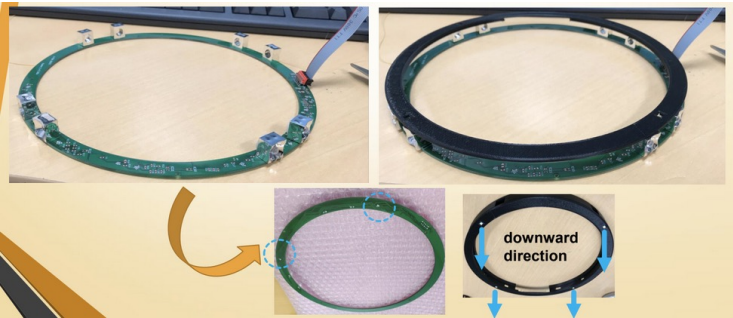

- Definitely want
- Desired if waistband and integration allows
- Only if orange spaces not possible and integration allows

(Blue circles are cameras)



mainboard

Calibration board

cameras

flashers

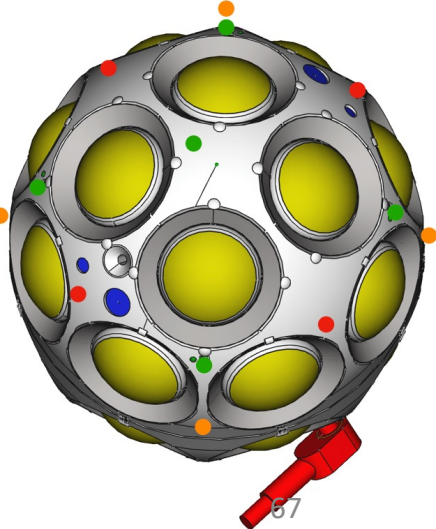
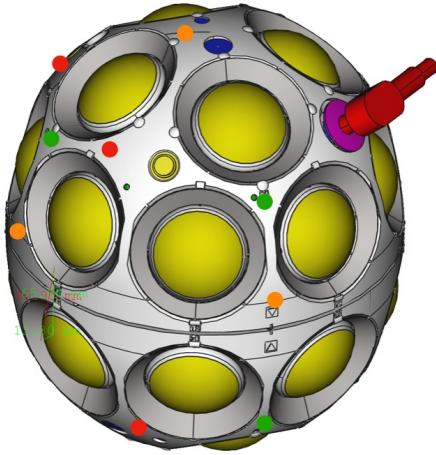
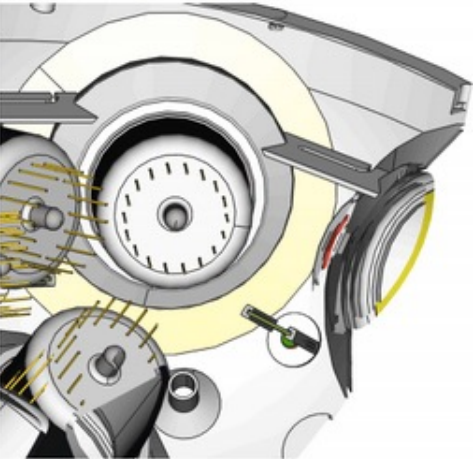

Cameras

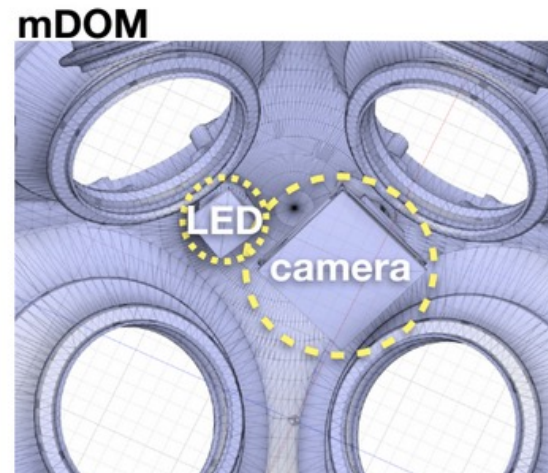
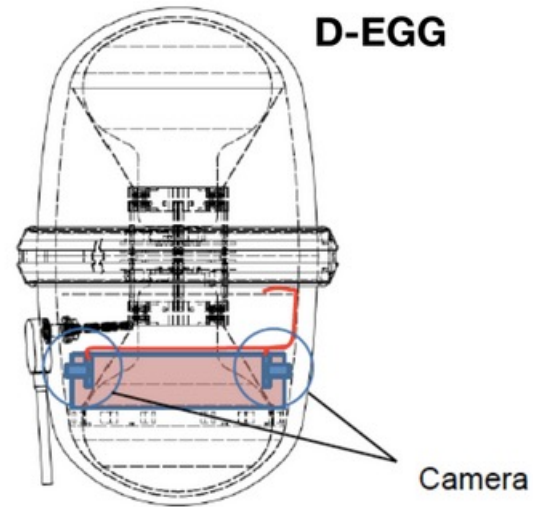
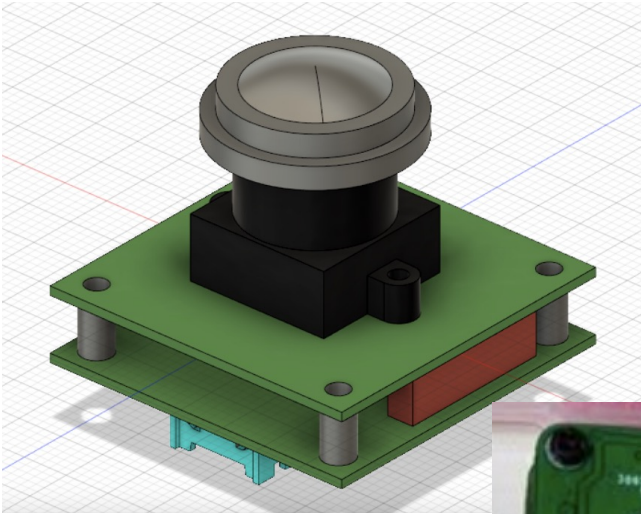

mDOM: 2 outward cameras, 1 downward

D-egg: 3 outward cameras

5 Standalone cameras which are steerable and have adjustable focus

External light sources

Pencil Beam

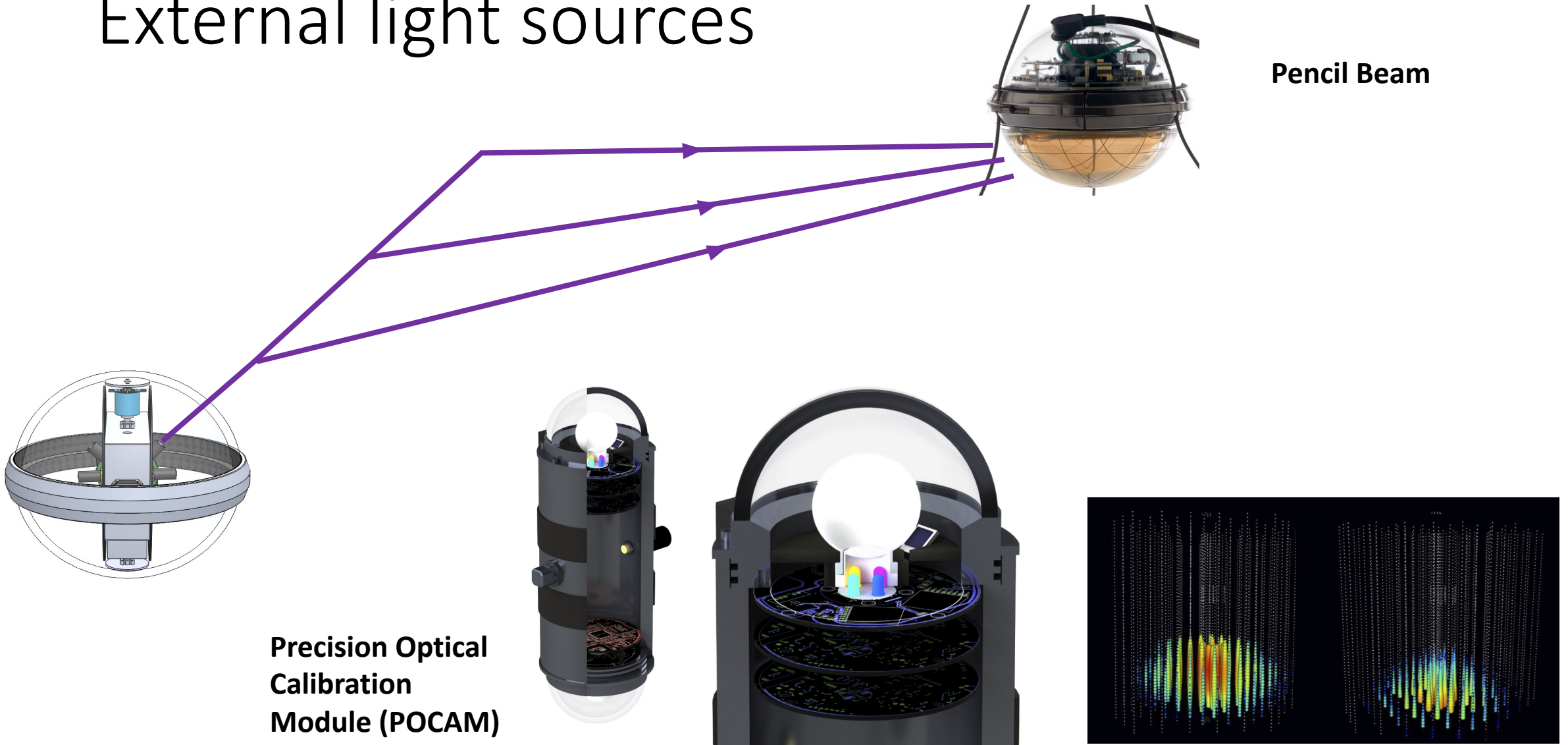

The Pencil Beam in the Upgrade

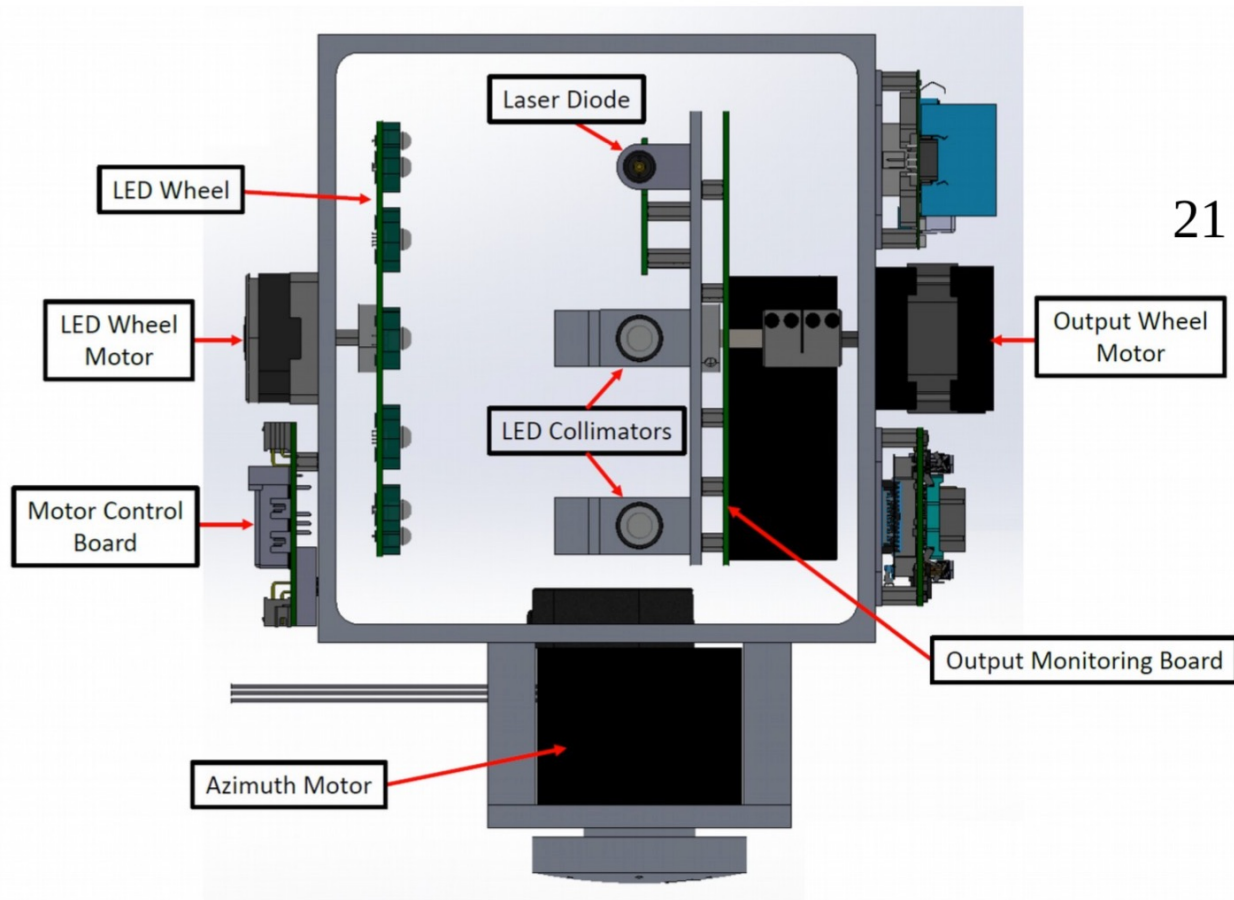

4 π steerable, ns, collimated light source

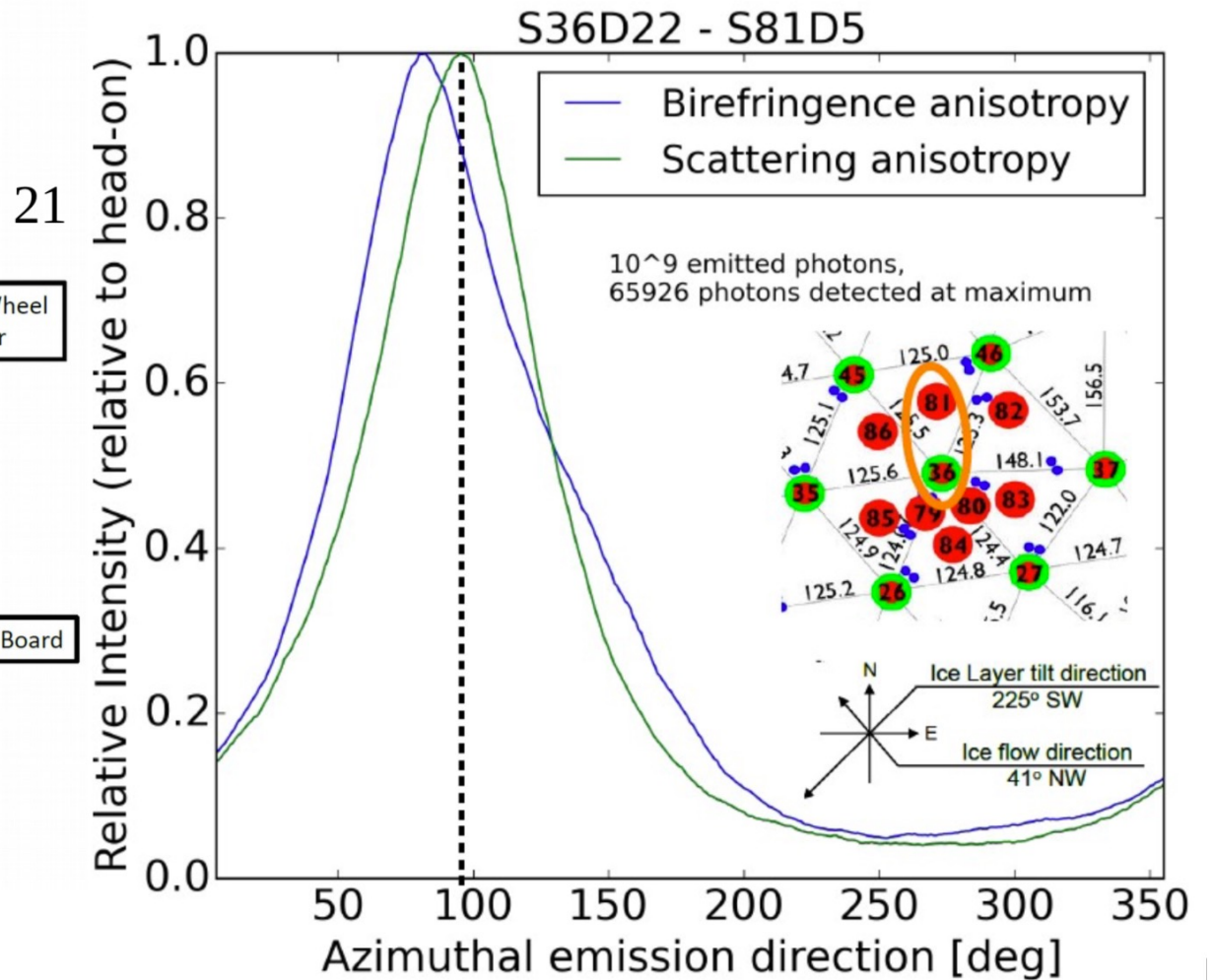

Summary

- The ice is a fundamental part of our detector and knowledge of the ice is critical to the science of IceCube
- Our model of the ice has been evolving in complexity ever since IceCube was constructed
- The IceCube Upgrade will deliver improved measurements of the ice which will be used as the basis of knowledge for the next generation IceCube detector

Backup

Vocabulary

- DOM = digital optical module
 - Basic sensor unit
- String = cable with 60 DOMs
 - 86 strings in final detector
- IceTop = surface detector
- InIce = all strings
- DeepCore = closely spaced center strings



Vocabulary

- Photomultiplier tube or PMT = light detector
- HV = high voltage
- Photoelectron: an electron ejected from a metal surface in the PMT by a photon
- Mainboard = digitizing electronics
- ATWD = analog transient waveform digitizer
 - 128 samples, 3 ns per sample
- FADC = fast analog to digital converter
- Waveform = digitized current pulse
- Timestamp = time a waveform was recorded
- Flashers = onboard LEDs for calibration

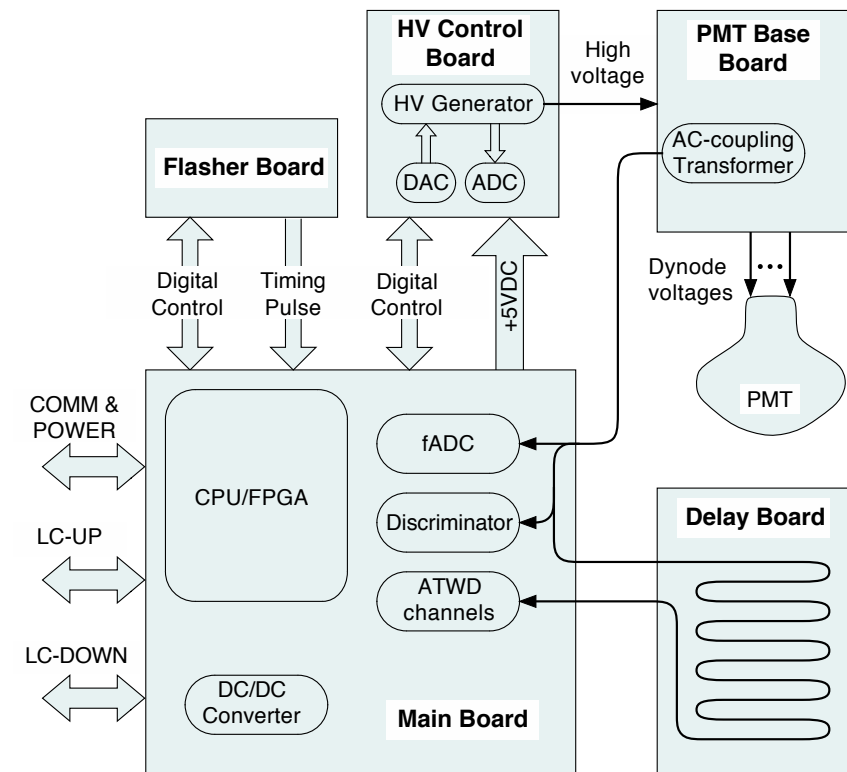
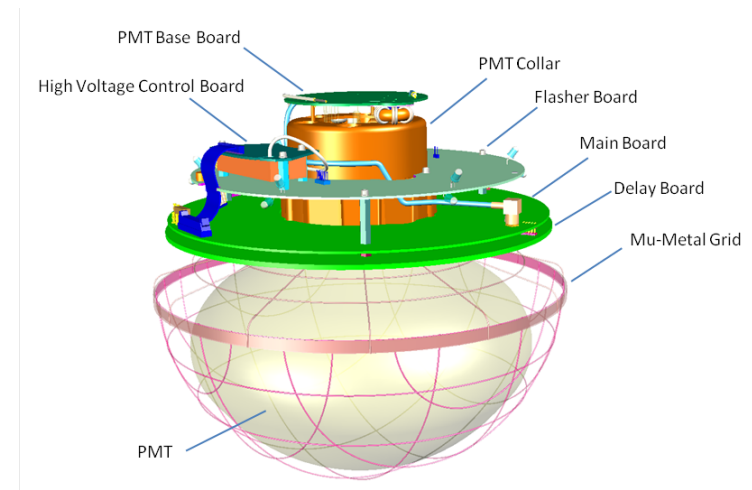

IceCube PMT

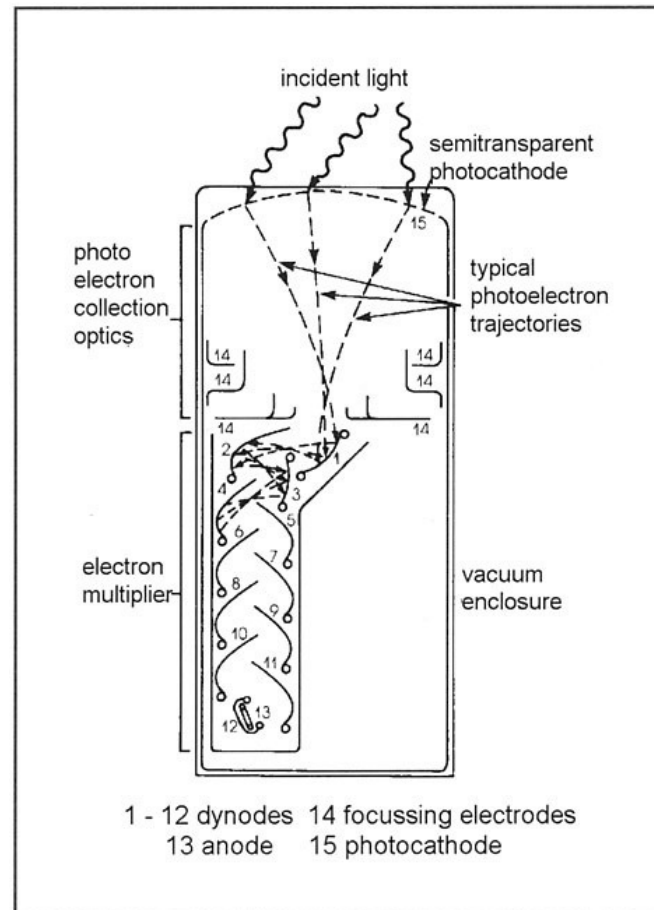
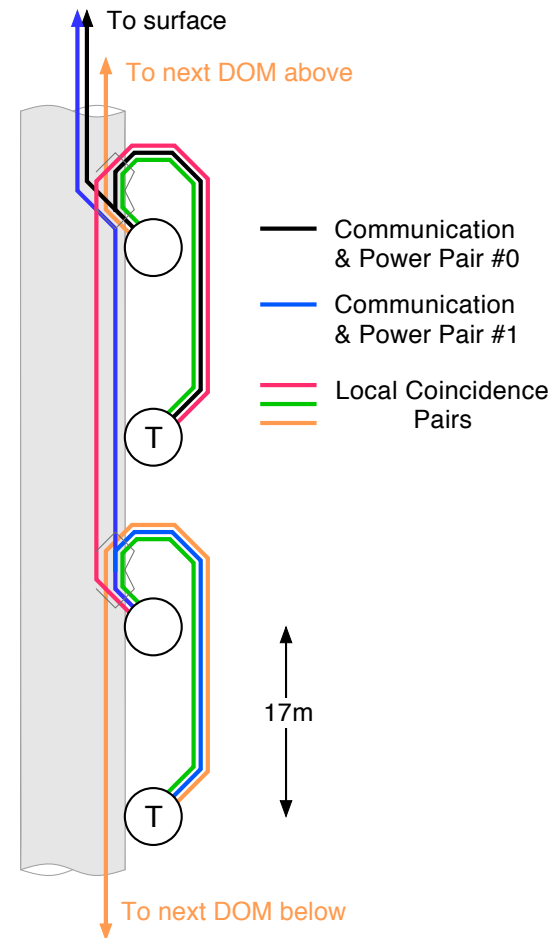

Fig. 4.1 Schematic of a photomultiplier tube.

Vocabulary

- Hit = single DOM sees light (threshold = 0.25 PE)
- Local coincidence = neighboring DOMs see light within a certain time window
- Hard Local Coincidence (HLC) = no information is sent on unless local coincidence condition is met
- Soft Local Coincidence (SLC) = only minimal information is sent on unless local coincidence condition is met
- These decisions are all made in the ice by the onboard electronics



Vocabulary

- Trigger = multiple DOMs hit in a certain pattern or time window
 - Simple majority (SMT) = some number of DOMs hit, currently 8, i.e. SMT8
 - Calibration trigger = flashers
 - Minimum bias/minbias trigger = capture whatever is in the detector regardless of pattern
 - Many others

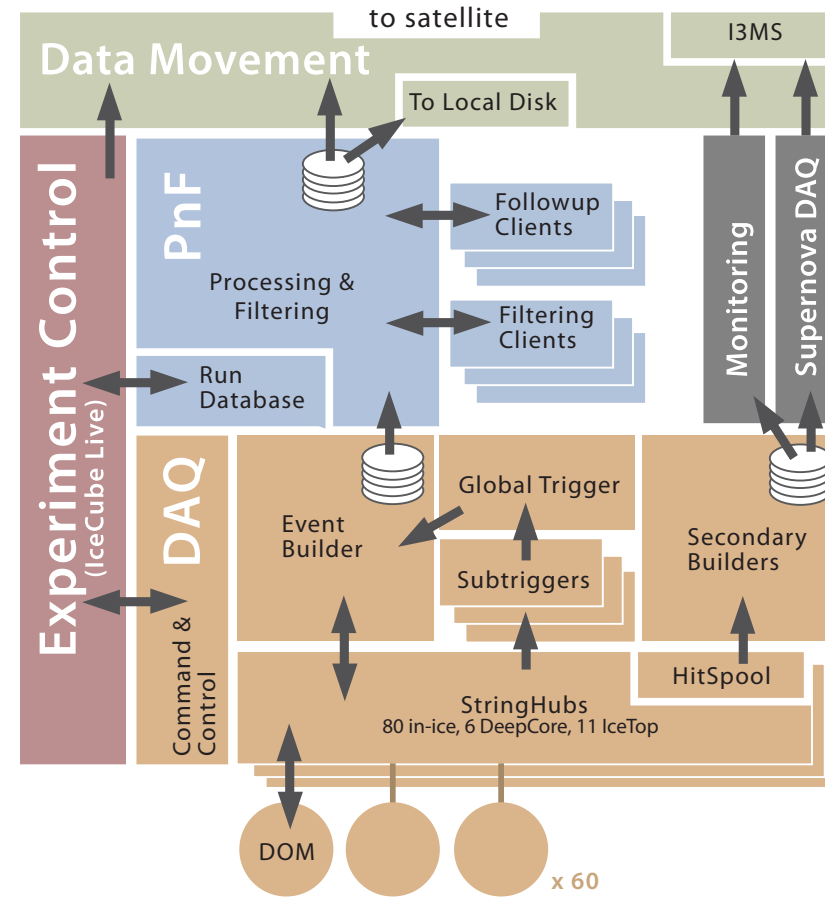

Vocabulary

- Event = all information captured within a certain time window around a trigger
 - An event may have multiple triggers
- Event Builder = software that constructs events
- Processing and filtering (PNF) = software that runs online data reduction
- Online = realtime data processing
- Offline = non-realtime data processing

