

The IceCube Detector

John Kelley
IceCube Detector Operations Manager
UW-Madison

IceCube Bootcamp, 2022-06-13

with thanks to C. Wendt, N. Kurahashi Neilson, E. Blaufuss, and D. Glowacki

The IceCube Detector

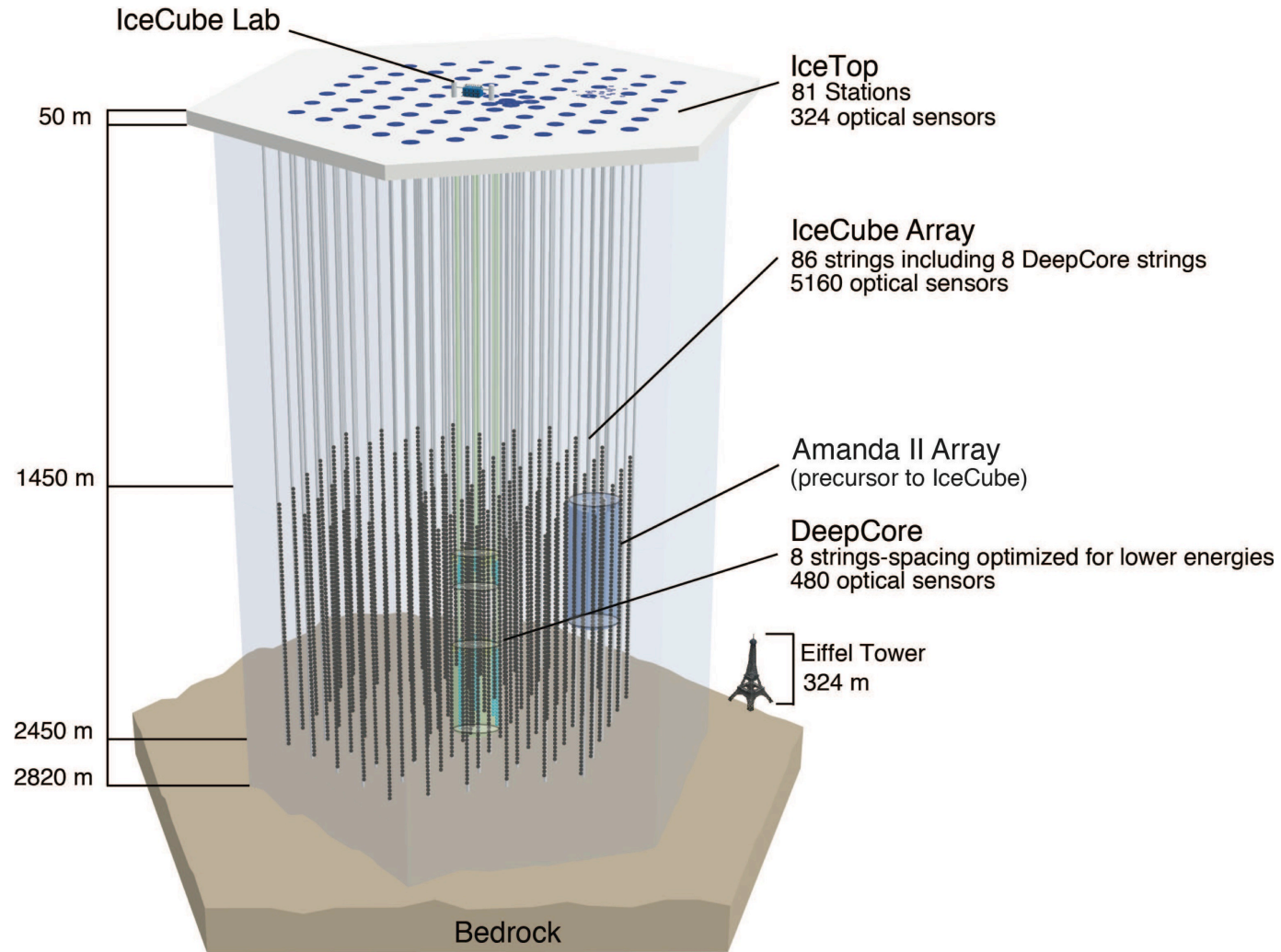
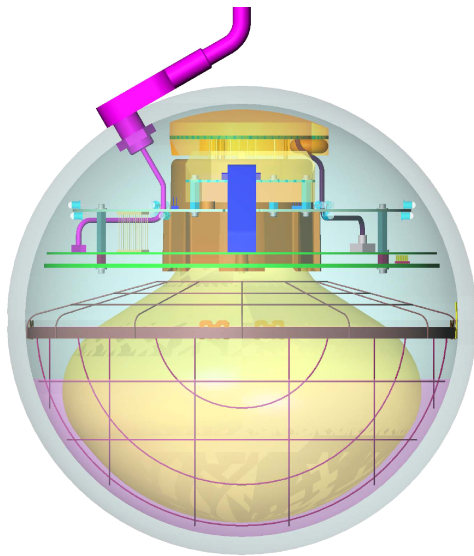
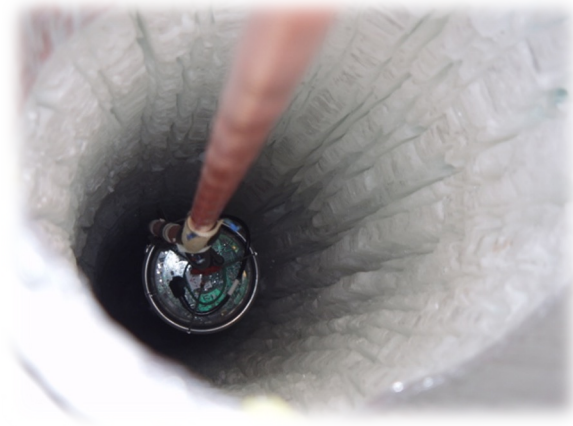

digital optical module (DOM)

Detection Principle and Event Types

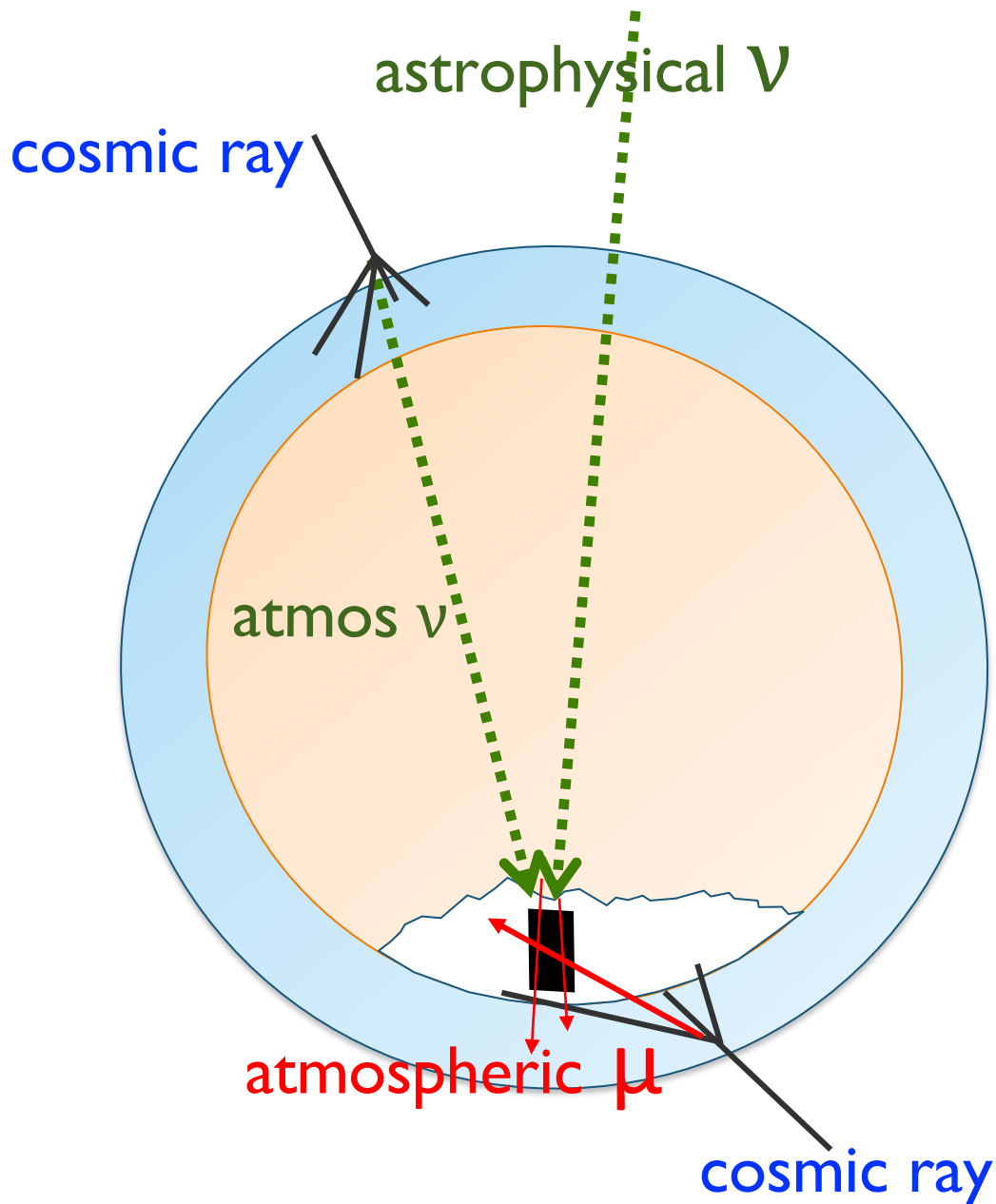

Cosmic-ray muons: ~ 3000 / second
Atmospheric neutrinos: ~ 1 / 5 minutes
Astrophysical neutrinos: ~ 1 / month

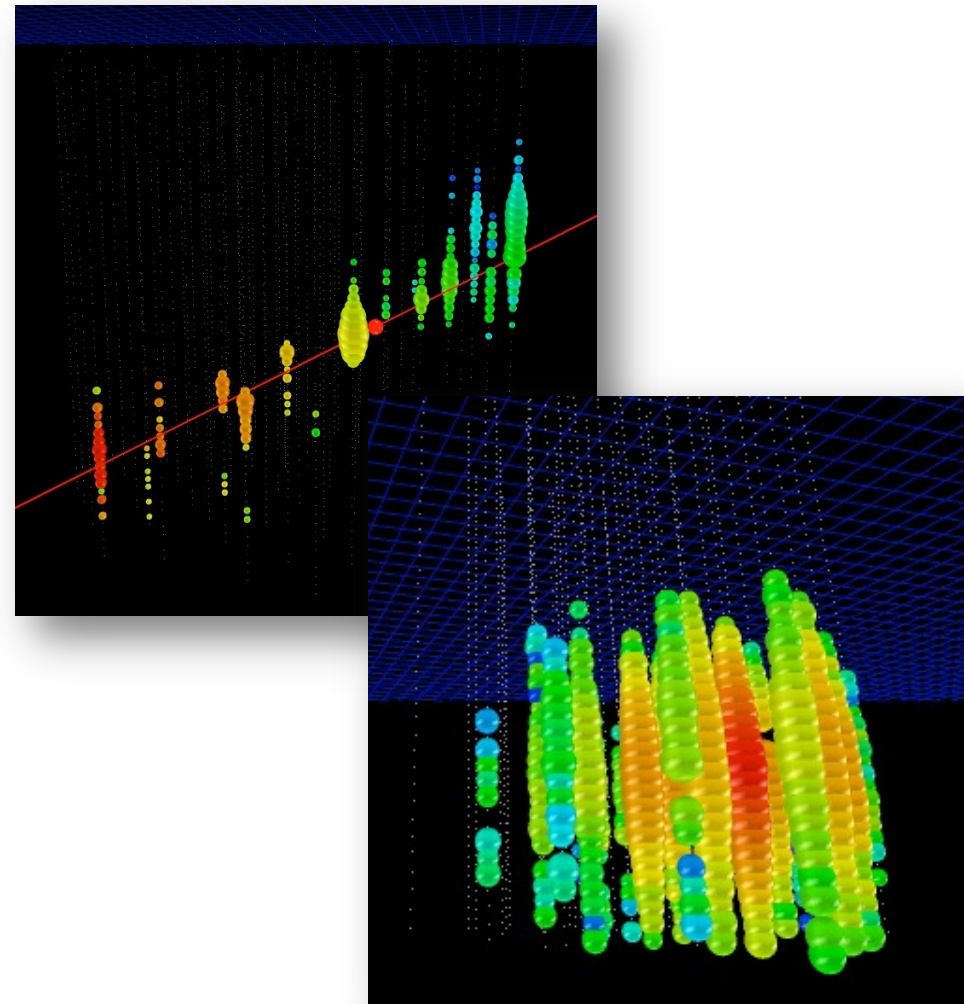

$\nu_\mu \rightarrow \mu$ Detection

- Light is mostly emitted in small bursts along muon track
- Photon arrival times, and how many there are, tell us the direction and the energy of the muon

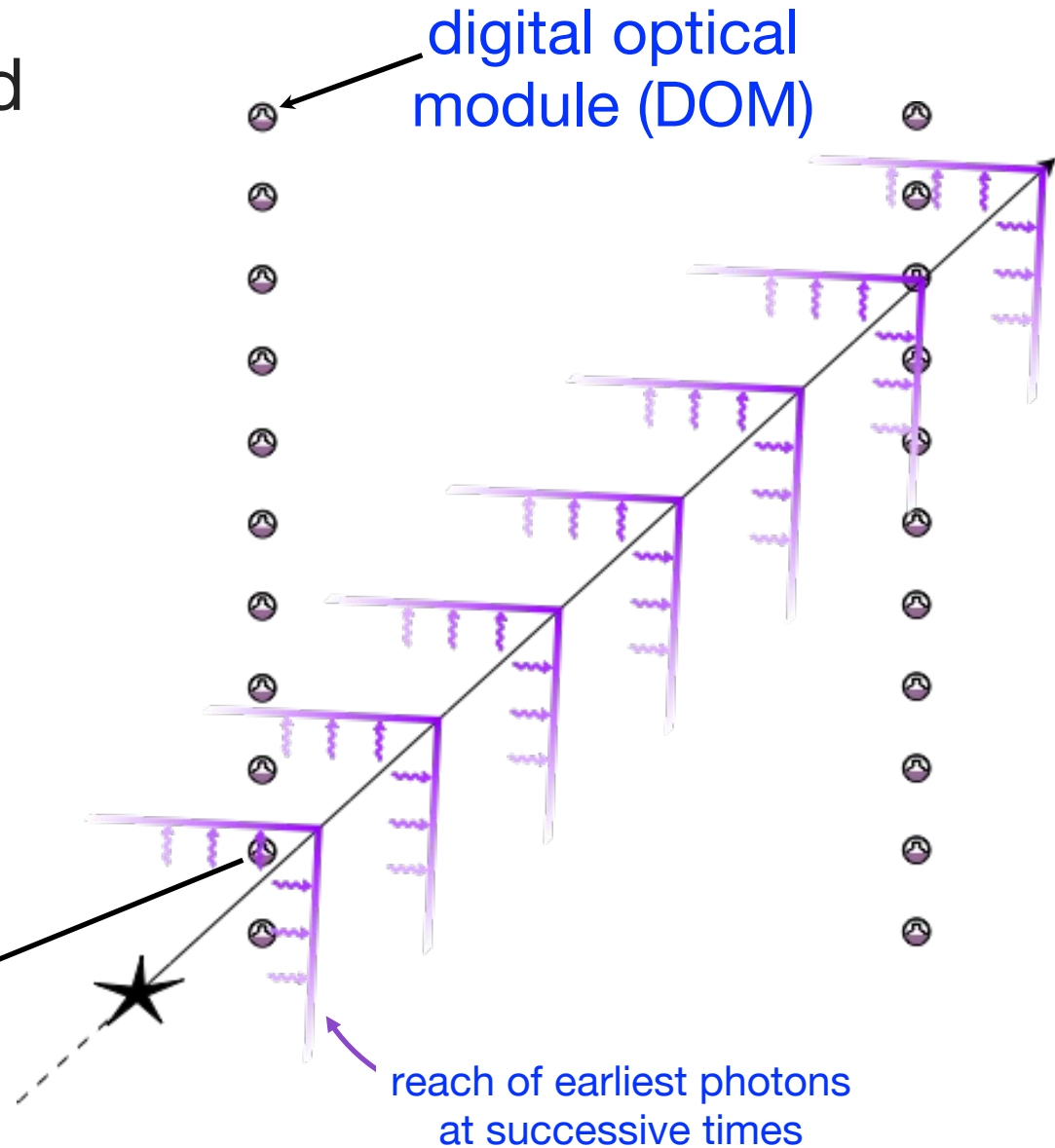
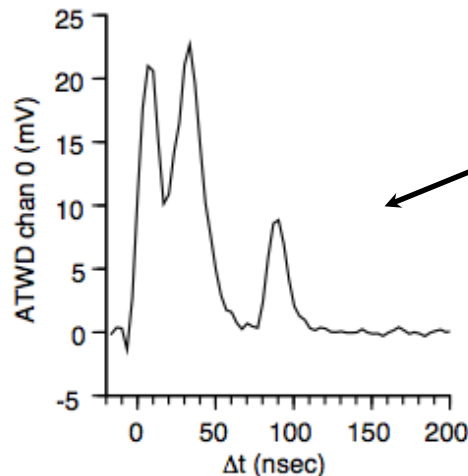

What's in a DOM?

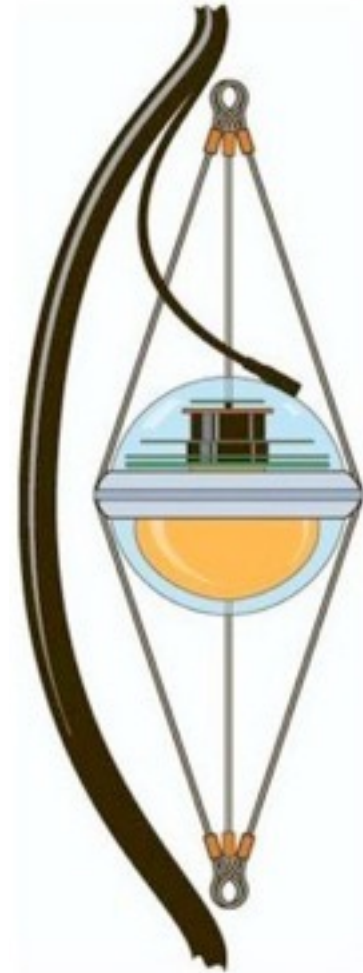
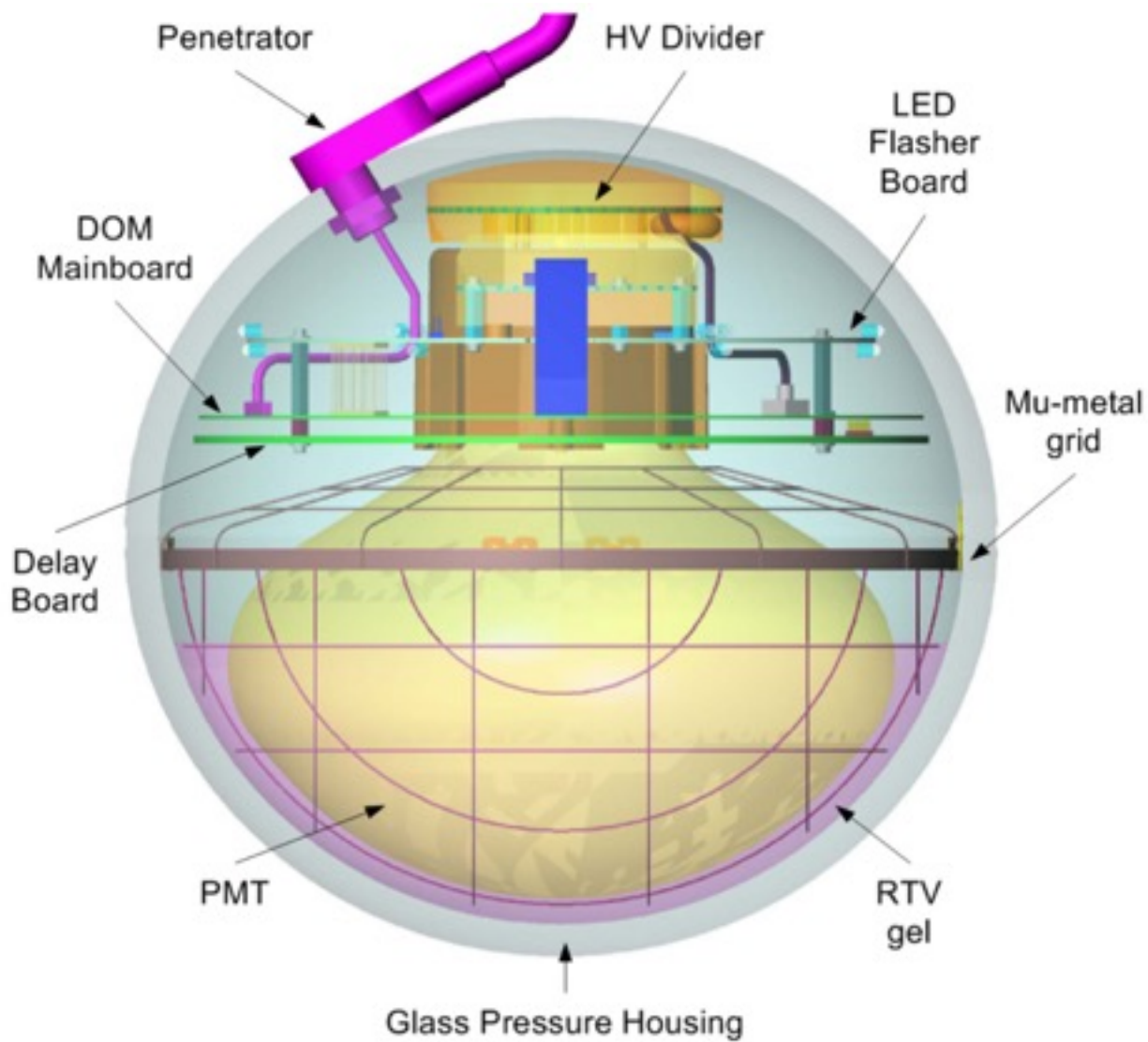

Cable: many twisted pairs, each pair carries power & communications for 2 DOMs

Photomultiplier Tube (PMT)

Typical small PMT

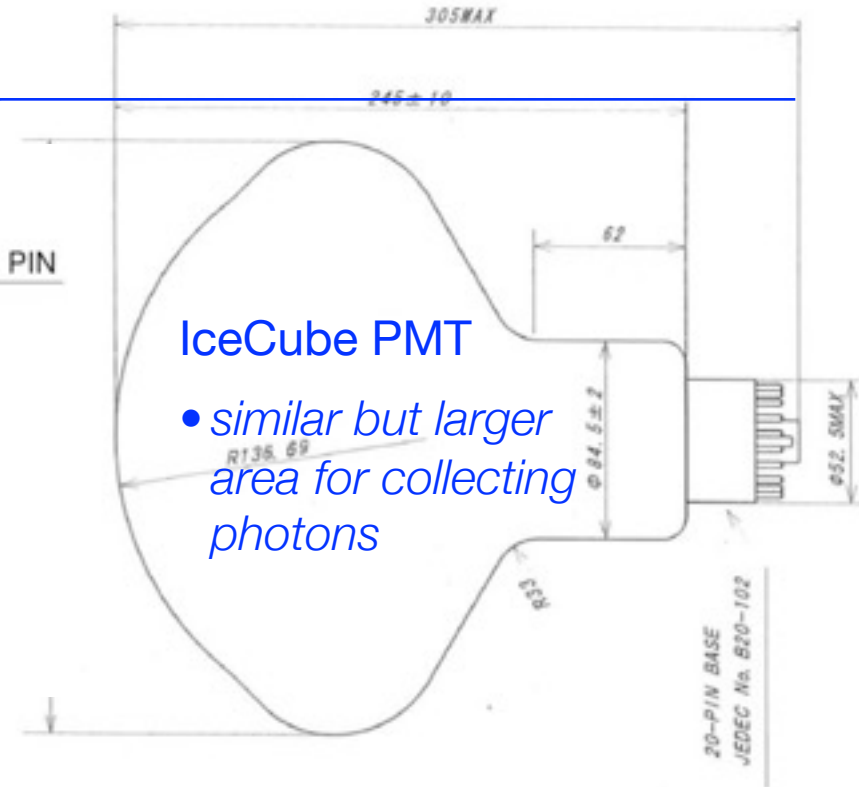
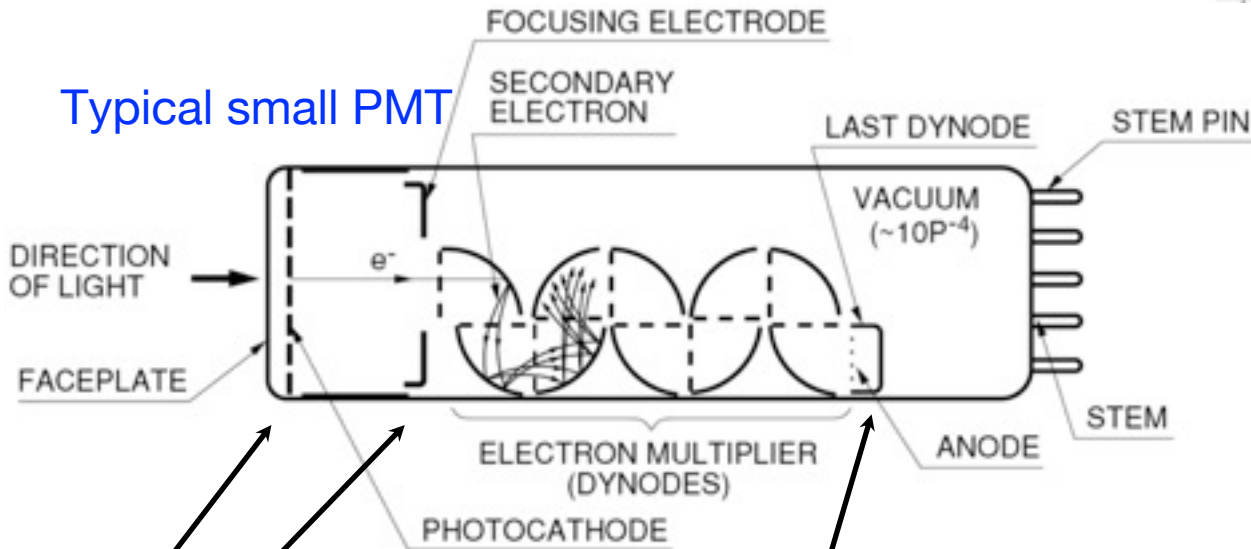

IceCube PMT

- similar but larger area for collecting photons

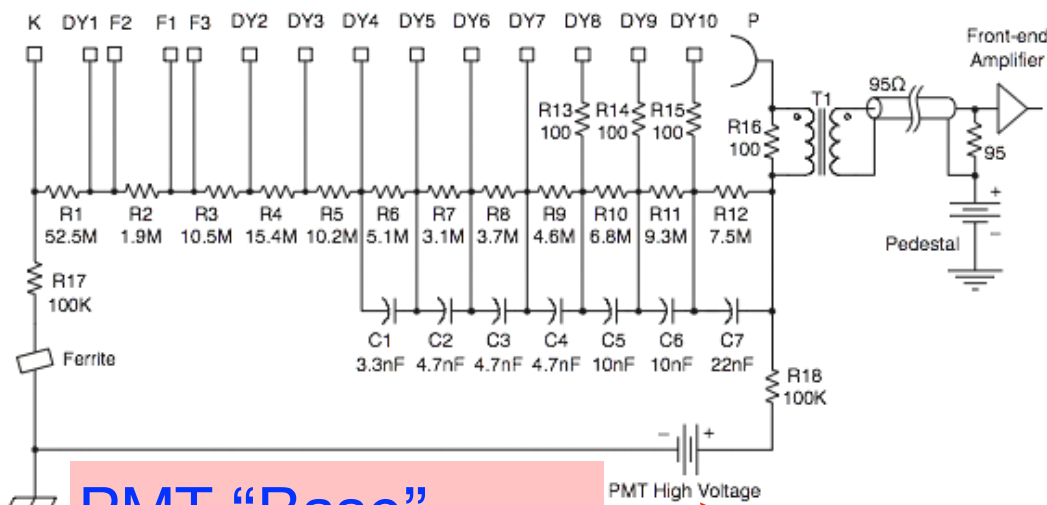

PMT "Base"
= Voltage Divider

~1500 volts

Single photon output pulse

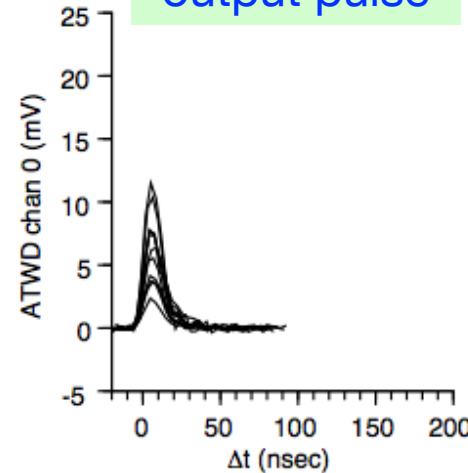

Multi-photon output pulse

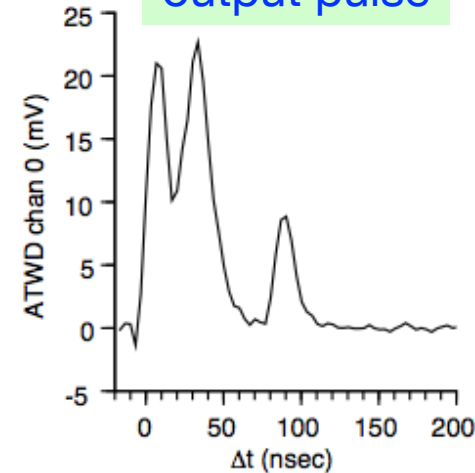

DOM signals resulting from localized light flash

- *Big differences depending on distance from source*

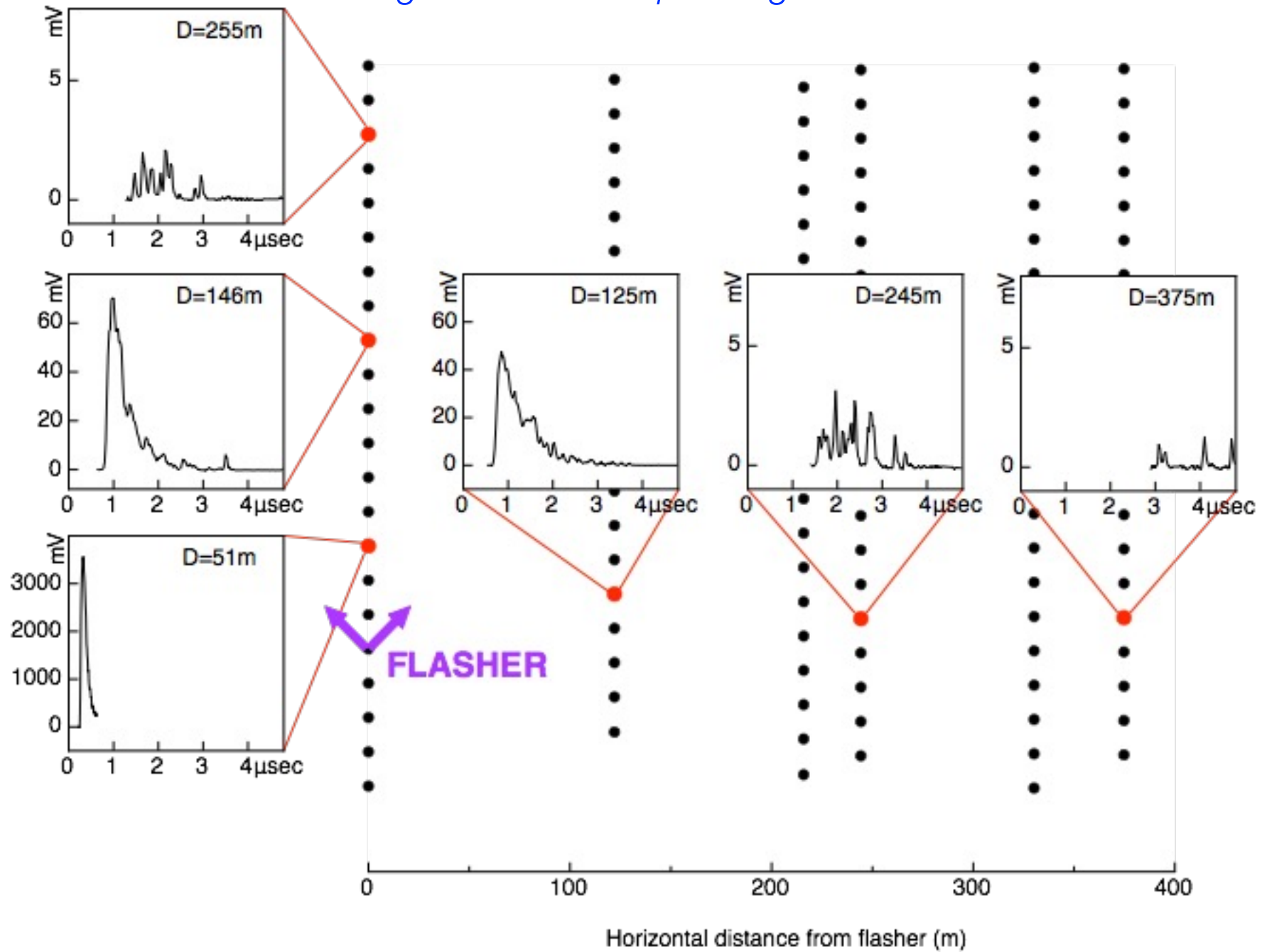

DOM Main Board

Contains waveform digitizers, on-board computer, communications circuits, HV & flasher control, etc.

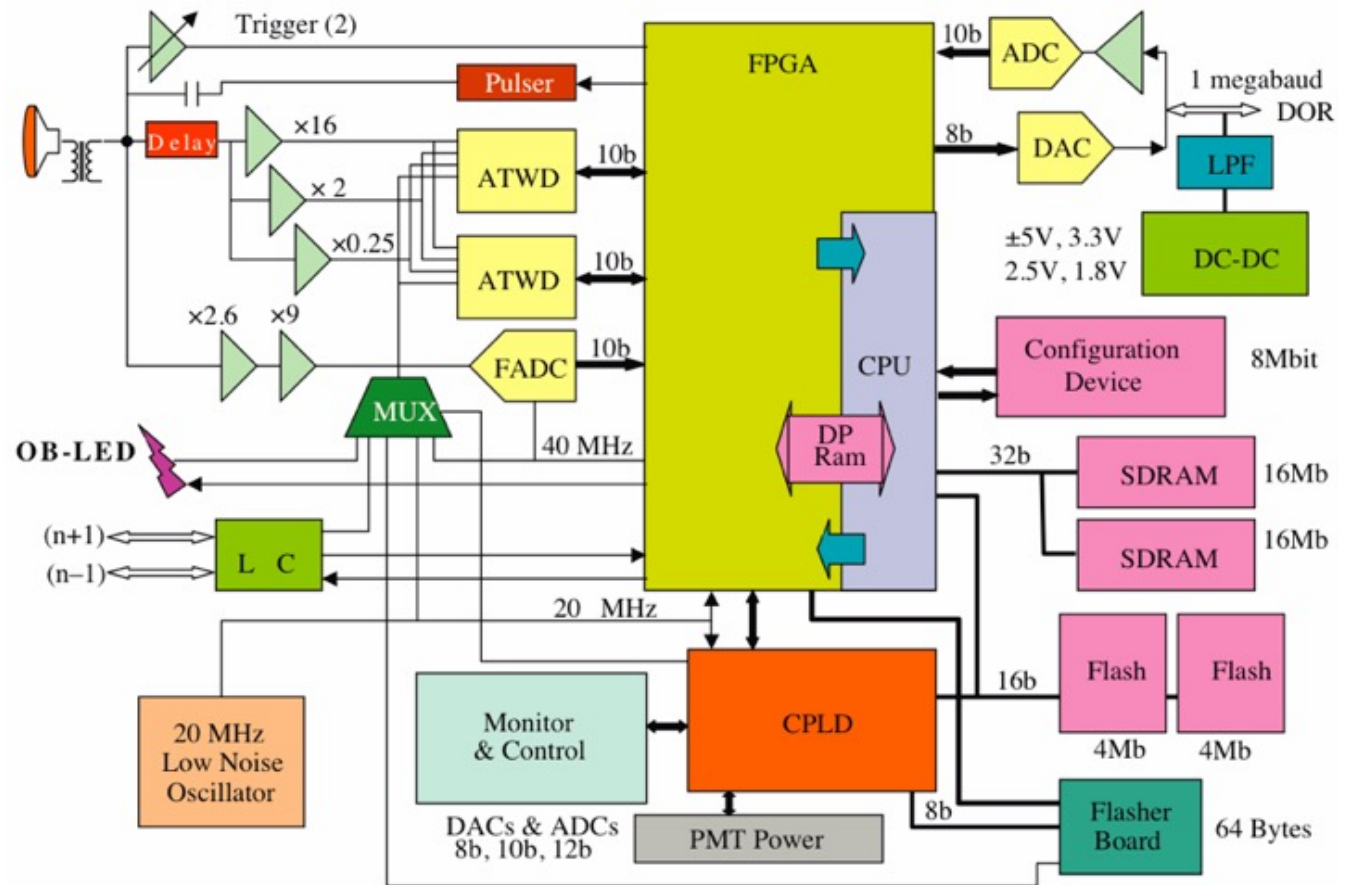

[“The IceCube Data Acquisition Subsystem: Signal Capture, Digitization, and Time-Stamping”](#)

[Nuclear Instruments and Methods in Physics Research A 601 \(2009\) 294–316](#)

<https://docushare.icecube.wisc.edu/dsweb/Get/Document-48249/>

Triggering on single photons

Actually single photoelectrons, "SPEs"

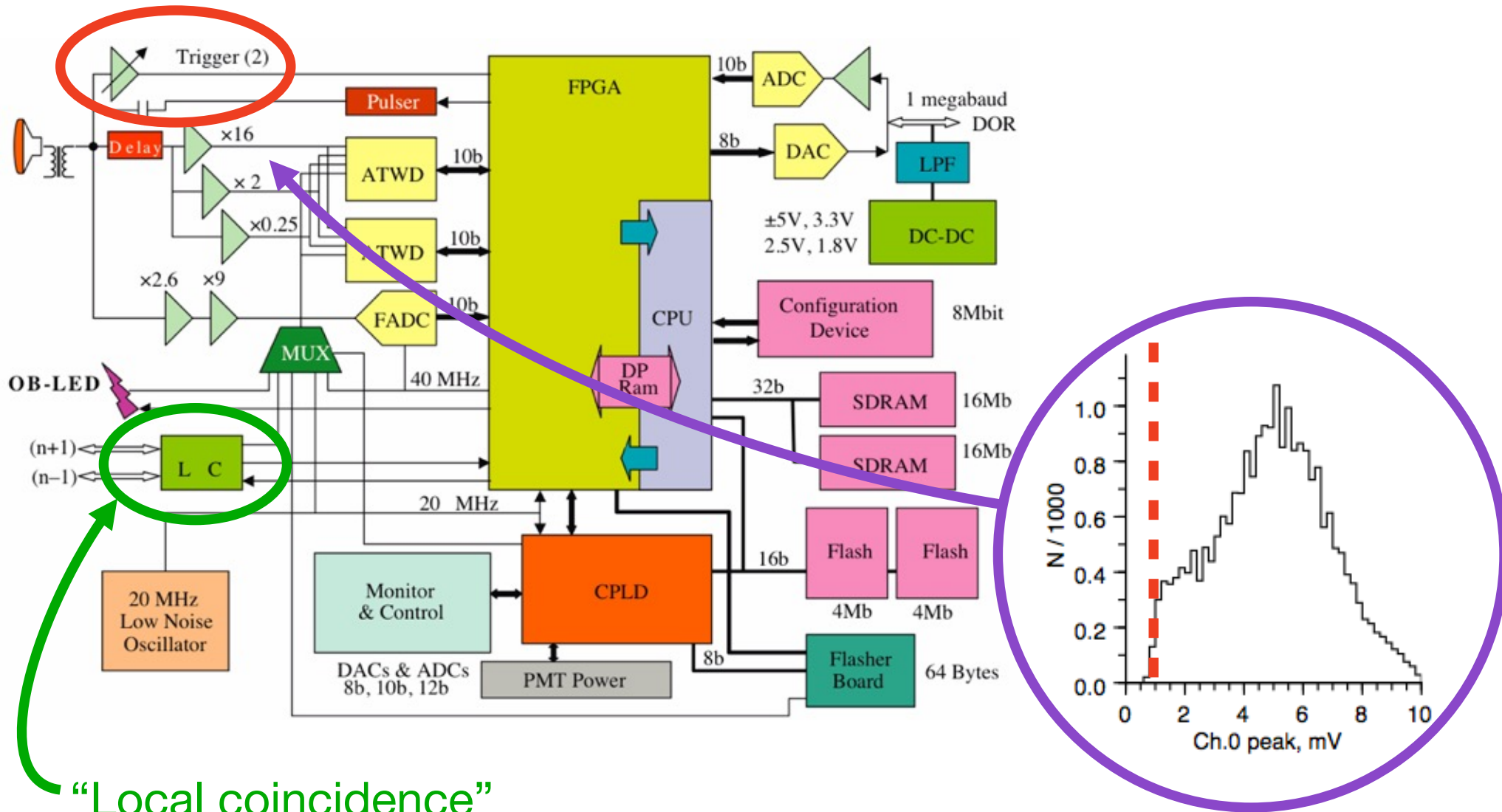

“Local coincidence”

– looks at whether a nearby DOM also recorded an SPE

Waveform recorders (digitizers)

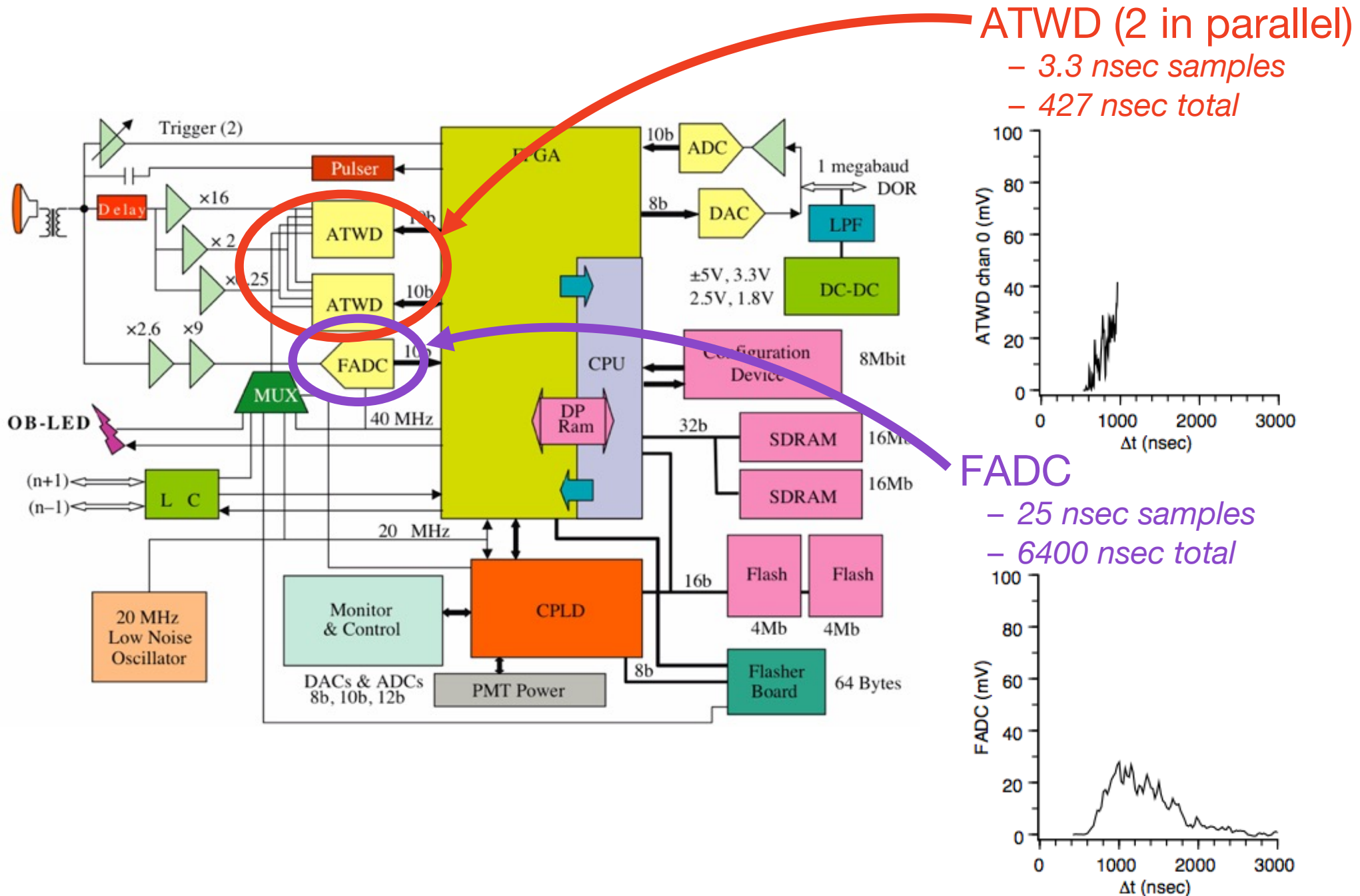

ATWD (2 in parallel)
 - 3.3 nsec samples
 - 427 nsec total

FADC
 - 25 nsec samples
 - 6400 nsec total

Waveform digitizers "ATWD" Channel 0,1,2

Different gains for small, big pulses

RAW COUNTS
0-1023

Scaled to
millivolts

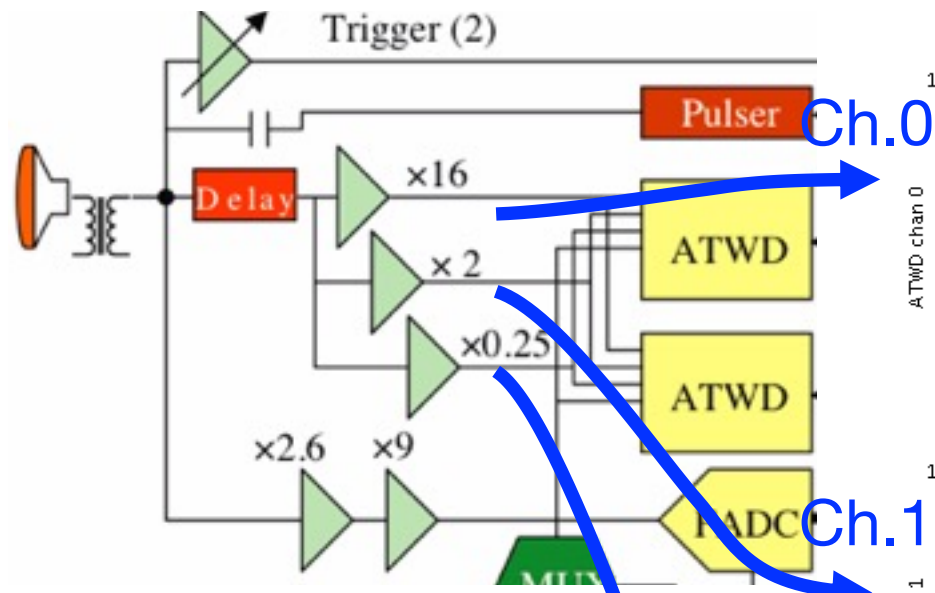

Ch.0

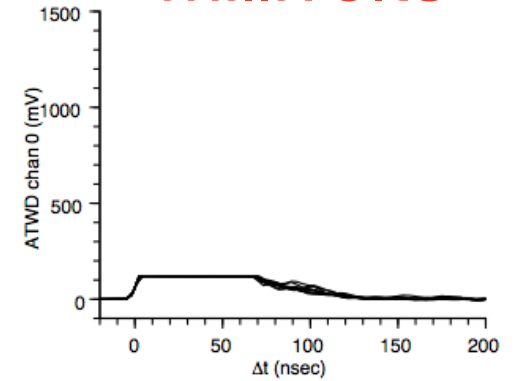
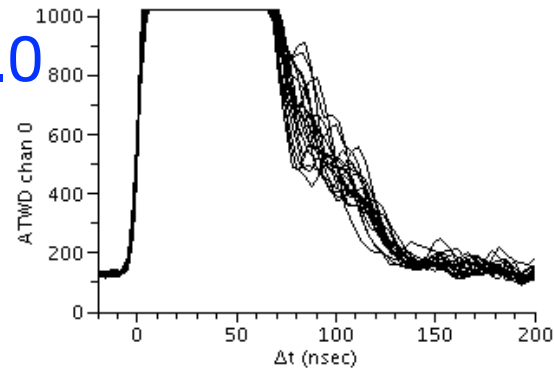

Ch.1

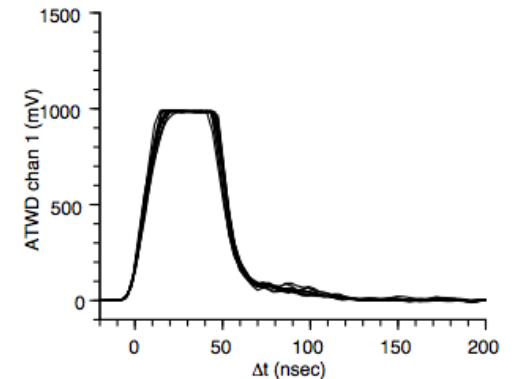
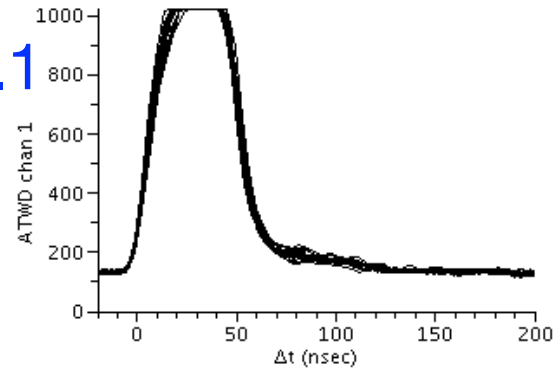

Ch.2

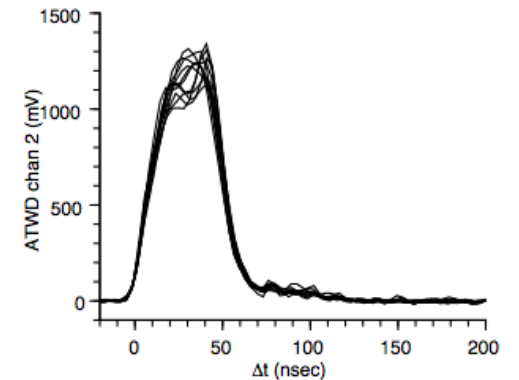
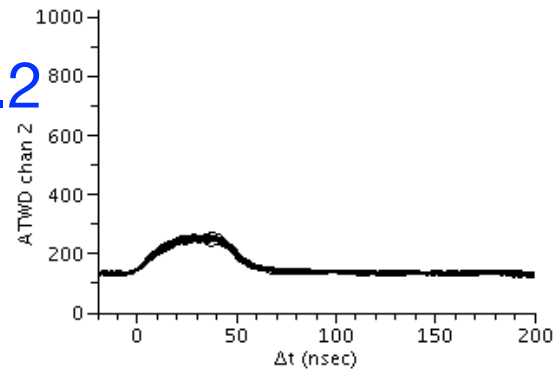

Waveform digitizers “ATWD” Ch. 0,1,2 and “FADC”

Ch.0 good for small waveforms

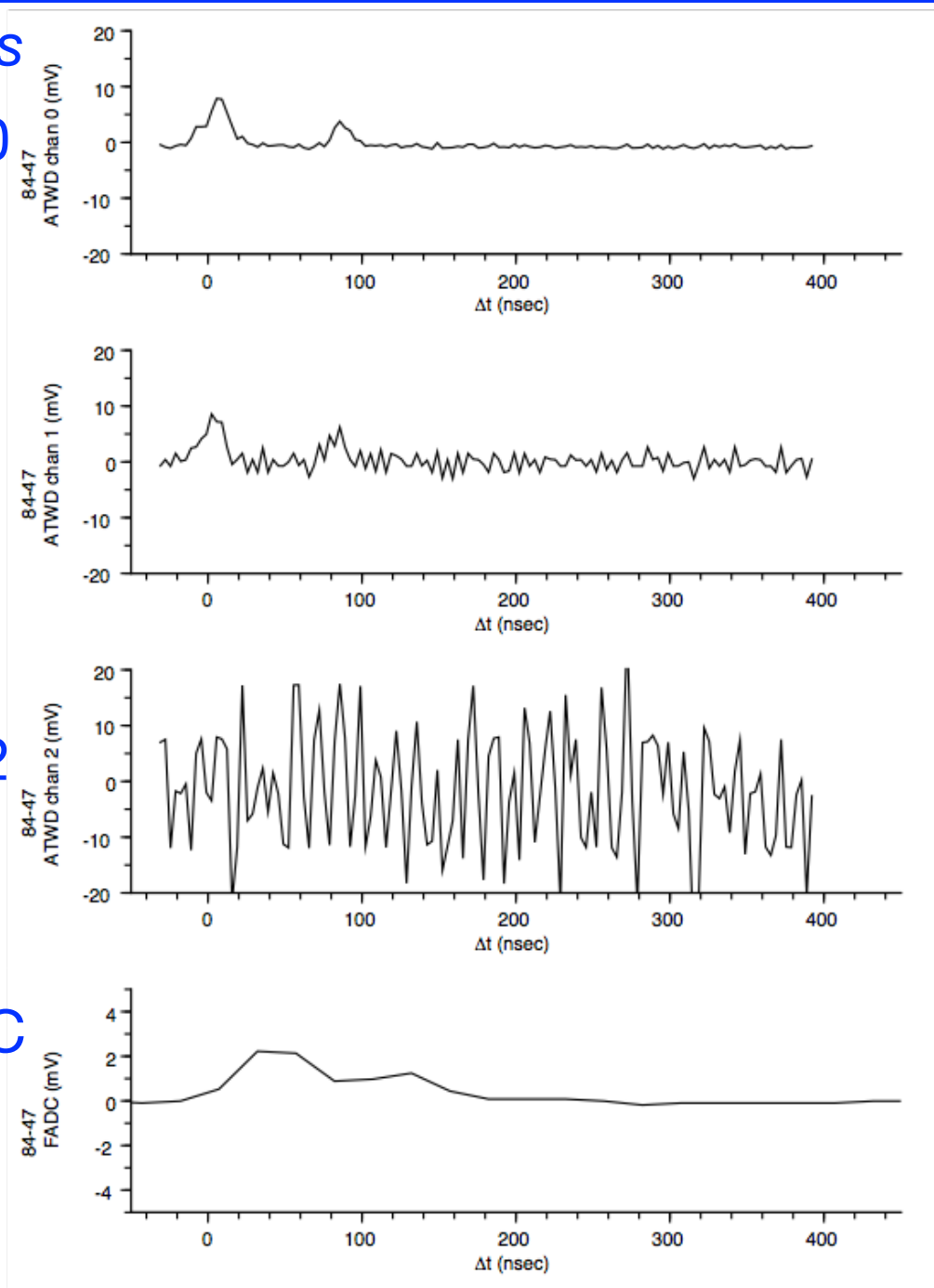
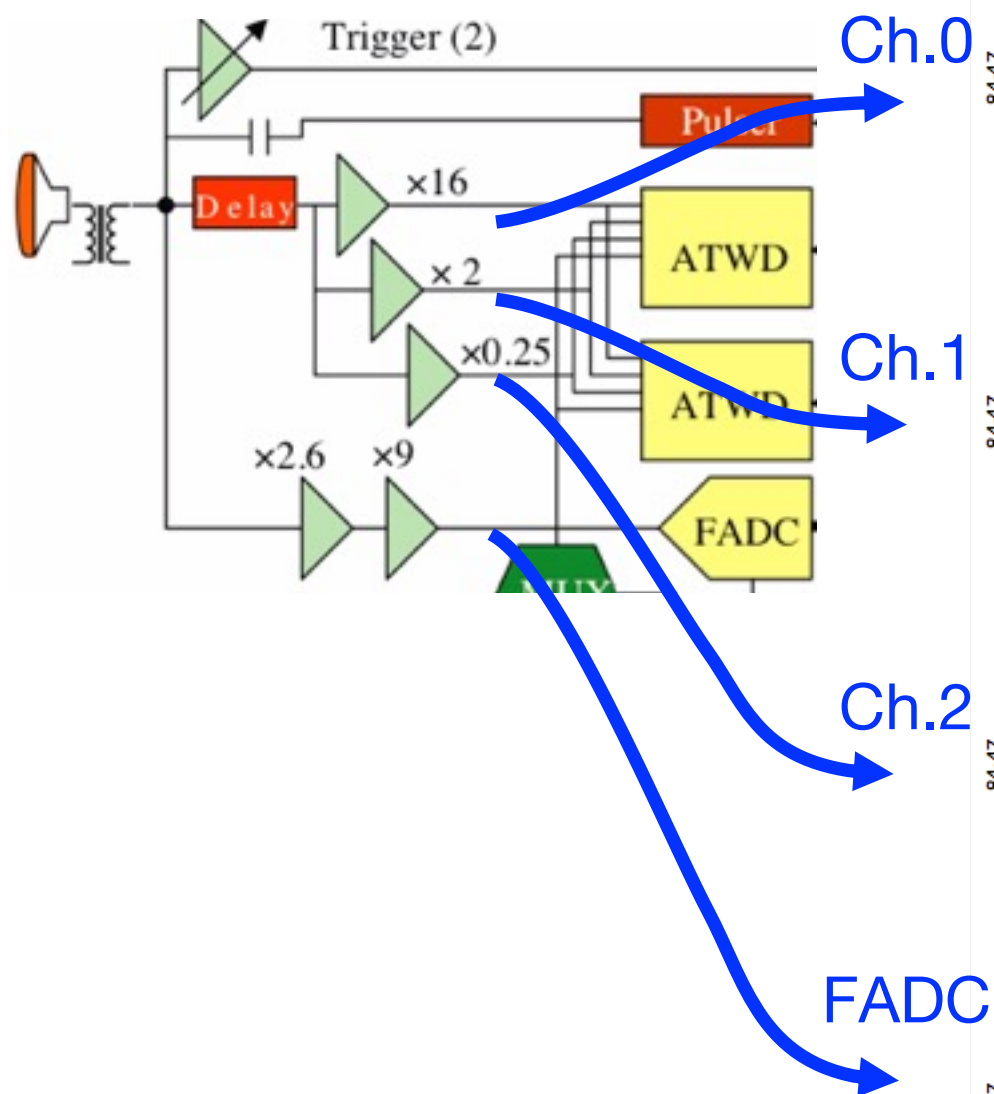

Waveform digitizers “ATWD” Ch. 0,1,2 and “FADC”

Ch.1 good for medium waveforms

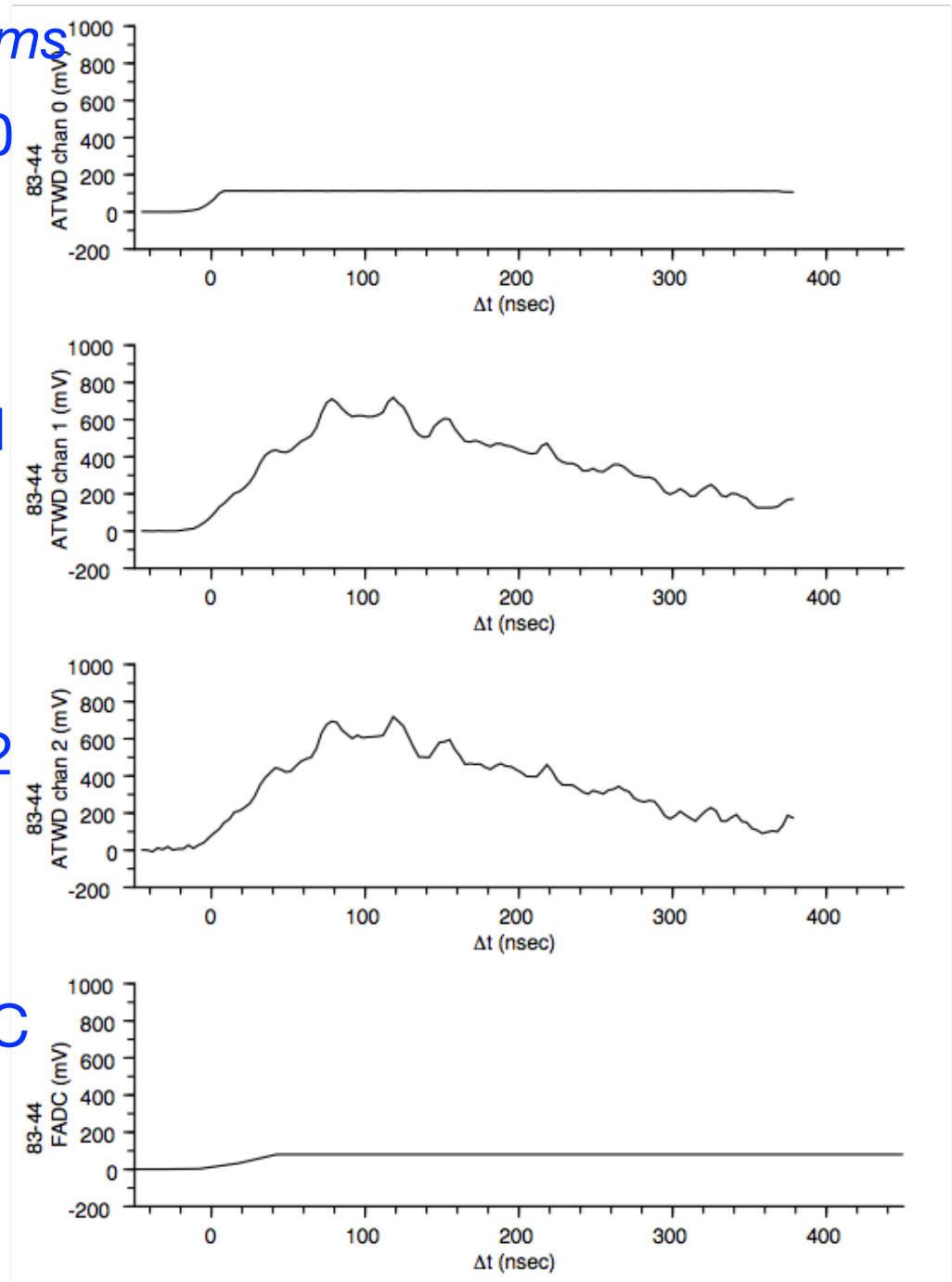
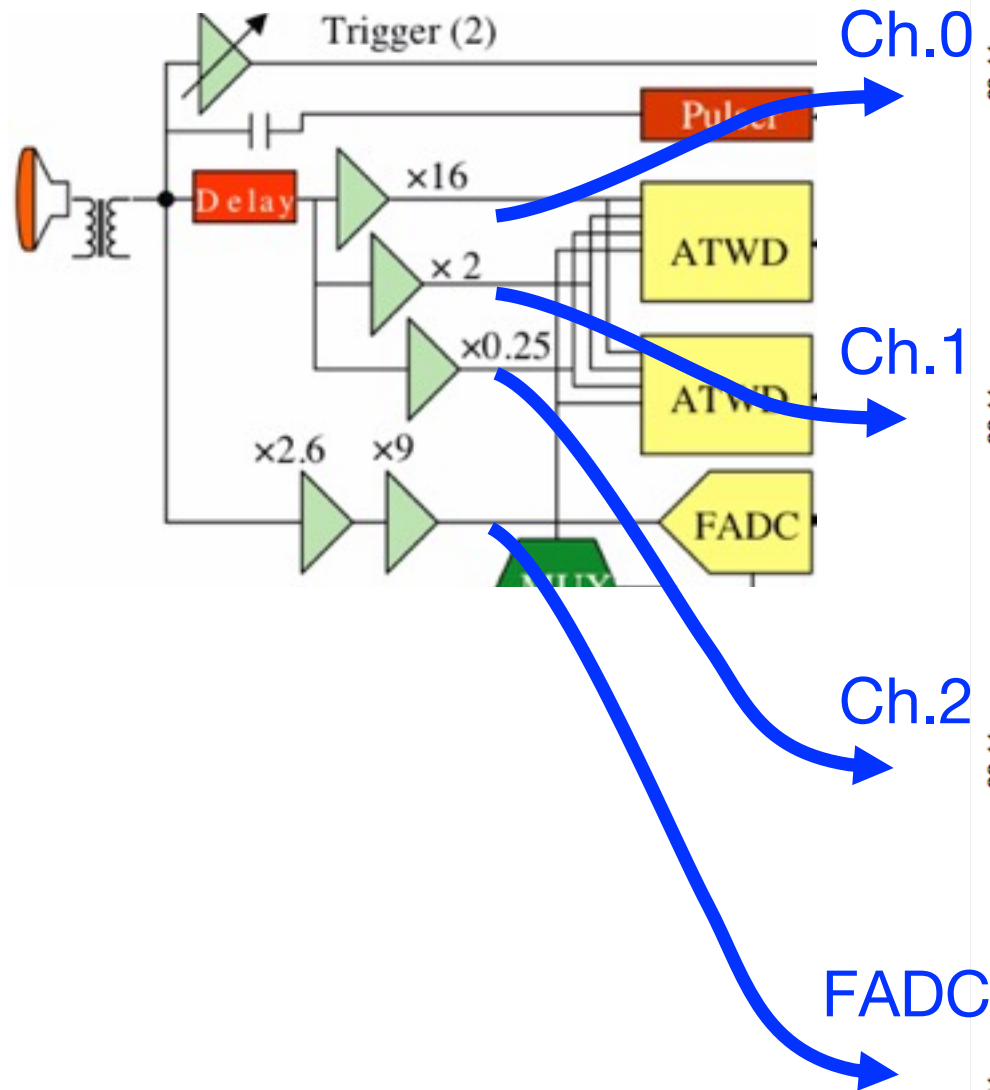

Waveform digitizers “ATWD” Ch. 0,1,2 and “FADC”

Ch.2 needed for large waveforms

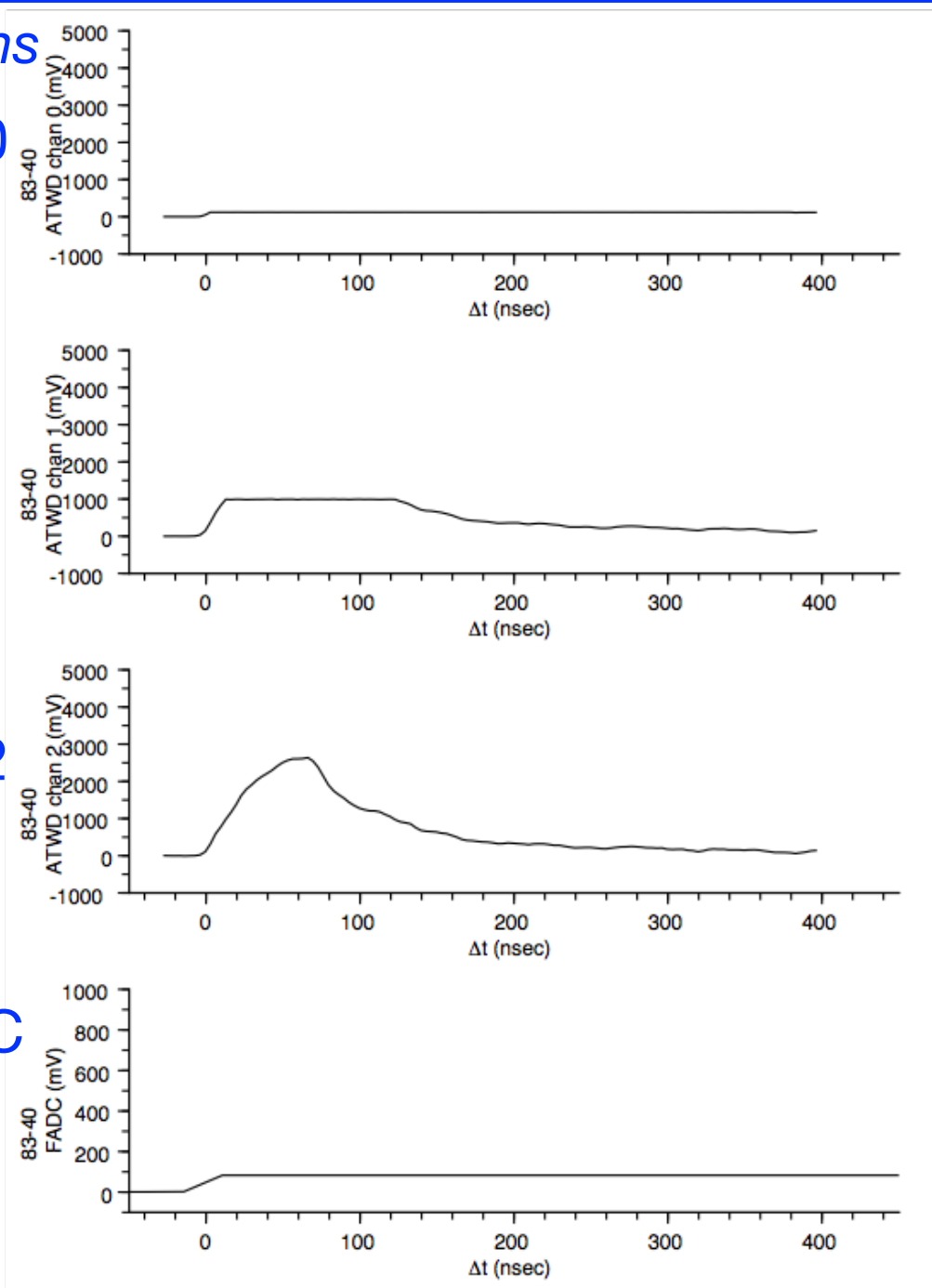
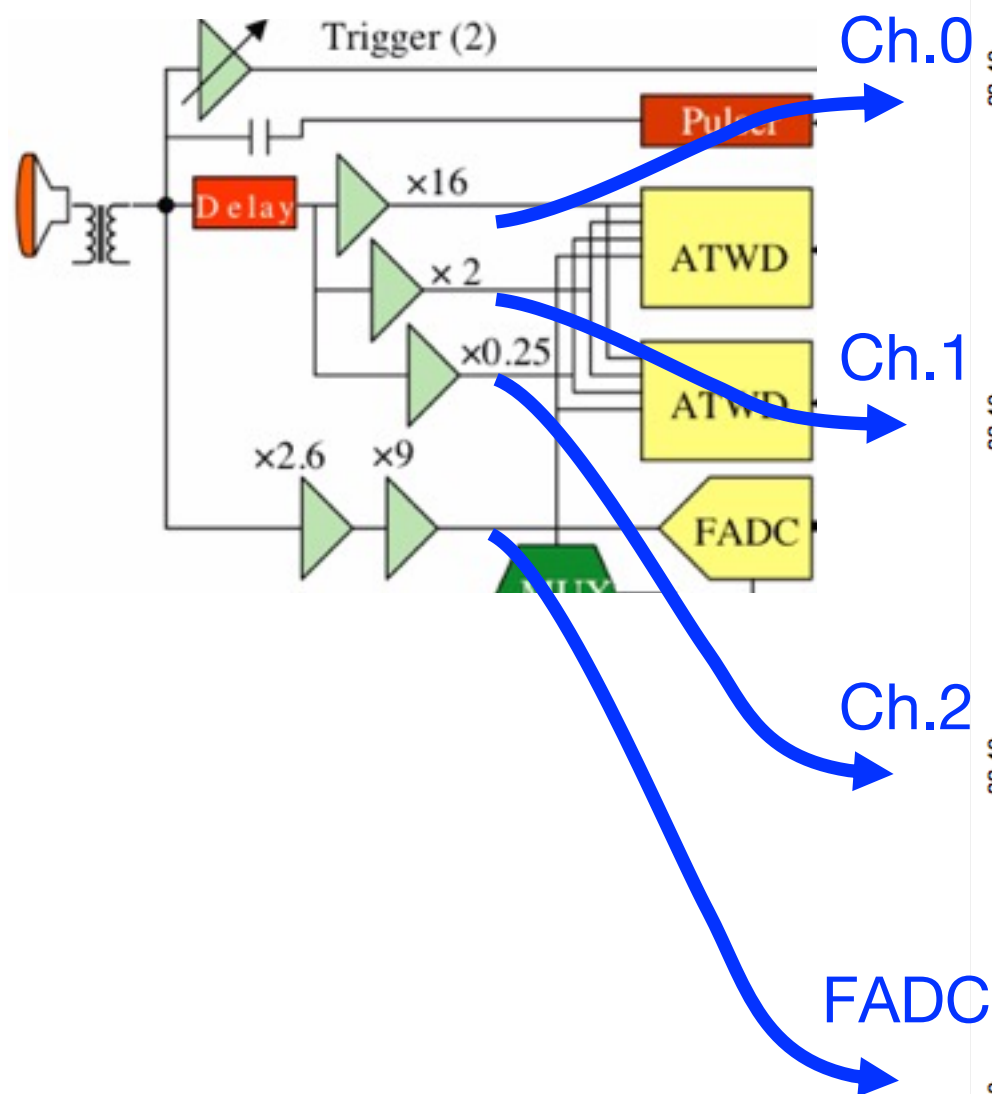

Waveform digitizers “ATWD” Ch. 0,1,2 and “FADC”

FADC needed for long waveforms

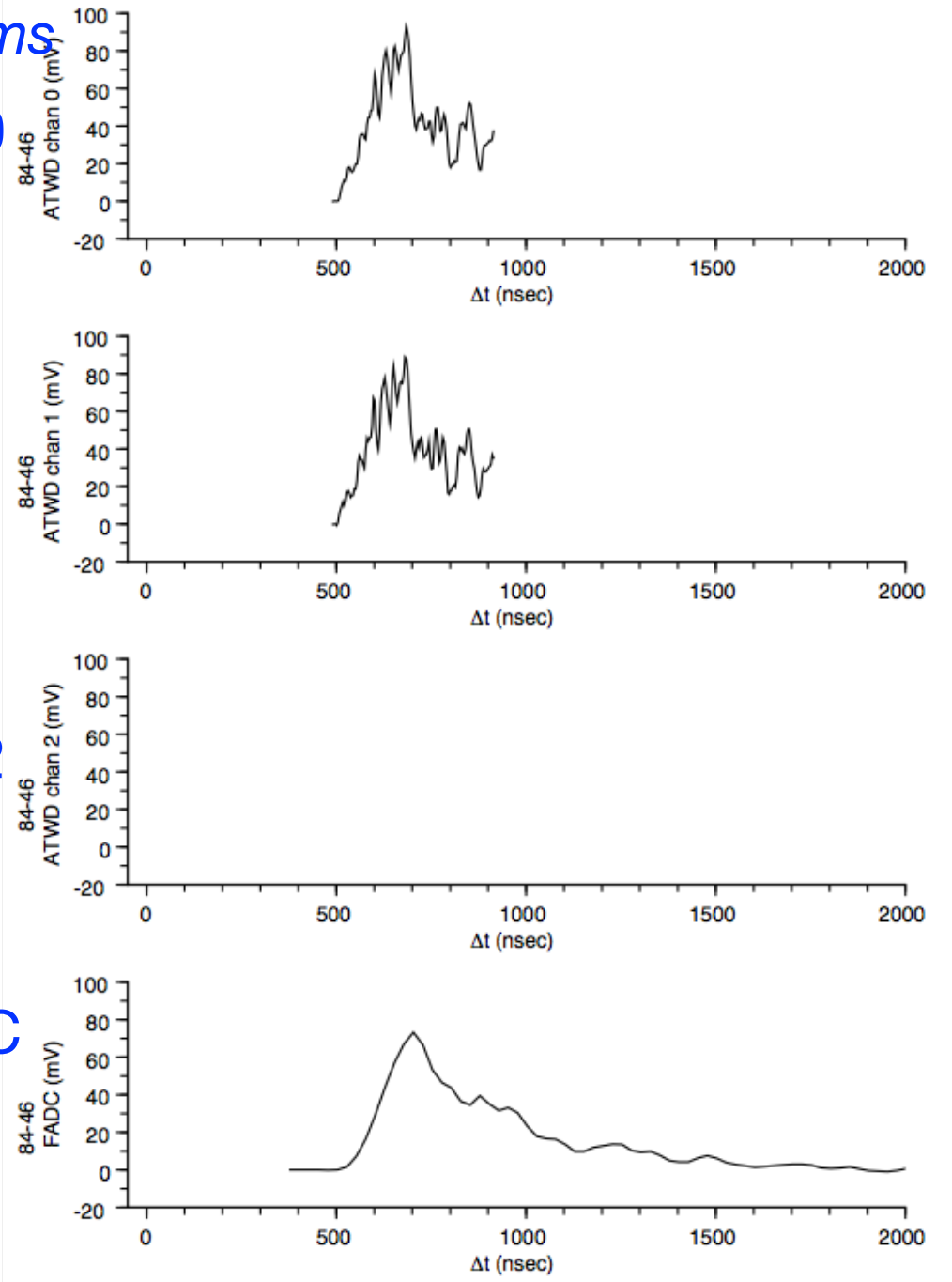
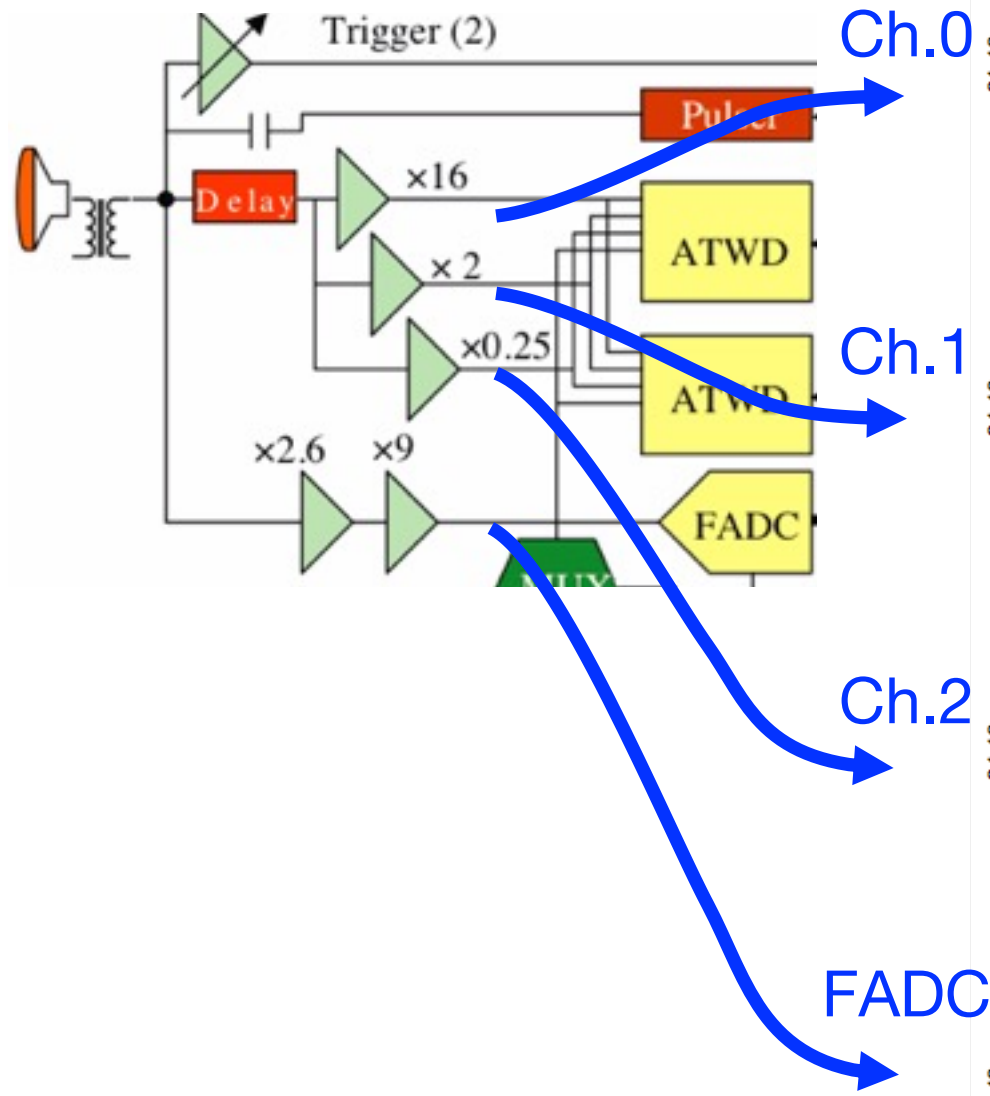

Sending waveforms to surface

Connection to surface via main cable

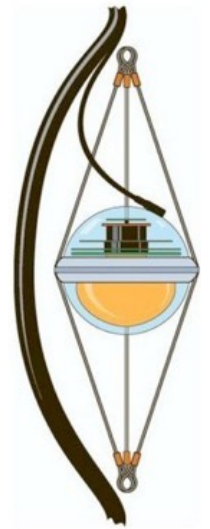
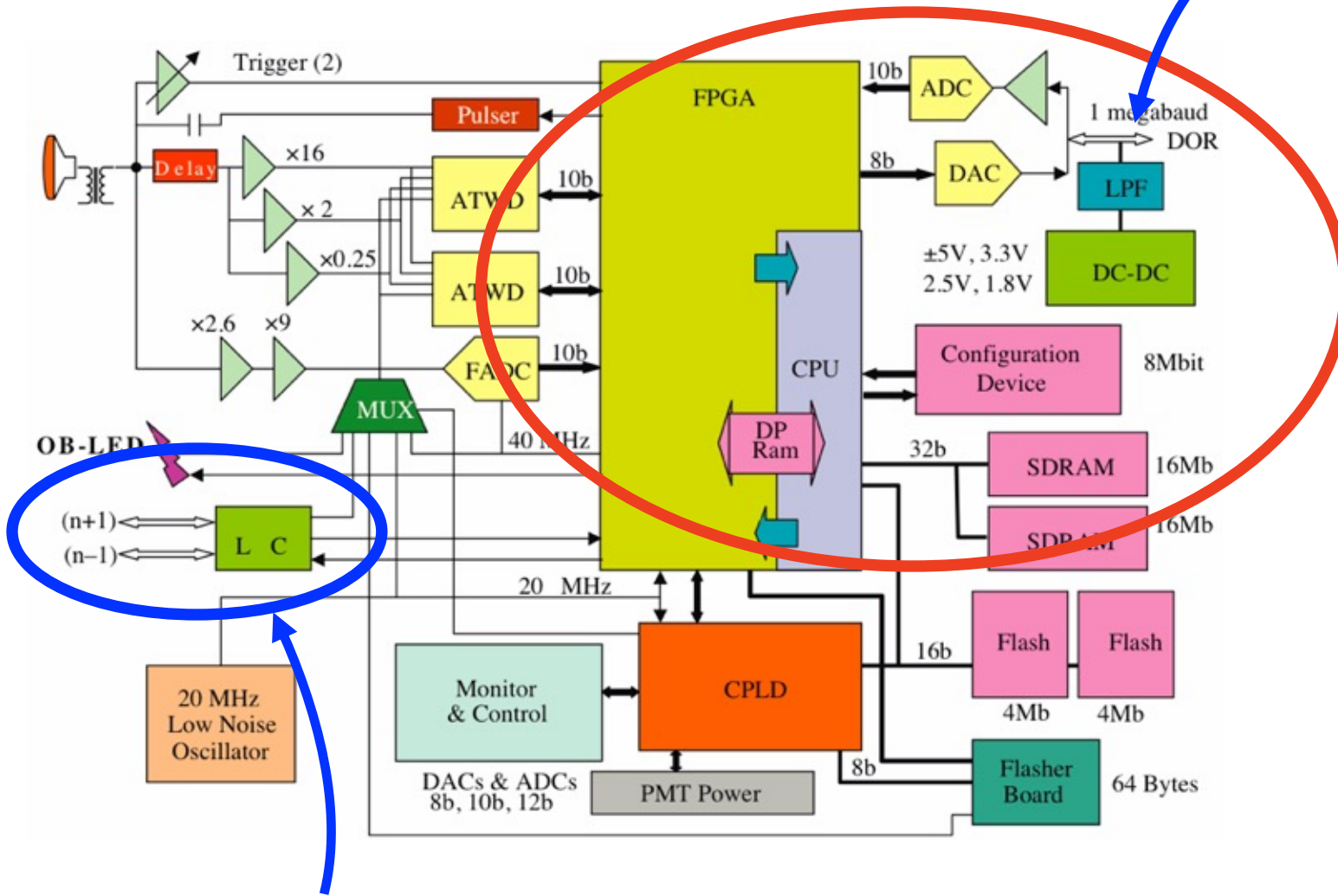

Connection to neighbor DOMs via main cable

Local Coincidence

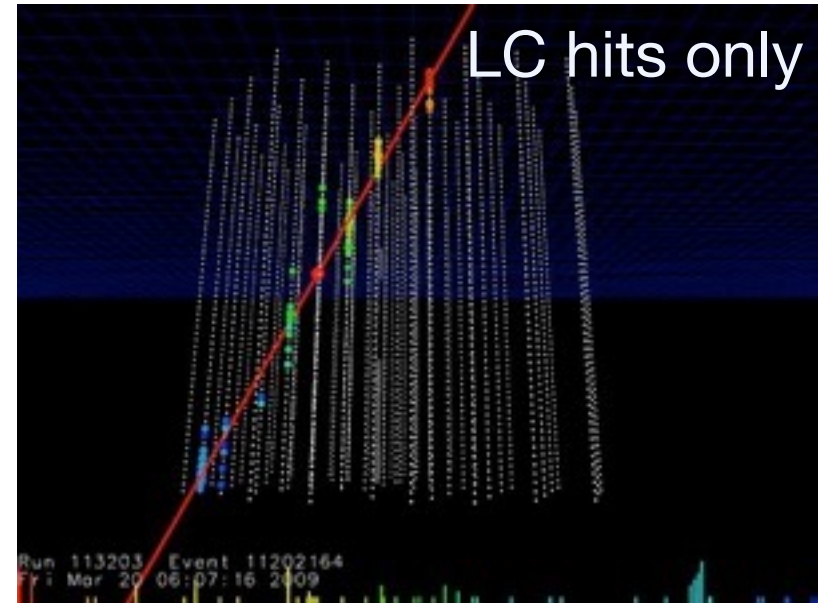
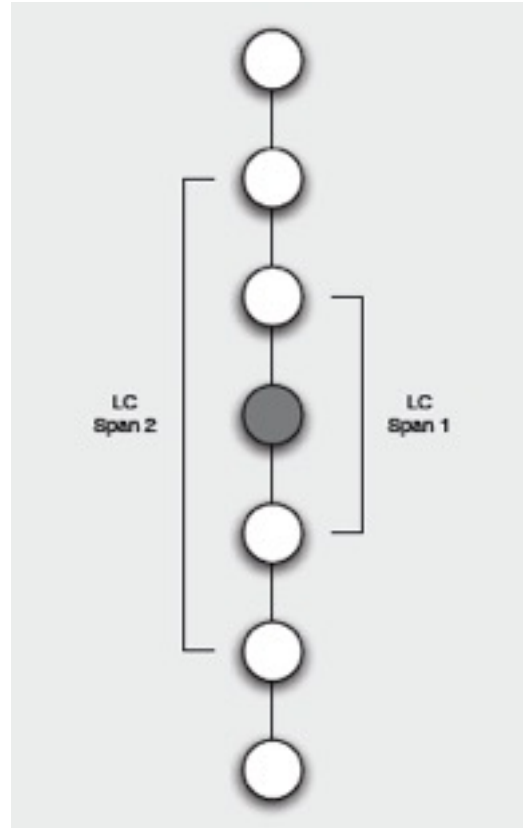
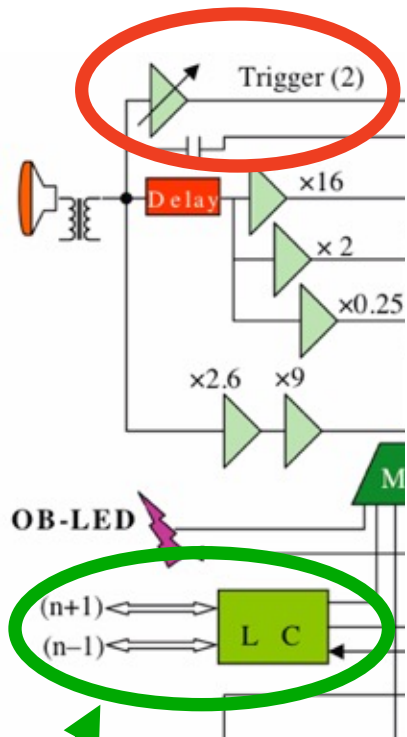

“Local coincidence”

- looks at whether a neighboring DOM also recorded an SPE
- 1 μ sec time window implemented in FPGA
- Many no-LC hits are from PMT dark noise, others are isolated signal photons

Sending waveforms to surface

- Readouts *with* local coincidence “HLC Readouts”

- Ch.0 + FADC
- Ch.0 + Ch.1 + FADC
- Ch.0 + Ch.1 + Ch.2 + FADC

Include enough channels to accommodate peak amplitude

*Highly compressed ~150 bytes/record
but all information is saved*

- Readouts *without* local coincidence “SLC Readouts”

*Only three samples of FADC are saved
so time of SPE can be determined*

- All readouts are grouped into big chunks and transmitted to surface
- Must stay below 40kB/sec for each DOM, otherwise chunks of data get thrown away (“LBM overflows”)

Data flow and reduction

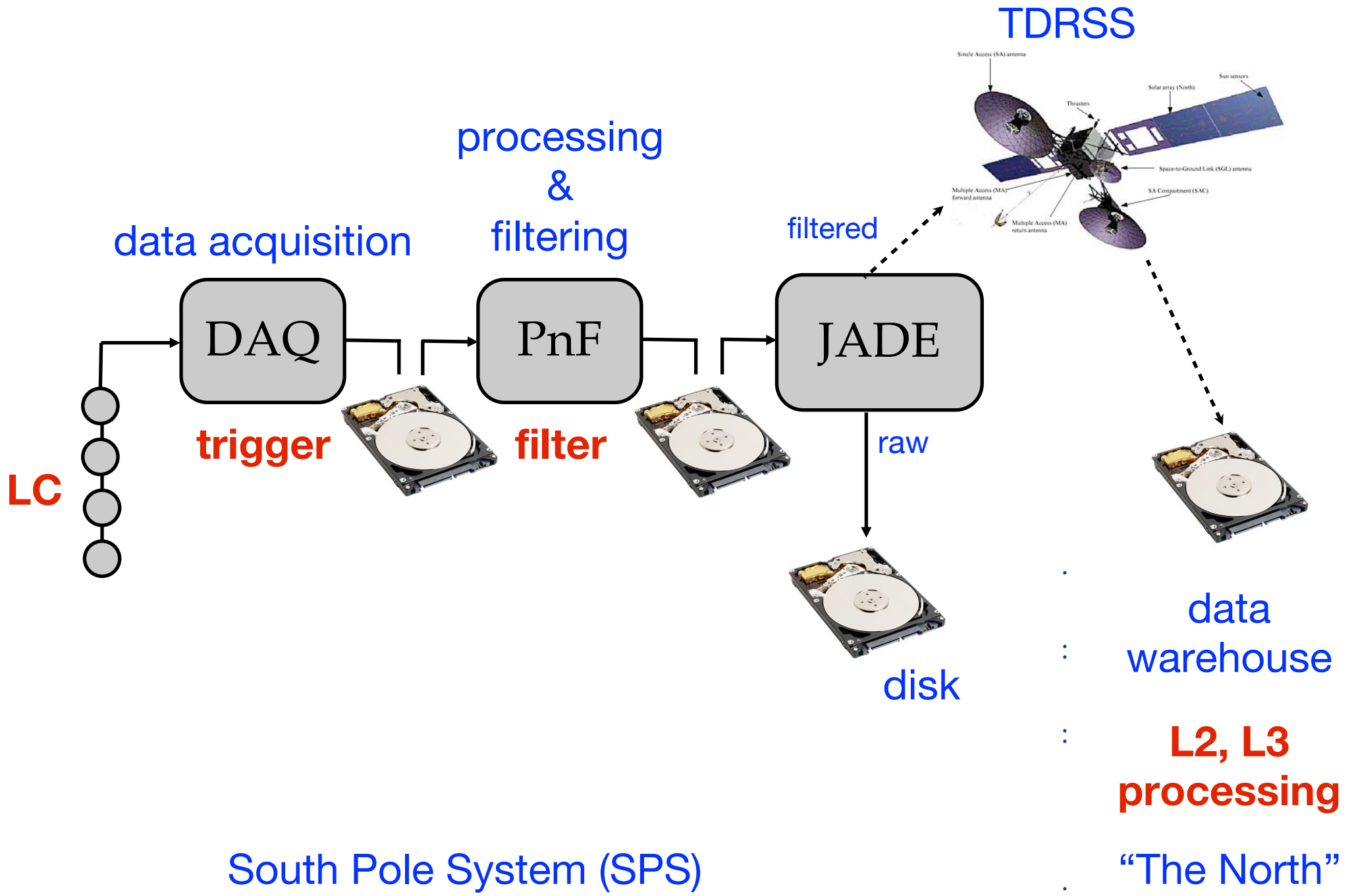

DAQ (Data Acquisition System)

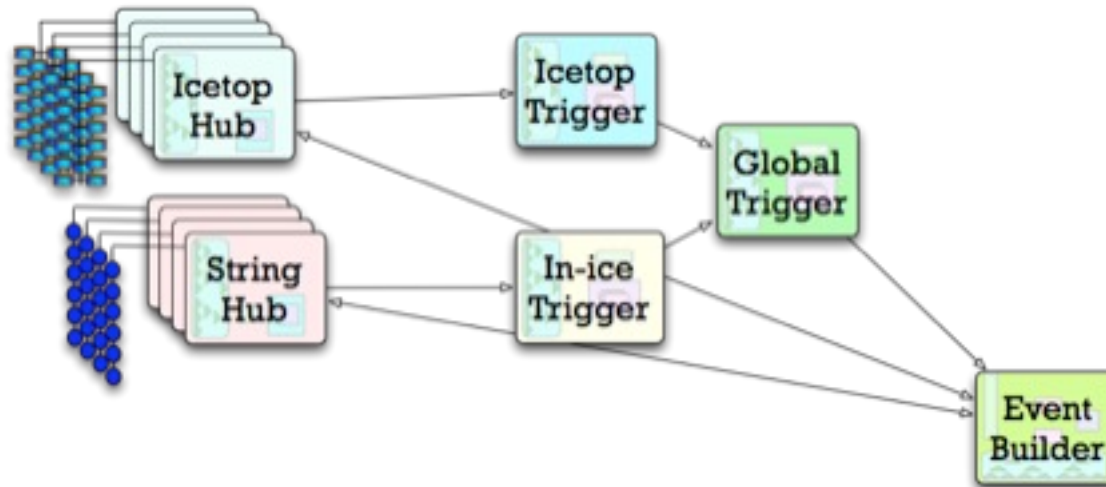

- DOMs generate **hits**: PMT waveform(s) + a timestamp
- We don't want to (and can't) save every hit from every DOM all the time
 - but we do save them for ~12 days in *hitspool* buffers
- The DAQ forms **triggers** when a pattern of hits looks interesting
 - many definitions of “interesting”: muons, cascades, air showers, monopoles...
- Individual triggers are combined into a global readout window, or “event”

Simple Multiplicity Trigger

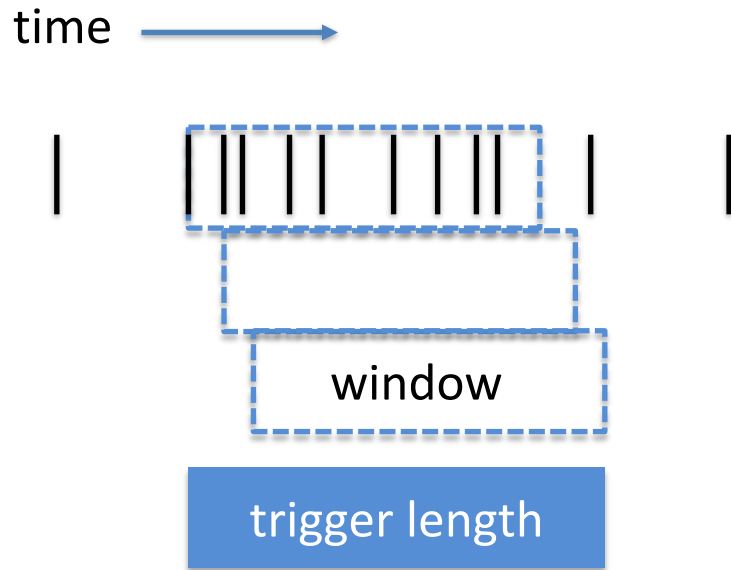

- At least N HLC hits in a sliding time window
- Trigger is extended as long as majority condition satisfied
- Readout windows extend both sides; capture early, late light and SLC hits

Sub-detector	HLC hits	Window (μs)	Rate (Hz)
In-ice	8	5	2100
DeepCore	3	2.5	250
IceTop	6	5	25

Example global trigger

Real data from 2011

(trigger time, trigger length) in ns

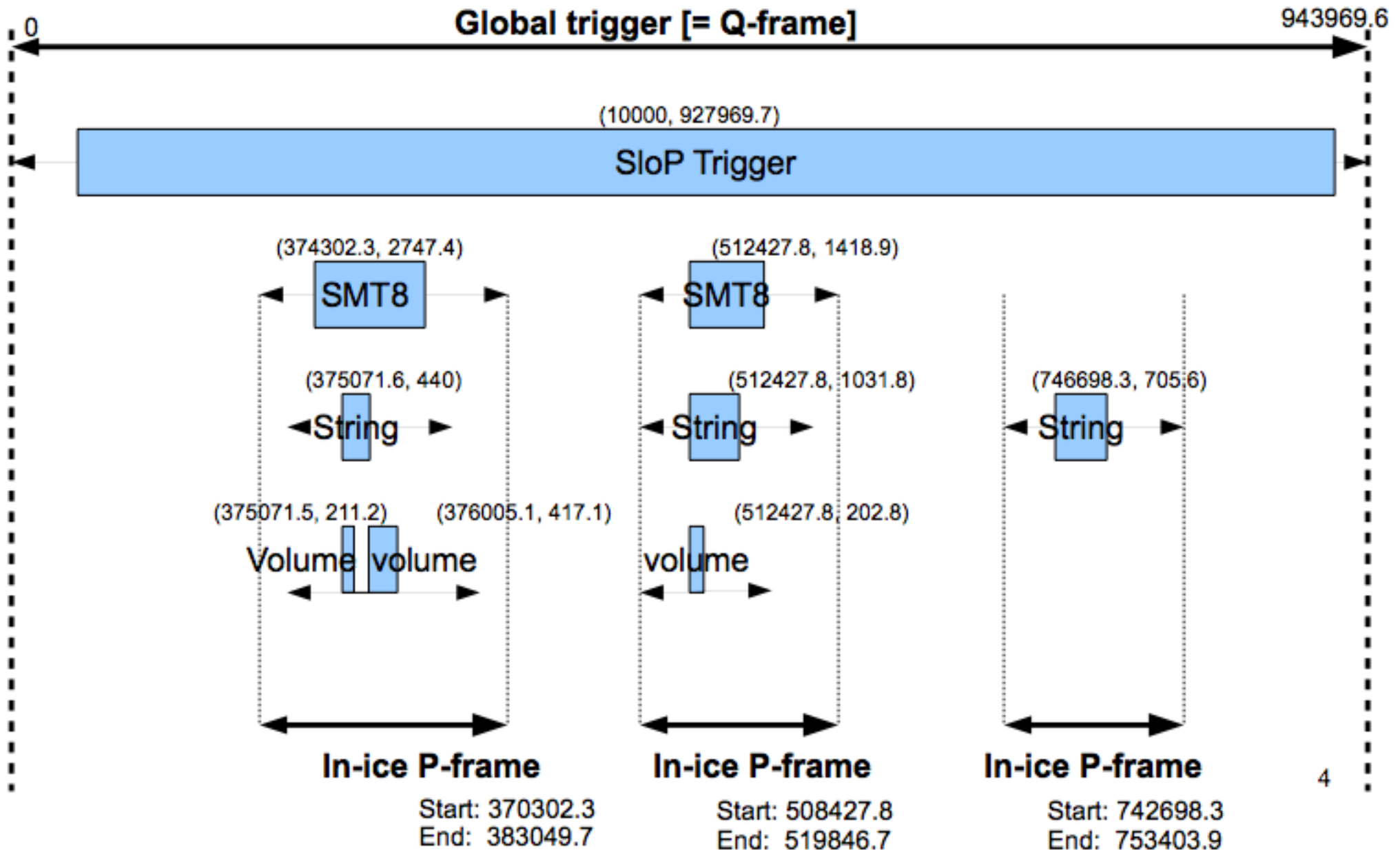

SNDAQ

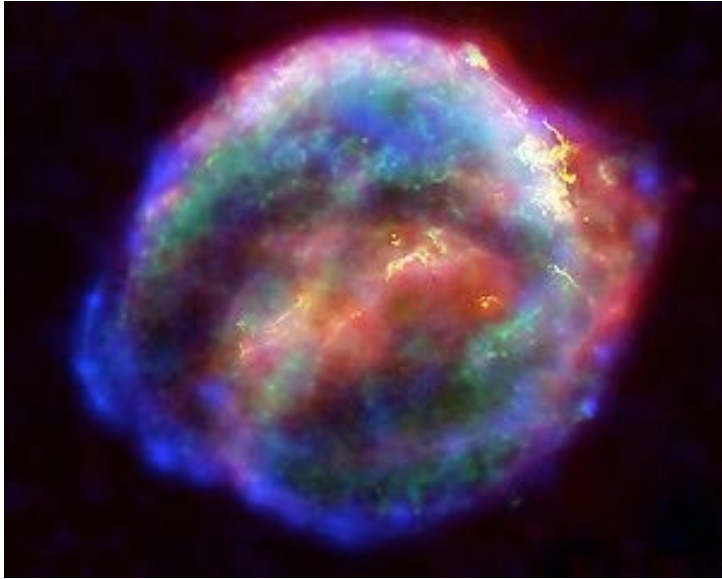

- IceCube can also detect nearby supernovae: detection method very different

- The **Supernova DAQ** runs in parallel to the “normal” DAQ after the StringHubs

- Collects noise rates vs. time for all in-ice DOMs

- looks for global rise in noise rates across detector
- sends alerts over Iridium satellite constellation to SNEWS
- sends SMS alerts and e-mails

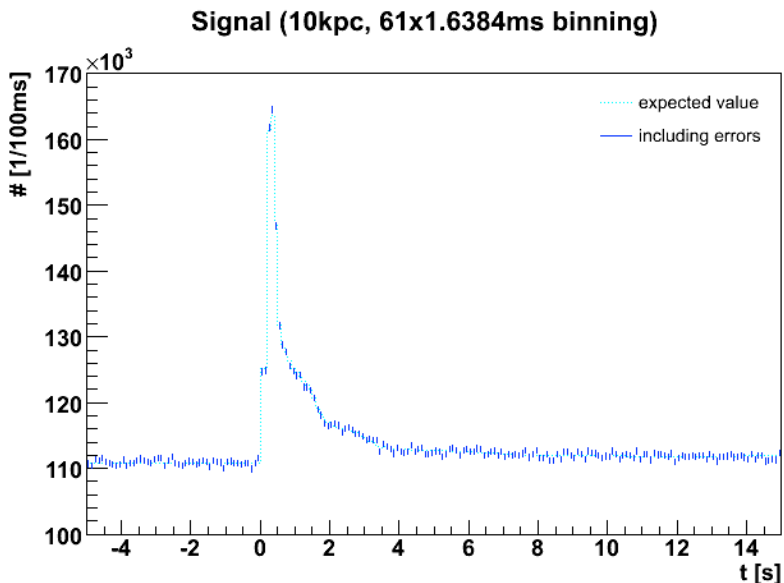

Online Filtering

- DAQ “raw” output: almost 1 TB/day
 - recall: vast majority of these are cosmic-ray muons
- TDRSS (satellite) bandwidth allocation for IceCube: 105 GB/day
- Options:
 - wait until we can fly the disks out (what if there’s a problem with the data?)
 - run **filtering** online to look for interesting events; send subset of data over satellite
- **Bonus!** Can trigger other experiments for near-real-time followup
 - HESE, EHE, optical / gamma-ray followup alerts

What is a filter?

- A **filter** is the first stage of analysis that looks for a type of physics event at SPS, to send over the satellite
- Each working group proposes its own filter(s): muon, cascade, etc.
- The filters are run by **PnF**, which calibrates and cleans the data, looks for events containing triggers that the filters are interested in
 - fast, first-guess algorithms run on most events
 - loose “quality cuts” throw away the junk
- PnF then farms the events out to a computer cluster at pole

Filter Examples (not exhaustive!)

- Muon filter
 - hit cleaning -> calibration -> pulse extraction -> fast track reconstruction -> direction-dependent quality cuts
- Cascade filter
 - events that look more blob-like than track-like (tensor of inertia ratio)
- EHE filter
 - high-energy events (total NPE)
- Sun & Moon filter
 - events coming from current Sun and Moon position (WIMPs, moon shadow)
- IceTop filter
 - quality air shower events (also: in-ice coincidences)
- quite a few others for specific analyses

Muon Filter Passing Rate (simulation)

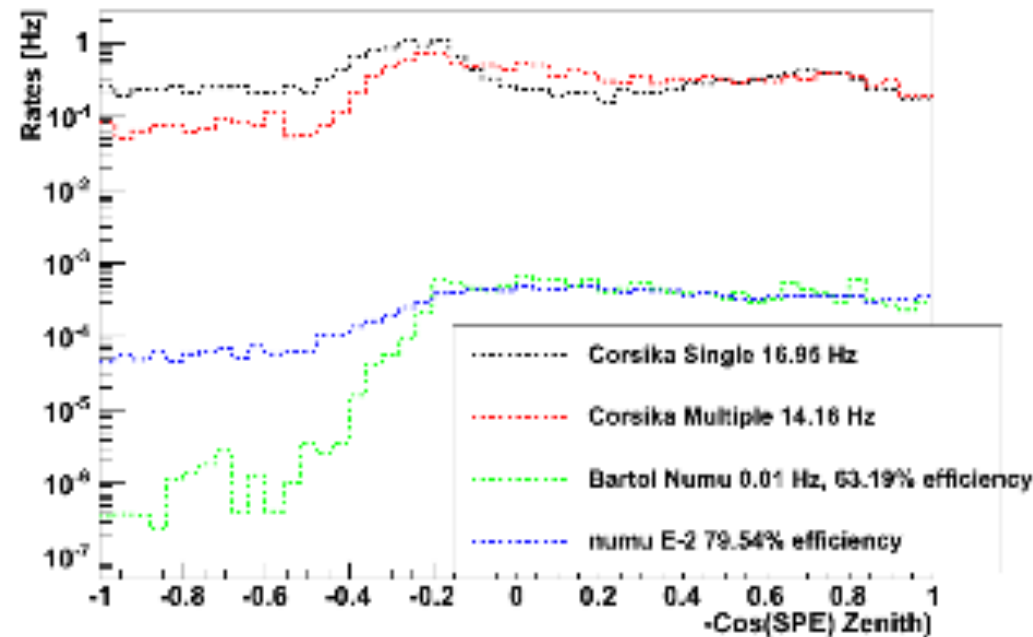

Real-time Alert System

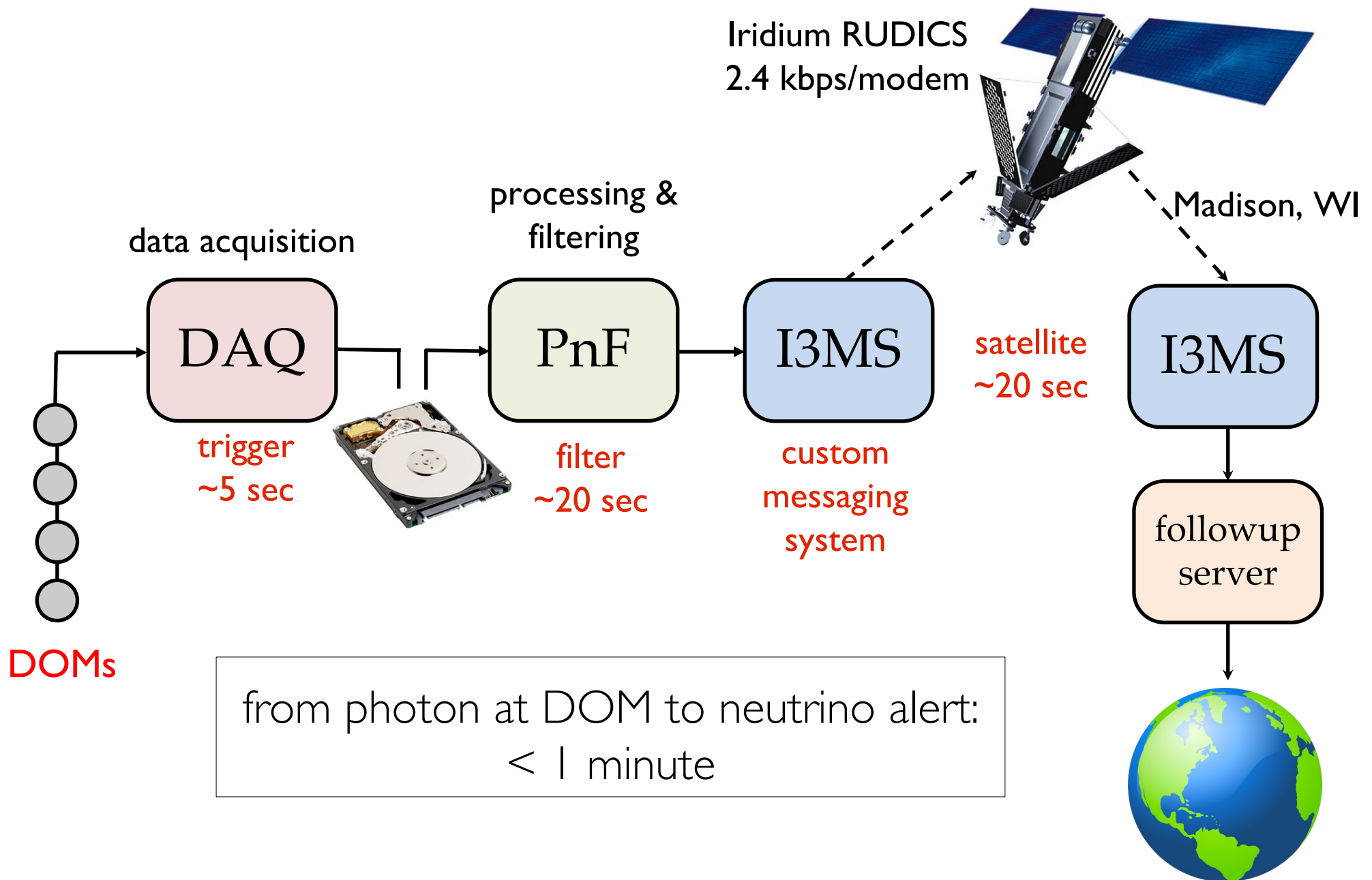

SuperDST / WaveDeform

- Basic idea: send highly compressed version of almost every triggered event
 - send reconstructed pulses, not raw waveforms
 - unfold based on template SPE waveforms
- Deployed large-scale in 2012; unfolding is called WaveDeform

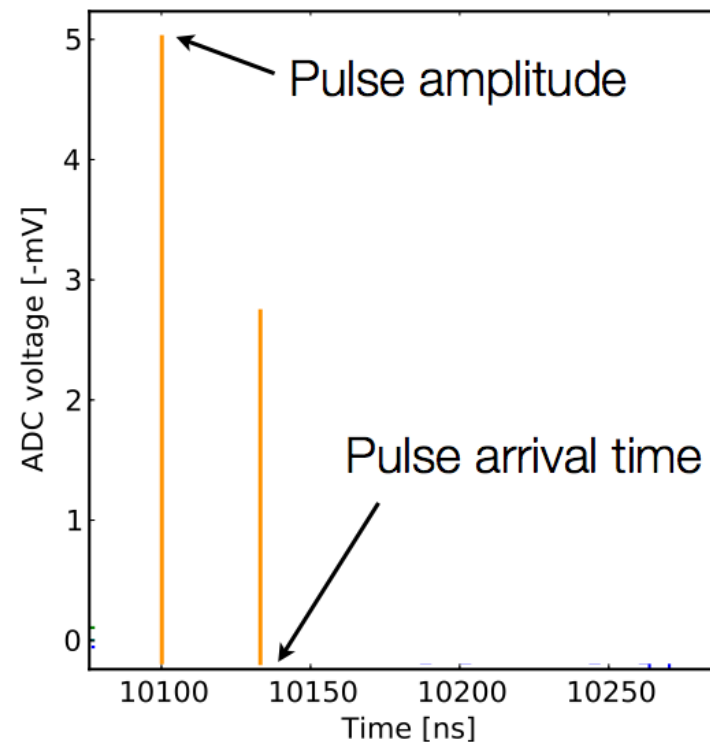
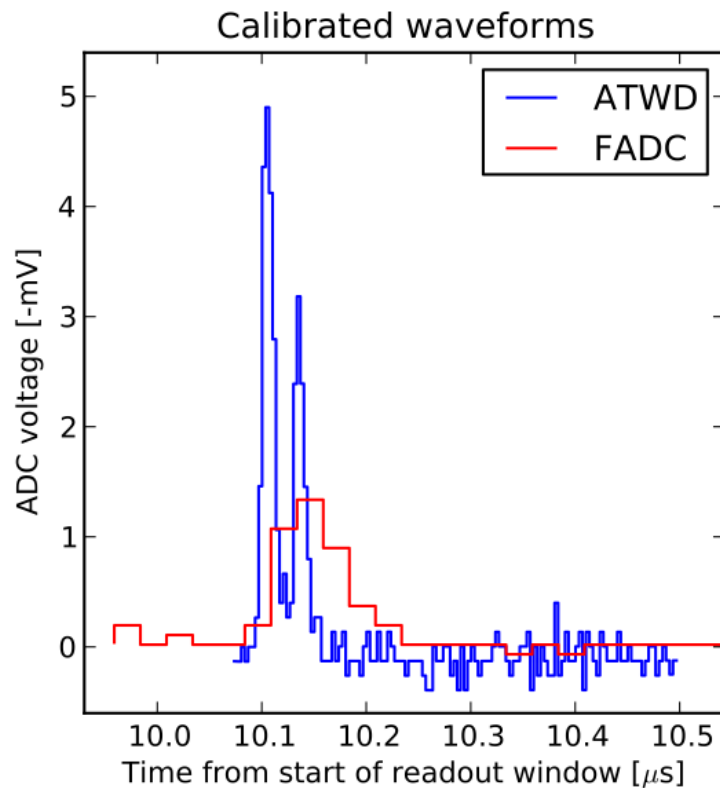

all you need for
many events!

SuperDST reconstructed waveforms

Raw payload: **4394 bytes**

SuperDST: **414 bytes**

Raw waveforms (“seatbelts”)
are still sent for

- multichannel hits
- events where the unfolding is bad
- high charge

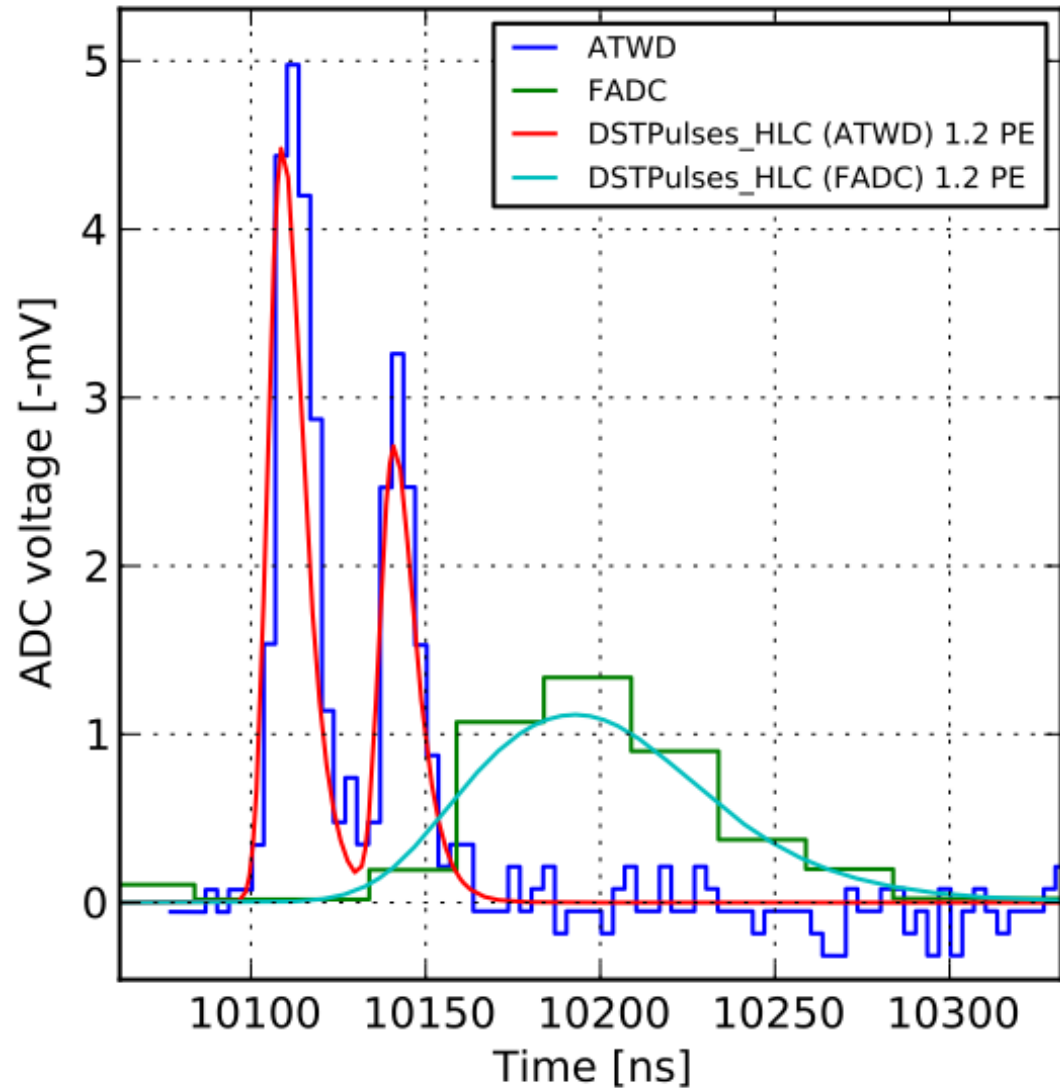

The IceCube Upgrade

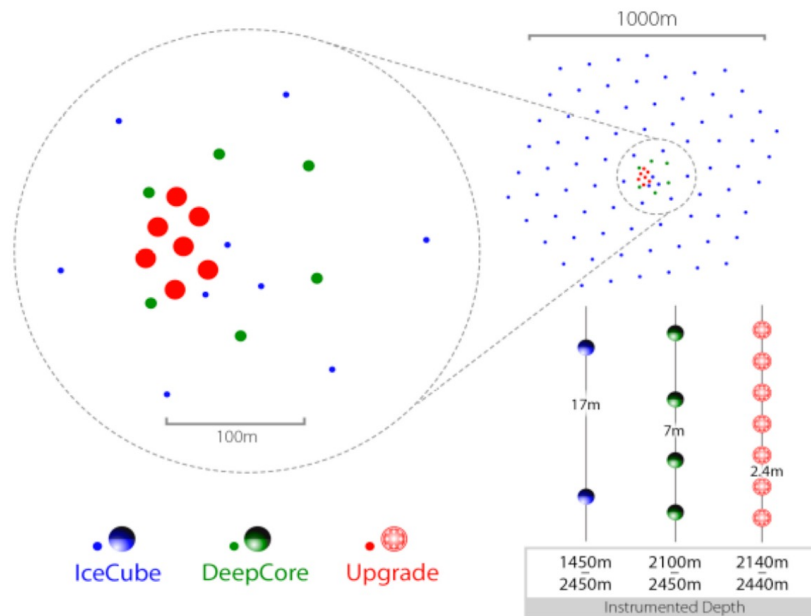
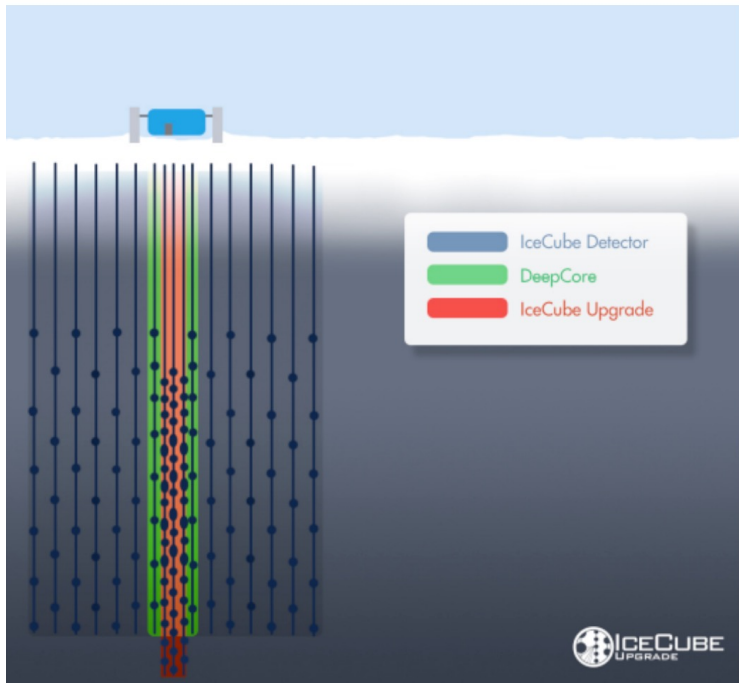

mDOM



D-Egg

- Seven new strings to be deployed with new DOMs and calibration instrumentation
- DOMs have more PMTs to increase photosensitive area
- New electronics but fundamentally the same design principles

For real-time detector status:

<http://live.icecube.wisc.edu>

Some sources for more information

- Previous years' boot camp presentations
<http://wiki.icecube.wisc.edu/index.php/Bootcamp>
- IceCube PMT Paper
<https://docushare.icecube.wisc.edu/dsweb/Get/Document-53922/>
- IceCube DOM-DAQ Paper
“The IceCube Data Acquisition Subsystem: Signal Capture, Digitization, and Time-Stamping”
[Nuclear Instruments and Methods in Physics Research A 601 \(2009\) 294–316](#)
<https://docushare.icecube.wisc.edu/dsweb/Get/Document-48249/>
- IceCube Detector Paper
“The IceCube Neutrino Observatory: instrumentation and online systems”
Journal of Instrumentation **12** (2017) P03012
<https://arxiv.org/pdf/1612.05093.pdf>
- Wiki page for LED flashers
<http://wiki.icecube.wisc.edu/index.php/Flashers>
- Docushare areas and personal websites
Docushare: <https://docushare.icecube.wisc.edu/dsweb/View/Collection-410>
Jerry Przybylski: http://icecube.lbl.gov/~gtp/site_map.html#ForIceCube
Thorsten Stezelberger: <http://glacier.lbl.gov/~thorsten/ATWD/>
Nobuyoshi Kitamura: <http://icecube.wisc.edu/~kitamura/>
- N.B. many more details being taken care of like “toroid droop”, baseline offsets, channel non-matching, PMT saturation, afterpulses, more precise optical sensitivity measurement, ...

Some sources for more information

- I3Live documentation:
<https://live.icecube.wisc.edu/doc/main/>
- TFT proposals:
http://wiki.icecube.wisc.edu/index.php/Trigger_Filter_Transmission_Board
- SuperDST:
<http://software.icecube.wisc.edu/documentation/projects/dataclasses/superdst.html>
<http://wiki.icecube.wisc.edu/index.php/SuperDST>
<https://events.icecube.wisc.edu/indico/contributionDisplay.py?contribId=140&sessionId=4&confId=33>
- Supernova DAQ:
<http://wiki.icecube.wisc.edu/index.php/Supernova>
- Monitoring:
<http://wiki.icecube.wisc.edu/index.php/Monitoring>
- Problem DOMs:
https://live.icecube.wisc.edu/dom_problems/
http://wiki.icecube.wisc.edu/index.php/Problem_DOMs (historical)

Extra Slides

Why so many channels and digitizers?

- Fast digitizers are power hungry, and the ATWD design was the alternative
 - When triggered, the ATWD quickly stores 128 samples of waveform, then digitizes these
 - During the digitization period, the ATWD is disabled, so a second one is provided to avoid losing additional hits (“ping-pong”)
- The FADC is a slower digitizer to cover the case of longer waveforms
- Each channel had only 10 bit resolution so could not accommodate the dynamic range from small signals to large signals... thus needed ch.0/1/2
- But we pay a price in complexity and some funky problems when combining information from different gain channels

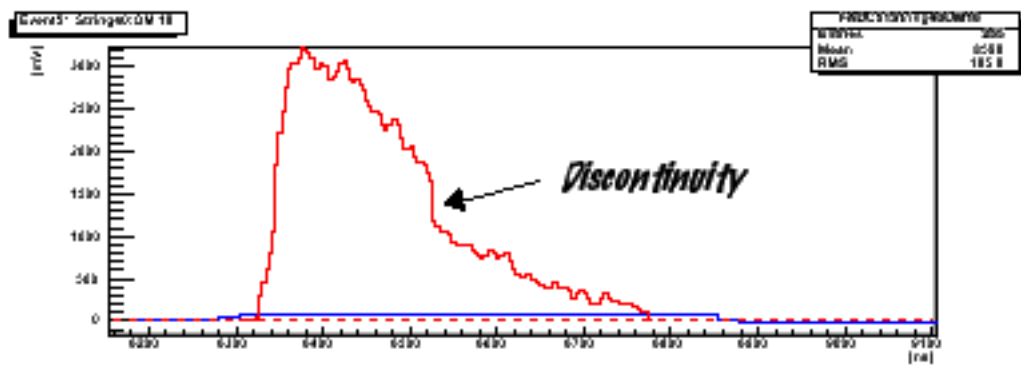

ATWD peculiarities

- Each ATWD has a “fingerprint” or pedestal pattern which must be subtracted from the waveform (happens automatically in the software)

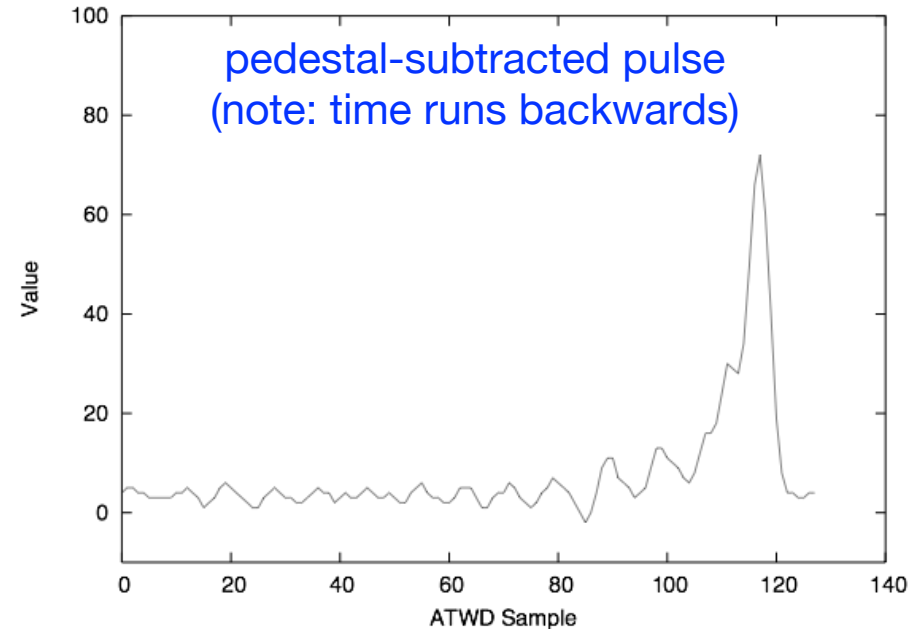
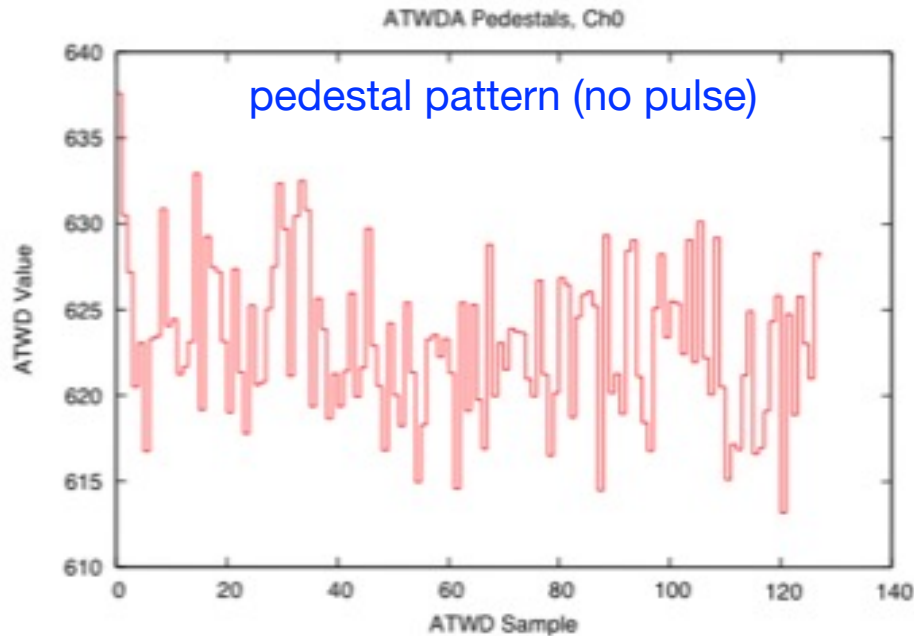

- Baseline voltage is very sensitive to DOM conditions; baselines are measured from previous runs and subtracted before pulses analyzed
- ATWD documentation:
http://docushare.icecube.wisc.edu/docushare/dsweb/Get/Document-21613/atwd_manual.pdf
<http://glacier.lbl.gov/~thorsten/ATWD/>

Trigger Types

- **Simple Multiplicity Trigger (SMT)**
 - N HLC hits or more in a time window
 - Example: InIce SMT8 with $N_{\text{hits}} \geq 8$ in $5 \mu\text{s}$
 - readout window around this captures early and late hits ($-4 \mu\text{s}$, $+6 \mu\text{s}$)
- **String** trigger (a.k.a. Cluster trigger in DAQ-land)
 - N HLC hits out of M DOMs on a string in a time window
 - Example: 5 hits from a run of 7 adjacent DOMs in a time window of 1500 ns
- **Volume** trigger (a.k.a Cylinder trigger in DAQ-land)
 - simple majority of HLC hits (SMT4) with volume element including one layer of strings around a center string
 - cylinder height is 5 DOM-layers (2 up and down from the selected DOM).
- **Slow Particle** trigger (SLOP)
 - slow-moving hits along a track
 - lengths of the order of $500\mu\text{s}$ and extending up to milliseconds
- **Fixed Rate** trigger, **Minimum Bias** trigger, **Calibration** trigger

SLOP Trigger

- Consider pairs of hits with LC condition
- Remove pairs if too close in time (T_{prox})
- Form 3-tuples of pairs within time window (T_{min}, T_{max})
- Track-like check on 3-tuples:
 - minimum inner angle α_{min}
 - normalized velocity difference v_{rel}
- Condition on minimum number of 3-tuples

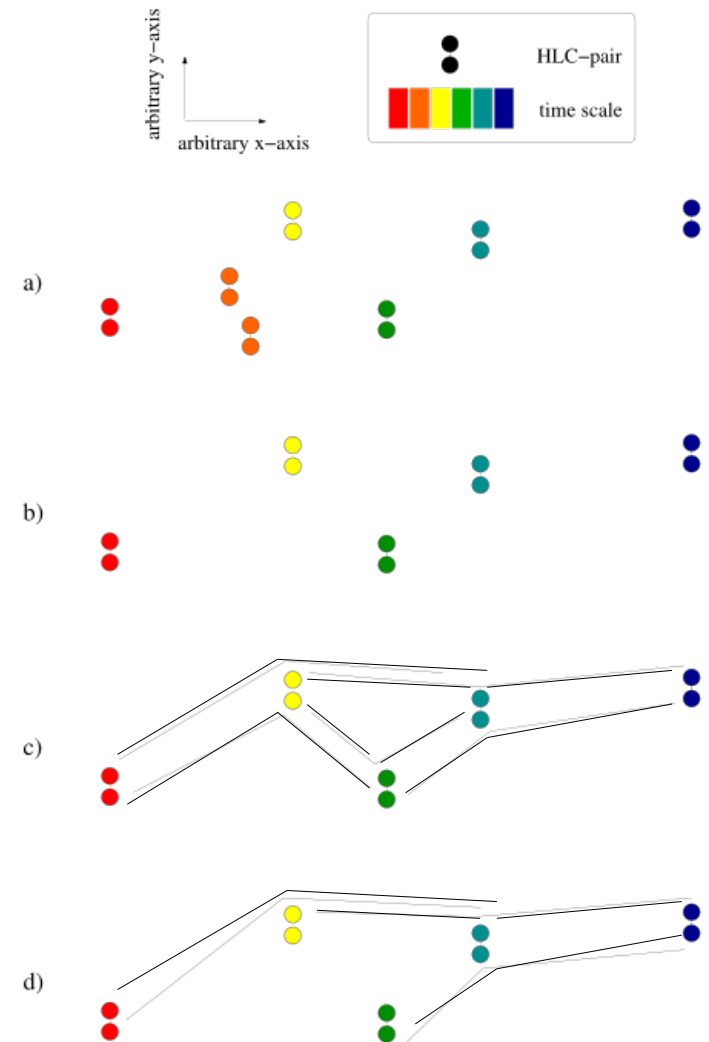

Trigger	N_{tuple}	T_{prox} (μs)	T_{min}, T_{max} (μs)	α_{min}	v_{rel}	Rate (Hz)
SLOP	5	2.5	[0, 500]	140°	0.5	12

Topological Triggers

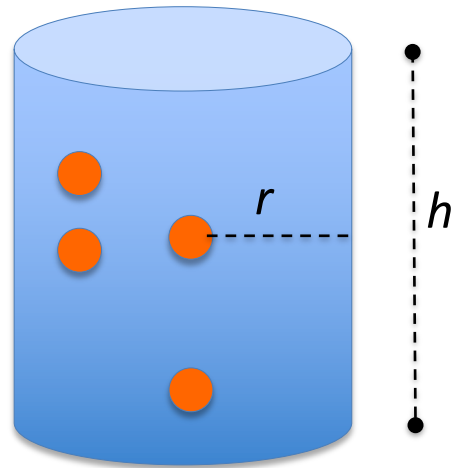

Volume trigger: N hits within a cylindrical volume around DOM in a time window



String trigger: N hits of M DOMs on a string in a time window

Trigger	HLC hits	Topology	Window (μs)	Rate (Hz)
Volume	4	cylinder $r=175\text{m}$, $h=75\text{m}$	1	3700
String	5	of 7 DOMs on string	1.5	2200

Specialized trigger: monopoles

T. Glüsenkamp

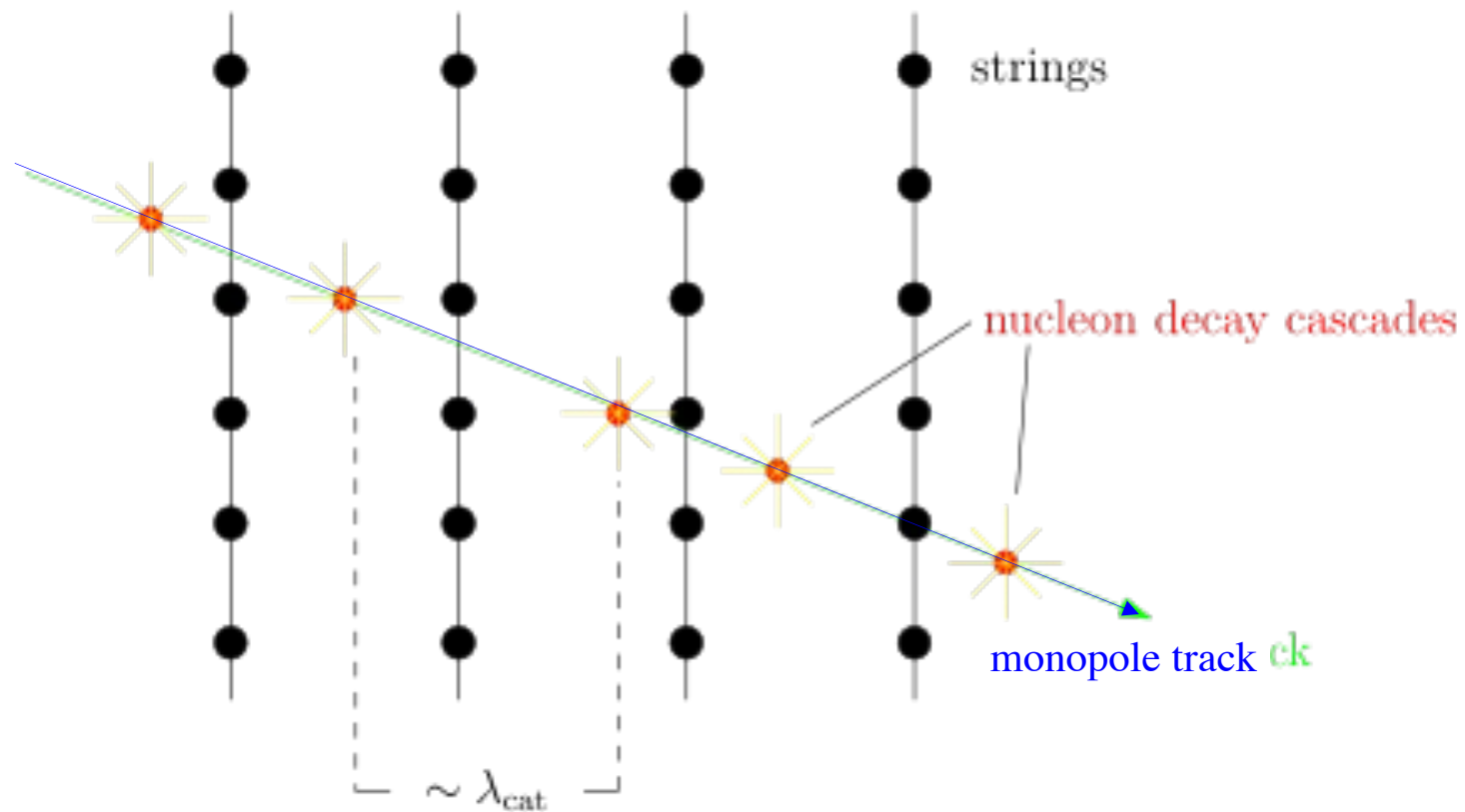

Signature of some exotic particles (magnetic monopoles, Q-balls, etc.):
slow ($v \sim 0.001-0.01c$) tracks with intermittent cascades

Slow particle speed means a longer trigger window is needed!

Trigger Readout

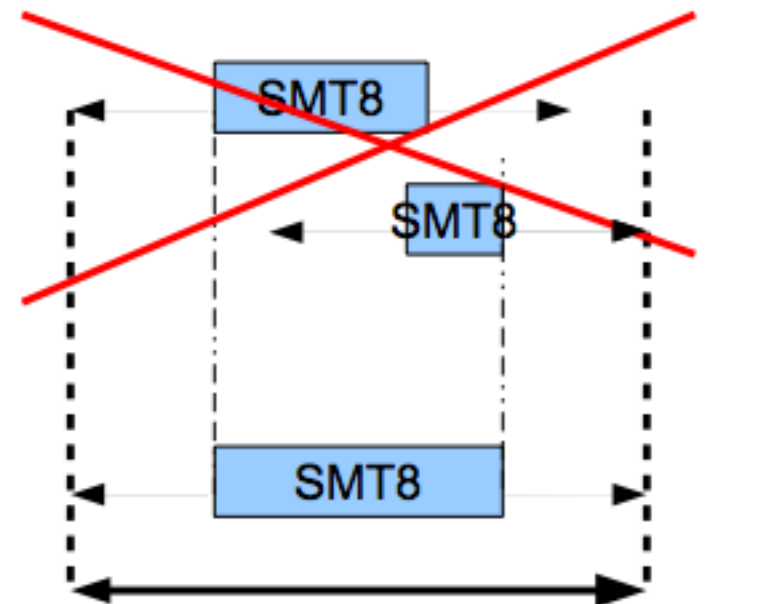
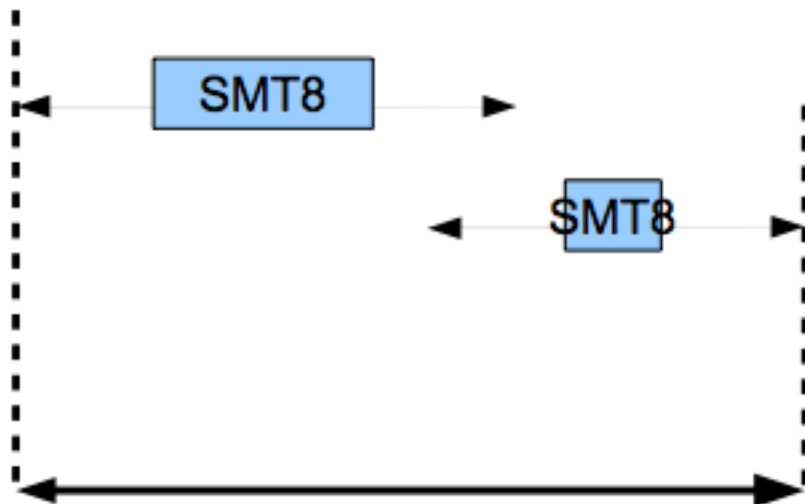
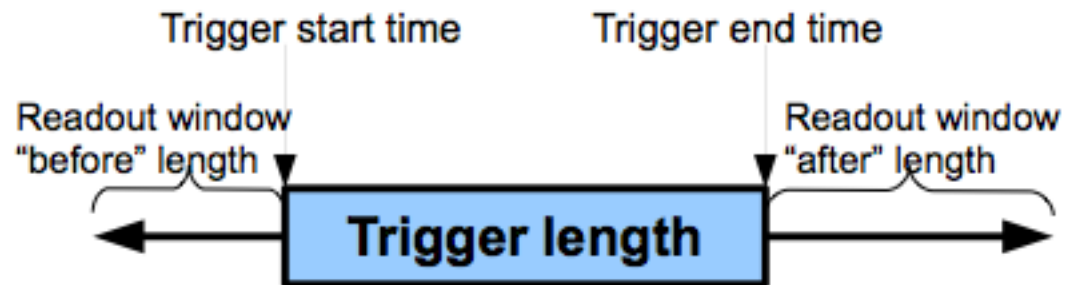

Trigger rate example

Trigger	Rate (Hz)
InIce SMT8	2113
DeepCore SMT3	256
SLOP	13.3
FRT	0.0333
String	2240
Volume	3727
MinBias	59.4

Event rate from Run 120029: 2742 Hz

Processing and Filtering (PnF)

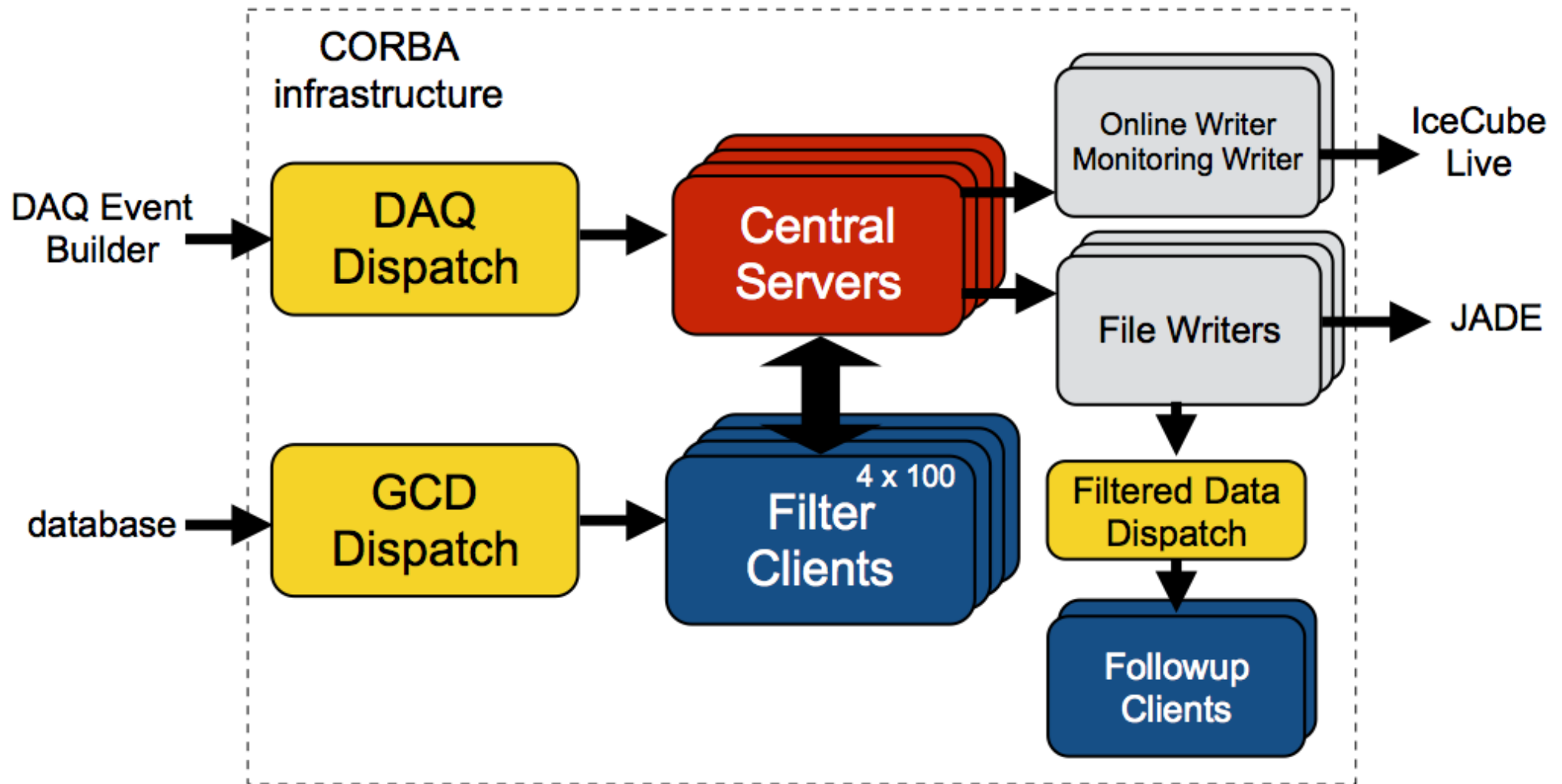

Triggering, Filtering, and Transmission Board

- How to balance needs of everyone wanting:
 - special DAQ trigger
 - special physics event filter
 - lots of satellite bandwidth
- TFT board reviews proposals once a year
 - changes are made at the “physics run start”, typically in May
- Wiki is a good place to start for trigger / filter descriptions

http://wiki.icecube.wisc.edu/index.php/Trigger_Filter_Transmission_Board

2023 Physics Run Filtering Scheme

- Working towards a major revision of the filtering scheme and L2 processing for the 2023 physics run start (~May 2023)
- Satellite L1 data becomes "superDST for all events"
 - first-level filters can be modernized
 - more flexible since running in the North
- PnF still supports realtime filters
- Satellite options are expanding
 - 2022–23 pole season: Starlink @ IceCube Lab?

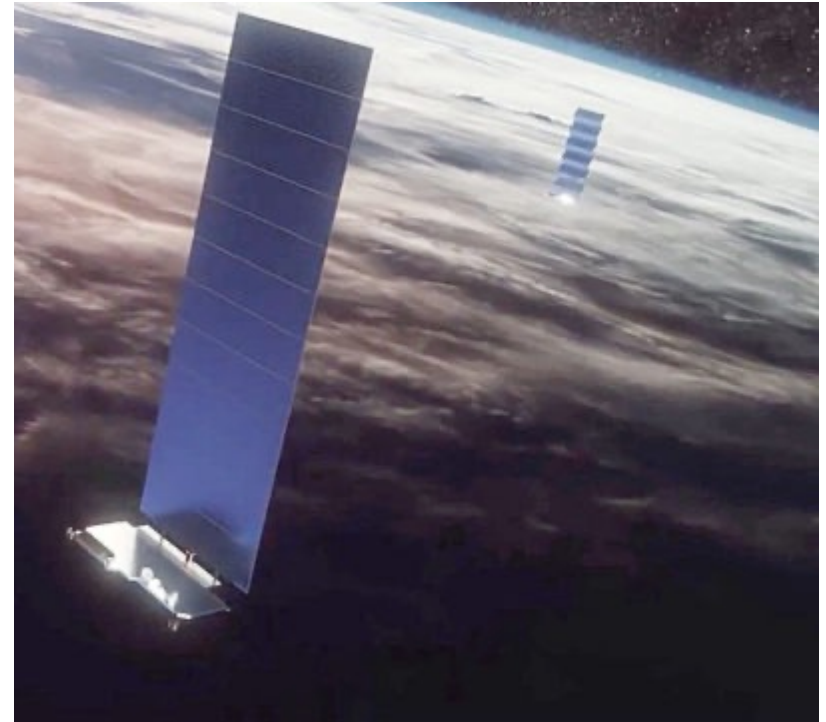

SpaceX Starlink satellites

Experiment Control and I3Live

